

PARTS DIAGRAM & PARTS LIST

ULTREX

80/112 LBS THRUST - 24/36 VOLT - 45"/52"/60" SHAFT

The parts diagram and parts list provides Minn Kota® WEEE compliance disassembly instructions. For more information about where you should dispose of your waste equipment for recycling and recovery and/or your European Union member state requirements, please contact your dealer or distributor from which your product was purchased. Tools required, but not limited to: flat head screwdriver, Phillips screwdriver, socket set, pliers, wire cutters.

ULTREX MOTOR

Motor Parts Diagram

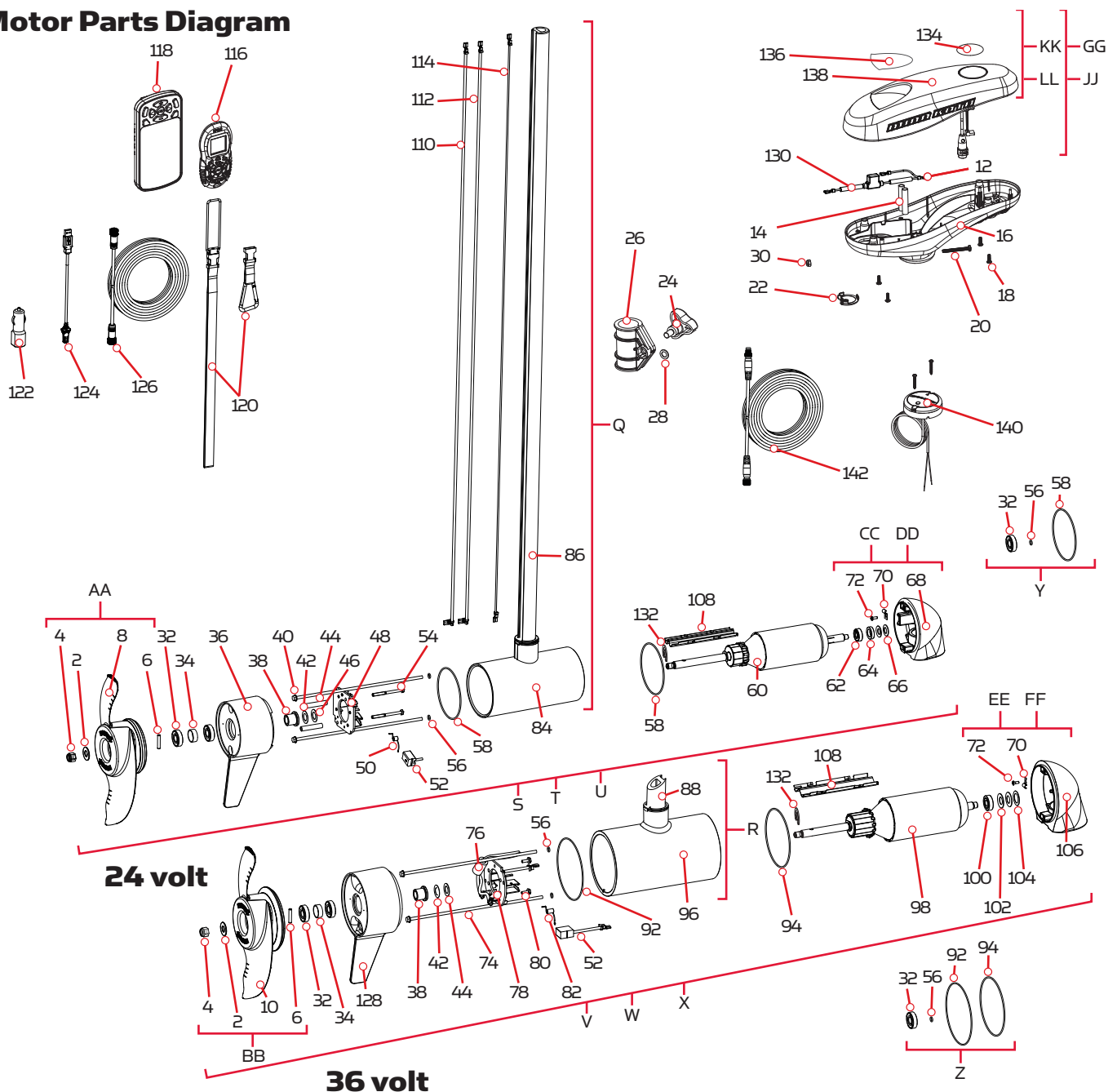

PARTS DIAGRAM & PARTS LIST

Motor Parts List

Assembly	Part #	Description	Quantity
Q	2777095	CTR HSG ASY, CB 80#, FW 60" TUBE	1
R	2777243	CTR HSG ASY, CB 112#, FW, 60" TUBE	1
S	2777005	80#/45" 24V MOTOR US2 *MOTOR & TUBE*	1
T	2777003	80#/52" 24V MOTOR US2 *MOTOR & TUBE*	1
U	2777017	MTR/TUBE ASSY 80# 60" UTX/US2 *MOTOR & TUBE*	1
V	2777089	MTR/TUBE ASSY 112# 45" UTX/US2 *MOTOR & TUBE*	1
W	2777080	MTR/TUBE ASY 112# 52" TRRV/US2 *MOTOR & TUBE*	1
X	2777088	MTR/TUBE ASY 112# 60" UTX/US2 *MOTOR & TUBE*	1
Y	2889460	80# THRUST SEAL KIT	1
Z	2881450	112# THRUST SEAL KIT	1
AA	1378132	80# THRUST PROP KIT	1
BB	1378160	112# THRUST PROP KIT	1
CC	9421-287	PLN END HSG/TRANSDUCER ASY 4.0 45"	1
DD	9421-290	PLN END HSG/TRANSDUCER ASY 4.0 52"/60"	1
EE	9421-244	PLN END HSG/TRANSDUCER ASY 4.5 45"	1
FF	9421-246	PLN END HSG/TRANSDUCER ASY 4.5 52"/60"	1
GG	2774062 ♦	MOTOR KIT IPLT 1.6 TRV, ULTREX *I-PILOT RECEIVER*	1
JJ	2774064 ♦	MOTOR KIT, IPLT 3.0 TRV, ULTREX *I-PILOT LINK RECEIVER*	1
KK	2770204 ♦	COVER KIT, IPLT 1.6 TRV, ULTREX *I-PILOT COVER & DECALS ONLY*	1
LL	2770211 ♦	COVER KIT, IPLT 3.0 TRV, ULTREX *I-PILOT LINK COVER & DECALS ONLY*	1
Item	Part #	Description	Quantity
2	2091701	WASHER-PROP (LARGE)	1
4	2093101	NUT-PROP,NYLOC,LG,MX101 3/8 SS	1
6	2262658	PIN-DRIVE 1" X 3/16" S/S	1
8	2331160	PROP-WW2 (4") W/ADP.RING	1
10	2341160	PROP-WW2(4.5)W/ADP.RING	1
12	2218200	FUSE HOLDER ASSEMBLY	1
14	2065400	WIRE INSULATOR-LGE 1-3/4, BLUE	2
16	2292500	CONTROL BOX, ULTREX, T2	1
18	2372100	SCREW-#8-18 X 5/8 THD* SS	22
20	2093400	SCREW-#10-24 x 1-7/8 PPH SS	1
22	2224700	INSERT-PLUG	1
24	2260905	KNOB-SOFT GRIP,HG/DR,ZNC	1
26	2291500	DEPTH COLLAR 1.3 X 3.0	1
28	2321702	WASHER-FLAT, .375 NYLON	1
30	2333101	NUT-HEX #10-24 UNC-2B NYL SS	1

✘ This part is included in an assembly and cannot be ordered individually.

▲ Not shown on Parts Diagram.

♦ May only be available with i-Pilot or i-Pilot Link.

PARTS DIAGRAM & PARTS LIST

Item	Part #	Description	Quantity
32	880-025	SEAL	2
34	725-095	PAPER TUBE, SEAL	1
36	92-300-170	BRUSH END HSG, 80#	1
38	144-017	BEARING, FLANGE	1
40	830-095	THRU BOLT 12-24	2
42	990-052	WASHER, NYLATRON	1
44	990-051	WASHER-STEEL THRUST	1
46	973-025	SPACER, BRUSHPLATE	2
48	9-738-015	BRUSH PLATE ASSY, 4"	1
50	975-041	SPRING-TORSION	2
52	186-094	BRUSH 4"	2
	188-095	BRUSH, 4.5"	2
54	830-027	SCREW-BRUSH PLATE 10-32	2
56	701-009	O-RING, THRU BOLTS	2
58	701-043	O-RING, END HOUSINGS	2
60	2-100-214	ARMATURE ASSY	1
62	140-010	BEARING - BALL	1
64	990-045	SPACER, THRUST	1
66	992-010	WASHER, SPRING BELLEVILLE	2
68	✘	PLN END HSG-PNTD-4" US2.5 CB	1
70	230-038	CABLE CLAMP, STEEL	1
72	2302104	SCREW-#6 X 3/8	1
74	830-094	THRU BOLT 12-24	2
76	2307312	BEAD-FERRITE	1
78	9-738-011	BRUSH PLATE ASSY, 4.5"	1
80	2053410	SCREW-BRUSH PLATE, 10-32	2
82	975-045	SPRING-TORSION	2
84	✘	CTR HSG ASY 4.0" FW MGNTZ	1
86	✘	TUBE-COMP, BLK, 45", W 1/4" WALL 80#	1
	✘	TUBE-CMP, BLK 60" 1/4" WALL 80#	1
88	✘	TUBE-COMP, BLK, 45", W 1/4" WALL 112#	1
	✘	TUBE-CMP, BLK 60" 1/4" WALL 112#	1
92	701-103	O-RING, 103 MM X 3 MM	1
94	701-098	O-RING, 98MM X 2MM	1
96	✘	CTR HSG ASY 4.5" MAG FW CB TER	1
98	2-100-245	ARMATURE ASSY	1
100	140-014	BEARING - BALL	1

✘ This part is included in an assembly and cannot be ordered individually.

▲ Not shown on Parts Diagram.

◆ May only be available with i-Pilot or i-Pilot Link.

PARTS DIAGRAM & PARTS LIST

Item	Part #	Description	Quantity
102	992-011	WASHER, SPRING BELLEVILLE	2
104	990-011	WASHER, SHIM	1
106	✘	PLN END HSG 4.5" US2.5 PNT FW	1
108	582-013	CLIP, RETAINING SHORT	1
110	640-117	MOTOR WIRE, RED, 80#, 45"	1
	640-132	MOTOR WIRE, RED, 80#, 52"	1
	640-138	MOTOR WIRE, RED, 80#, 60"	1
	640-140	MOTOR WIRE, RED, 112#, 45"	1
	640-142	MOTOR WIRE, RED, 112#, 52"	1
	640-139	MOTOR WIRE, RED, 112#, 60"	1
112	640-013	MOTOR WIRE, BLACK, 80#, 45"	1
	640-017	MOTOR WIRE, BLACK, 80#, 52"	1
	640-038	MOTOR WIRE, BLACK, 80#, 60"	1
	640-040	MOTOR WIRE, BLACK, 112#, 45"	1
	640-042	MOTOR WIRE, BLACK, 112#, 52"	1
	640-039	MOTOR WIRE, BLACK, 112#, 60"	1
114	640-315	BONDING WIRE, BROWN, US2.0, 45"	1
	640-316	BONDING WIRE, BROWN, US2.0, 60"	1
116	2994075 ♦	REMOTE ASSY, IPILOT 1.6	1
118	2994076 ♦	REMOTE ASSY, IPILOT LINK *LINK ONLY*	1
120	2390800	LANYARD, REMOTE W/ CARABEENER	1
122	2375901 ♦	ADAPTER, USB DC POWER *LINK ONLY*	1
124	2373241 ♦	CABLE, USB REMOTE CHARGER *LINK ONLY*	1
126	490389-1 ♦	CABLE, ETHERNET, 30' * LINK ONLY*	1
128	92-300-155	BRUSH END HSG, 112#	1
130	2375400	SHRINK TUBE-1/4 OD X 1-3/4	2
132	788-040	RETAINING RING	1
134	✘	DECAL, DOMED IPILOT FW	1
	✘	DECAL, DOMED IPILOT LINK FW	1
136	✘	DECAL - GENERIC, PUSH BTN TOP FW	1
138	✘	CVR, CTRL BX IP, UTX	1
140	2996400	HEADING SENSOR ASSEMBLY	1
142	2211415	CABLE-EXTENSION, PD/AP 110"	1

✘ This part is included in an assembly and cannot be ordered individually.

▲ Not shown on Parts Diagram.

♦ May only be available with i-Pilot or i-Pilot Link.

ULTREX STEERING MODULE

Steering Module Parts Diagram

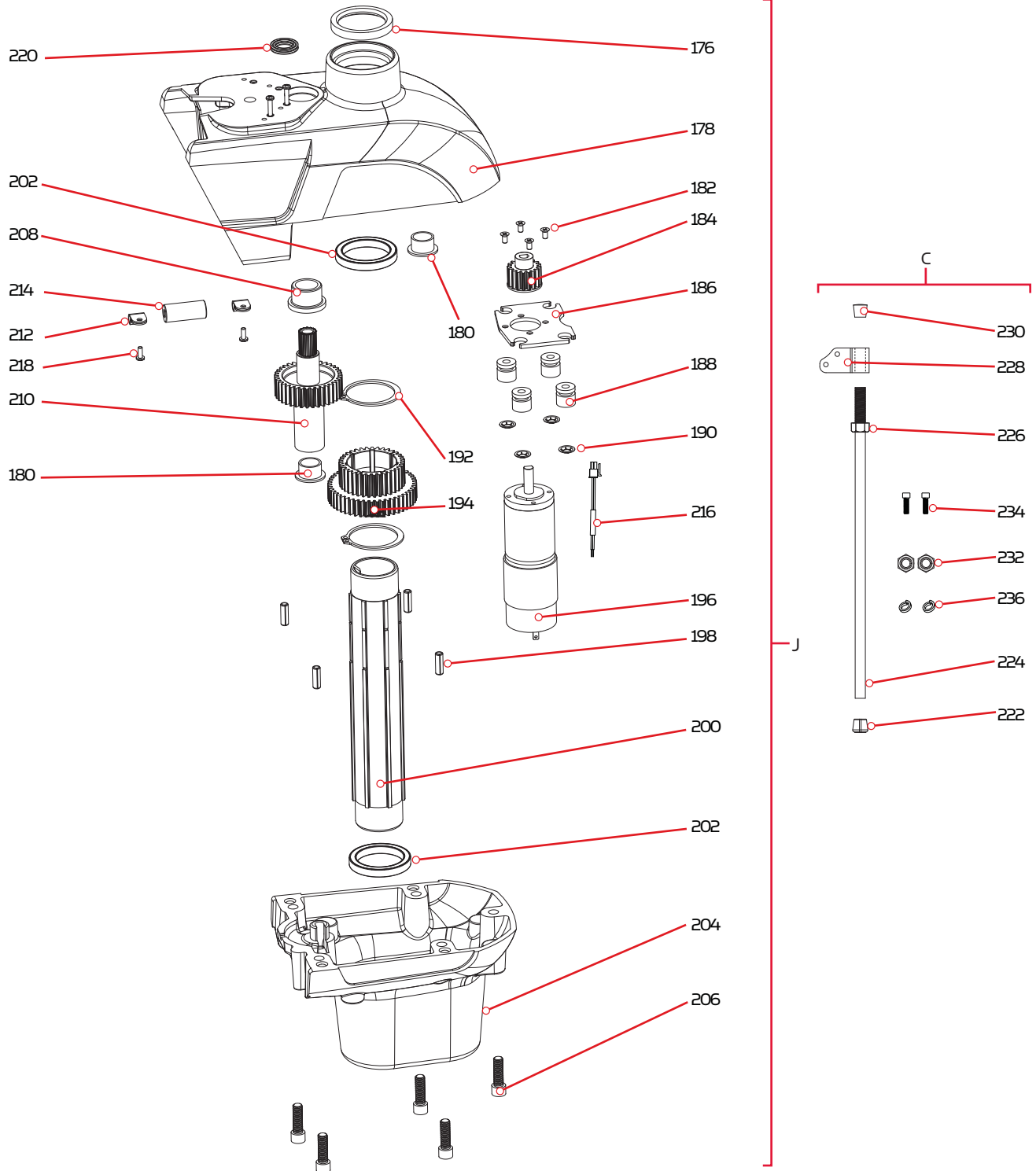

PARTS DIAGRAM & PARTS LIST

Steering Module Parts List

Assembly	Part #	Description	Quantity
J	2991896	STEERING MODULE ASSEMBLY FW	
C	2991925	BRACKET STABLZR ARM ASY	1
Item	Part #	Description	Quantity
176	✘	SEAL	1
178	✘	HOUSING, UPPER, PAINTED	1
180	✘	BUSHING-1012-08	2
182	✘	SCREW-M4 X 8MM, FHP, SS	4
184	✘	GEAR-MOTOR	1
186	✘	PLATE, MOTOR	1
188	✘	BUSHING, DAMPENING	4
190	✘	NUT-PUSH, 1/4" ZP	4
192	✘	RETAINING RING, 1 3/4" SHAFT	2
194	✘	GEAR-CLUSTER, 35-48T	1
196	✘	MOTOR-DRIVE	1
198	✘	PIN-SPRING, 1/4 X 3/4, ZP	4
200	✘	TUBE-STEER, MACHINED	1
202	✘	BEARING	2
204	✘	HOUSING, LOWER, PAINTED	1
206	✘	SCREW-5/16-18 X 1" SHCS ZP	5
208	✘	BUSHING-1216-12	1
210	✘	GEAR, CABLE	1
212	✘	CABLE CLAMP, 3/16", NYLON	2
214	✘	BEAD-FERRITE	1
216	✘	WIRE HARNESS, MOTOR,SHORT	1
218	✘	SCREW-#6-20 X 3/8 THD*(SS)	2
220	✘	SEAL, QUAD RING, 3/4"	1
222	2265100	BUMPER STABILIZER	1
224	2263624	STABILIZER ROD	1
226	2263107	NYLON HEX NUT 3/4 - 10 UNC	1
228	2281829	BRACKET	1
230	2260221	VINYL CAP	1
232	2223100	NUT 5/16-18 NYLOCS SS	2
234	2263422	BOLT 5/16-18 X 1" SS	2
236	2281700	5/16 "ID X .457 OD HIGH COLLAR LOCK WASHER	2

✘ This part is included in an assembly and cannot be ordered individually.

▲ Not shown on Parts Diagram.

◆ May only be available with i-Pilot or i-Pilot Link.

ULTREX FOOT PEDAL

Foot Pedal Parts Diagram

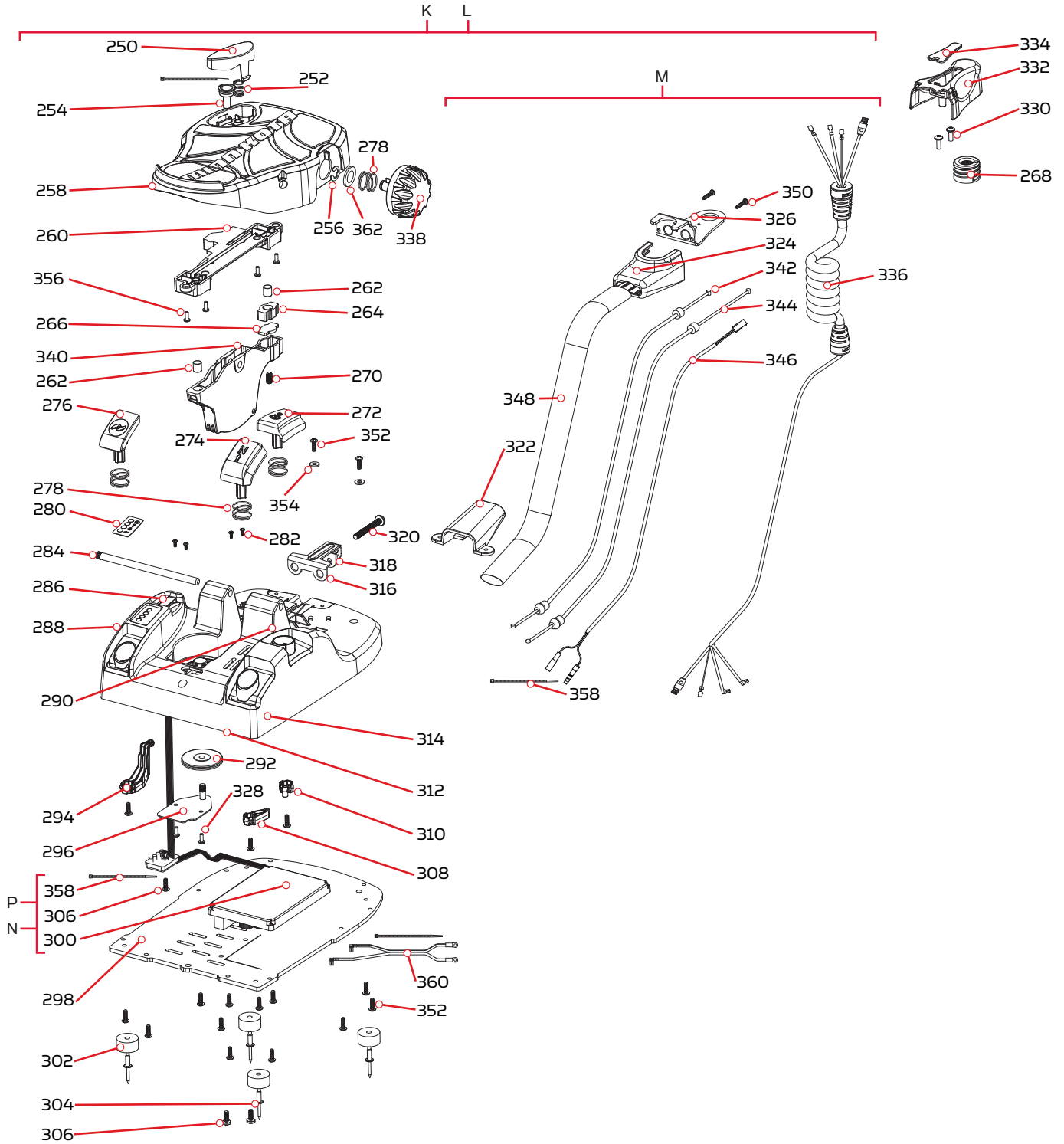

PARTS DIAGRAM & PARTS LIST

Foot Pedal Parts List

Assembly	Part #	Description	Quantity
K	2992155	36V FOOT PEDAL ASSEMBLY	1
L	2992150	24V FOOT PEDAL ASSEMBLY	1
M	2771200	FT PED CABLE, WIRE HARNESS, ASM	1
N	2774061	CONTROL BOARD KIT, 36V ULTREX	1
P	2774060	CONTROL BOARD KIT, 24V ULTREX	1
Item	Part #	Description	Quantity
250	2993705	PUSH BTTN/MAGNET ASSY	1
252	2302732	SPRING-LOWER PEDAL S/S	1
254	2260810	CLIP, REED SENSOR	1
256	2263000	E-RING TRU-ARC#5133-43	1
258	2994450	FOOT PEDAL W/MAGNET	1
260	✘	CONTROL BOARD,SENSOR BOARD	1
262	✘	ACTUATOR-SENSOR, DIA. .375 MAX	2
264	✘	CARRIER, ACTUATOR	1
266	✘	BACKER, CARRIER	1
268	2292300	PULLEY, CABLE DRUM	1
270	✘	SCREW-1/4-20 X 1/2 SET, 316 SS	1
272	2293720	BUTTON-SL, FOOT PEDAL	1
274	2293730	BUTTON-AP, FOOT PEDAL	1
276	2293710	BUTTON-PROP, FOOT PEDAL	1
278	2292700	SPRING, BUTTON, FOOT PEDAL	4
280	2295625	DECAL, INDICATOR LIGHTS	1
282	2373440	SCREW-#4-24 X 1/4 PHCR SS TY B	4
284	2260511	PIN-PIVOT A/T FT PDL	1
286	2044022	SWITCH-POWER, ON/OFF	1
288	2992150	FOOT PEDAL W/BASE ASM, 24V	1
290	2266413	TENSION SCREW PLATE FTPEDAL	1
292	2262301	PULLEY (FOOT PEDAL)	1
294	2993715	ARM-SENSOR, PROP W/MAGNET	1
296	2266401	COVER-PULLEY (STAMPING)	1
298	2291920	PLATE-BOTTOM	1
300	2294061	CONTROL BRD, 36V, ULTREX	1
	2294060	CONTROL BRD, 24V, ULTREX	1
302	2265126	BUMPER PAD, FOOT PEDAL	4
304	2378600	RIVET-POP,3/16 X 3/4 ALUM.SHNK	4

✘ This part is included in an assembly and cannot be ordered individually.

▲ Not shown on Parts Diagram.

◆ May only be available with i-Pilot or i-Pilot Link.

PARTS DIAGRAM & PARTS LIST

Item	Part #	Description	Quantity
306	2223455	SCREW-#10-32 X 1/2" ZP MACHINE	2
308	2993735	ARM-SENSOR, AP W/MAGNET	1
310	2993725	ARM-SENSOR, SL W/MAGNET	1
312	2994500	BASE W/PIN, FOOT PEDAL	1
314	2365107	INSULATING PAD(2.3 X 3.2)	1
316	2263210	BRACKET-CONDUIT ADJUSTMEN	1
318	2263140	KEEPER-NYLOCK	1
320	2263466	SCREW-1/4-20 X 2" PPH SS/REI	1
322	2265115	BOOT-FOOT PEDAL BASE	1
324	2296410	COVER, COIL CORD	1
326	2291910	BRACKET, CABLE ANCHOR	1
328	2373450	SCREW-#8-18 X 3/8" THRD.CUT SS	2
330	2323406	SCREW-#10-24 X .50 CRPH SS	2
332	2296400	COVER, WRAP DRUM	1
334	2296405	COVER, MOTOR CONNECTION	1
336	2291200	COIL CORD ASSEMBLY	1
338	2290100	KNOB-SPEED CONTROL	1
340	✘	LOWER-ROCKER, FOOT PEDAL	1
342	2267505	CABLE ASSY-RIGHT (5')	1
344	2267515	CABLE ASSY-LEFT (5')	1
346	2297411	WIRE HARNESS, MOTOR, LONG	1
348	2265430	CABLE JACKET (5') AT MODEL	1
350	3393450	SCREW-#6-19 X .75 PPH HI-LO	2
352	2372100	SCREW-#8-18 X 5/8 THD* (SS	18
354	2261714	WASHER-MAXXUM FT PDL 18/8 SS	2
356	2332103	SCREW-#6-20 X 3/8 THD*(SS)	4
▲	2052510	CABLE CLAMP, 3/16", NYLON	2
▲	2301310	SCREW-#8-18 X 1/2 (SS)	2
▲	2298800	LOOM-WIRE, 1/4 X 4"	1
358	2256300	TIE WRAP-5.5" BLACK	4
360	2290605	LEAD WIRE, FOOT PEDAL	1
362	3391722	WASHER, FLAT 7/16	1

✘ This part is included in an assembly and cannot be ordered individually.

▲ Not shown on Parts Diagram.

◆ May only be available with i-Pilot or i-Pilot Link.

PARTS DIAGRAM & PARTS LIST

ULTREX MOUNT

Mount Parts Diagram

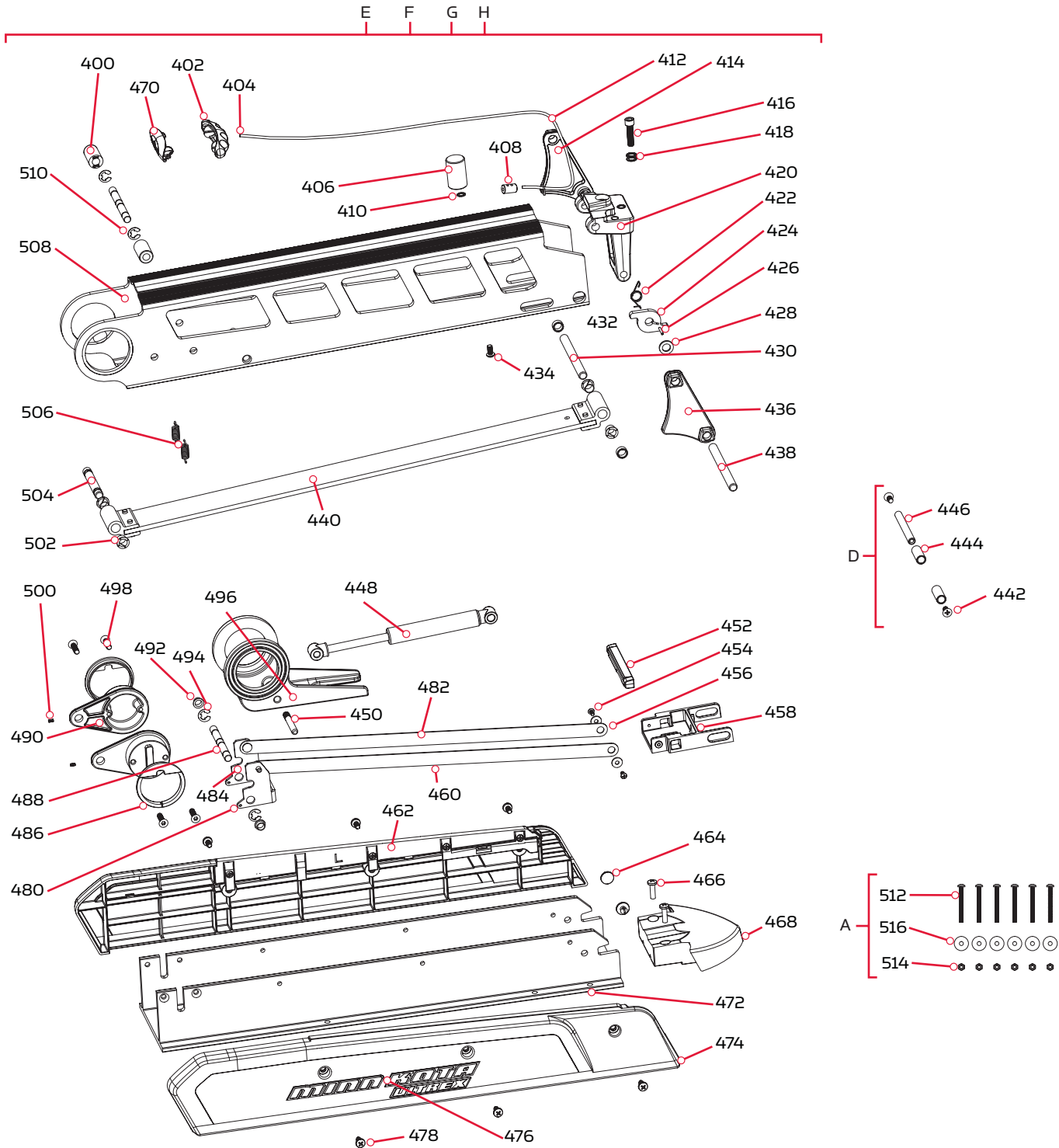

Mount Parts List

Assembly	Part #	Description	Quantity
E	2991733	MOUNT ASM ULTREX FW 112# 45"	1
F	2991734	MOUNT ASM ULTREX FW 80# 45"	1
G	2991735	MOUNT ASM ULTREX FW 80# 52/60"	1
H	2991736	MOUNT ASM ULTREX FW 112# 52/60"	1
D	2994912	BAG ASSY, FORTREX MOUNT HDW	1
A	2994887	INSTALLATION HARDWARE BAG ASSEMBLY	1
Item	Part #	Description	Quantity
400	2261505	SPACER, MOTOR REST	2
402	2280405	PULL GRIP, SOFT, BOTTOM	1
404	2291400	CABLE, PULL HANDLE, SS	1
406	2281516	SPACER, INNER ARM	1
408	2880800	PULL CABLE CLAMP & SCREW KIT	1
410	2281702	WASHER-LOCK, 1/4" EXTERNAL SS	1
412	2151700	WASHER-EYE SHAFT(.562 OD) SS	1
414	2280800	LINK,BOWGUARD MOUNT,LEFT	1
416	2293402	SCREW-5/16-18, SHCS, RIE, STEEL	1
418	2291700	WASHER-5/16, M8 WEDGE LOCK	1
420	2992333	ROPE GUIDE ASSEMBLY	1
422	2042711	SPRING-TORSION, SS 112# 45"	1
424	2283620	LATCH, SAFETY	1
426	2282611	PIN-SPRING, 3/32"	1
428	2281704	WASHER -7/16 NYLON	1
430	2282600	PIN 7/16" X 4.80" SS	1
432	2287303	BUSHING, UPPER PIN	2
434	2223418	SCREW-1/4-20X 1/2 SS BHCS	1
436	2280805	LINK, BOWGUARD MOUNT, RIGHT	1
438	2282608	PIN 7/16" X 5.15" SS	1
440	2993821	ASSY,INNER ARM,LONG,FW 80/112# 52/60"	1
	2993819	ASSY,INNER ARM,SHORT,FW 80/112# 45"	1
442	2283410	SCREW-1/4-20 X .500" PFH	2
444	2281710	SPACER, GAS SPRING, FORTREX	2
446	2282610	PIN, UPPER SHOCK	1
448	2288403	GAS SPRING (CYLINDER)	1
	2288404	GAS SPRING (CYLINDER) 80# 45" 52/60"	1
	2288405	GAS SPRING (CYLINDER) 112# 45"	1
450	2282604	PIN-KNURLED 5/16"X2 1/4"SS	1

✘ This part is included in an assembly and cannot be ordered individually.

▲ Not shown on Parts Diagram.

◆ May only be available with i-Pilot or i-Pilot Link.

PARTS DIAGRAM & PARTS LIST

Item	Part #	Description	Quantity
452	2283615	LATCH BAR	1
	2283616	LATCH BAR, STAINLESS STEEL *112 # 60" ONLY*	1
454	2373450	SCREW-#8-18 X 3/8" THRD.CUT SS	2
456	2261732	WASHER-#8, NYLON	3
458	2283610	BRACKET-LATCH/STRAP,ROPE PULL	1
460	2283601	LATCH STRAP, LONG MNT SS 80/112# 52/60"	2
	2283600	LATCH STRAP, SHORT MNT SS 80/112# 45"	2
462	2993915	SIDEPLATE ASSY, LONG, LEFT, FW 80/112# 52/60"	1
	2993910	SIDEPLATE ASSY, SHORT, LEFT, FW 80/112# 45"	1
464	2286700	PLUG-SPACER, BASE EXTRUSION	2
466	2073408	SCREW-1/4-20 X 7/8 PPH S/S	2
468	2283900	RAMP-MOTOR FW	1
470	2280400	PULL GRIP, SOFT, TOP	1
472	2281903	BASE EXTRUSION-SHORT, MACH. 80/ 112# 45"	1
	2281913	BASE EXTRUSION-LONG, MACH. 80/112# 52/60"	1
474	2993925	SIDEPLATE ASSY, LONG, RIGHT, FW 80/112# 52/60"	1
	2993920	SIDEPLATE ASSY, SHORT, RIGHT, FW80/112#045"	1
476	2295510	DECAL, SIDEPLATE, ULTREX	2
478	2323405	SCREW-1/4-20 X 1/2" MCH SS	6
480	2281922	BRACKET, LATCH	1
482	2288610	RIVET, SHLDR 5/16" X .159" SS	2
484	2280006	BEARING, NYLINER 5/16" (5L1-FF)	2
486	2287300	BUSHING-REAR PIVOT	2
488	2282602	PIN 3/8" X 3 3/4" SS	2
490	2281932	BRACKET-REAR PIVOT FW	2
492	2280008	BEARING-I GLIDE 3/8 SHAFT	2
494	2263011	E-RING 3/8 DIA. SHAFT	4
496	2281501	YOKE, FORTREX	1
498	2283411	SCREW-1/4-20X1.00 FHS RIE TORX	4
500	2283402	SCREW-SET 6/32 X .25" SS	2
502	2280005	BEARING, NYLINER 7/16" (7L7-F)	4
504	2282606	PIN-PIVOT, 7/16" X 3 1/8" SS	1
506	2282720	SPRING-EXTENSION SS	2
508	2284202	ARM-OUTER, SHORT, FW 80/112# 45"	1
	2284212	ARM-OUTER, LONG, FW 80/112# 52/60"	1
510	2263011	E-RING 3/8 DIA. SHAFT	2
512	2263468	1/4 - 20 X 2.5" SS PPH SCREW	6
514	2263103	1/4 - 20 SS NYLOCK NUT	6
516	2261713	1/4 FLAT 18-8 SS WASHER	6

✘ This part is included in an assembly and cannot be ordered individually.

▲ Not shown on Parts Diagram.

◆ May only be available with i-Pilot or i-Pilot Link.