

ENGINE MOUNT

TROLLING MOTORS

Owner's Manual

INTRODUCTION

THANK YOU

Thank you for choosing Minn Kota. We believe that you should spend more time fishing and less time positioning your boat. That's why we build the smartest, toughest, most intuitive trolling motors on the water. Every aspect of a Minn Kota trolling motor is thought out and rethought until it's good enough to bear our name. Countless hours of research and testing provide you the Minn Kota advantage that can truly take you "Anywhere. Anytime." We don't believe in shortcuts. We are Minn Kota. And we are never done helping you catch more fish.

REGISTRATION

Remember to keep your receipt and immediately register your trolling motor. A registration card is included with your motor or you can complete registration on our website at minnkotamotors.com.

SERIAL NUMBER

Your Minn Kota 11-character serial number is very important. It helps to determine the specific model and year of manufacture. When contacting Consumer Service or registering your product, you will need to know your product's serial number. We recommend that you write the serial number down so that you have it available for future reference.

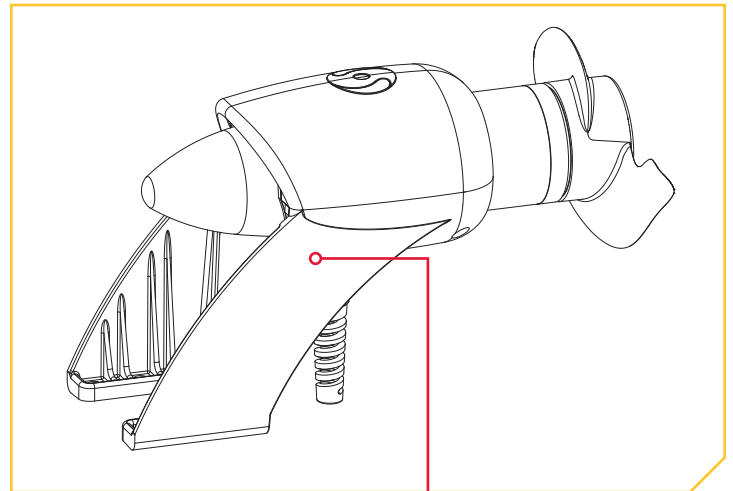

NOTICE: The serial number on your Engine Mount is located underneath the bracket.



MOTOR INFORMATION (For Consumer Reference Only)

Model Serial Number: _____

Controller Serial Number: _____

Purchase Date: _____

Store Where Purchased: _____

NOTICE: Do not return your Minn Kota product to your retailer. Your retailer is not authorized to repair or replace this unit. You may obtain service by: calling Minn Kota at (800) 227-6433; returning your product to the Minn Kota Factory Service Center; sending or taking your product to any Minn Kota authorized service center. A list of authorized service centers is available on our website, at minnkotamotors.com. Please include proof of purchase, serial number and purchase date for warranty service with any of the above options.

TABLE OF CONTENTS

SAFETY CONSIDERATIONS	4
WARRANTY	5
KNOW YOUR BOAT	6
FEATURES	7
INSTALLATION	8
Installing the Engine Mount	10
Installing the Control Module and Connecting it to the Motor	12
Installing the Hand Controller and Connecting it to the Control Module	14
BATTERY & WIRING INSTALLATION	15
Boat Rigging & Product Installation	15
Conductor Gauge and Circuit Breaker Sizing Table	15
Selecting the Correct Batteries	16
Additional Considerations	16
Connecting the Batteries	17
Connecting the Batteries in Series	17
WIRING DIAGRAM	19
USING AND ADJUSTING THE MOTOR	20
Motor Operation	20
Proper Operation	22
SERVICE & MAINTENANCE	23
Propeller Replacement	23
General Maintenance	24
Troubleshooting	24
For Further Troubleshooting And Repair	25
COMPLIANCE STATEMENTS	26
PARTS DIAGRAM & PARTS LIST	28
NOTES	31

SAFETY CONSIDERATIONS

Please thoroughly read the user manual. Follow all instructions and heed all safety considerations. Use of this product is only permitted for persons that have read and understood these instructions. Minors may use this product only under adult supervision.

WARNING

You are responsible for the safe and prudent operation of your vessel. We have designed your Minn Kota product to be an accurate and reliable tool that will enhance boat operation and improve your ability to catch fish. This product does not relieve you from the responsibility for safe operation of your boat. You must avoid hazards to navigation and always maintain a permanent watch so you can respond to situations as they develop. You must always be prepared to regain manual control of your boat. Learn to operate your Minn Kota product in an area free from hazards and obstacles.

WARNING

Never run the motor out of the water, as this may result in injuries from the rotating propeller. The motor should be disconnected from the power source when it is not in use or is off the water. When connecting the power-supply cables of the motor to the battery, ensure that they are not kinked or subject to chafe and route them in such a way that persons cannot trip over them. Before using the motor make sure that the insulation of the power cables is not damaged. Disregarding these safety precautions may result in electric shorts of battery(s) and/or motor. Always disconnect motor from battery(s) before cleaning or checking the propeller. Avoid submerging the Control Module and Hand Controller as water may enter. If the motor is used while water is present considerable damage can occur. This damage will not be covered by warranty.

WARNING

Take care that neither you nor other persons approach the turning propeller too closely, neither with body parts nor with objects. The motor is powerful and may endanger or injure you or others. While the motor is running watch out for persons swimming and for floating objects. Persons who lack the ability to run the motor or whose reactions are impaired by alcohol, drugs, medication, or other substances are not permitted to use this motor. This motor is not suitable for use in strong currents. The constant noise pressure level of the motor during use is less than 70dB(A). The overall vibration level does not exceed 2,5 m/sec².

WARNING

It is recommended to only use Johnson Outdoors approved accessories with your Minn Kota motor. Using non-approved accessories including to mount or control your motor may cause damage, unexpected motor operation and injury. Be sure to use the product and approved accessories, including remotes, safely and in the manner directed to avoid accidental or unexpected motor operation. Keep all factory installed parts in place including motor and accessory covers, enclosures and guards.

WARNING

In the event of unexpected operation, remove power leads from the battery.

CAUTION

This motor is not suitable for use in strong currents exceeding the thrust levels of the motor.

WARRANTY

WARRANTY ON MINN KOTA SALTWATER TROLLING MOTORS

Johnson Outdoors Marine Electronics, Inc. ("JOME") extends the following limited warranty to the original retail purchaser only. Warranty coverage is not transferable.

Minn Kota Limited Two-Year Warranty on the Entire Product

JOME warrants to the original retail purchaser only that the purchaser's new Minn Kota saltwater trolling motor will be materially free from defects in materials and workmanship appearing within two (2) years after the date of purchase. JOME will (at its option) either repair or replace, free of charge, any parts found by JOME to be defective during the term of this warranty. Such repair, or replacement shall be the sole and exclusive liability of JOME and the sole and exclusive remedy of the purchaser for breach of this warranty.

Exclusions & Limitations

This limited warranty does not apply to products that have been used commercially or for rental purposes. This limited warranty does not cover normal wear and tear, blemishes that do not affect the operation of the product, or damage caused by accidents, abuse, alteration, modification, shipping damages, negligence of the user or misuse, improper or insufficient care or maintenance. **DAMAGE CAUSED BY THE USE OF OTHER REPLACEMENT PARTS NOT MEETING THE DESIGN SPECIFICATIONS OF THE ORIGINAL PARTS WILL NOT BE COVERED BY THIS LIMITED WARRANTY.** The cost of normal maintenance or replacement parts which are not in breach of the limited warranty are the responsibility of the purchaser. Prior to using products, the purchaser shall determine the suitability of the products for the intended use and assumes all related risk and liability. Any assistance JOME provides to or procures for the purchaser outside the terms, limitations or exclusions of this limited warranty will not constitute a waiver of the terms, limitations or exclusions, nor will such assistance extend or revive the warranty. JOME will not reimburse the purchaser for any expenses incurred by the purchaser in repairing, correcting or replacing any defective products or parts, except those incurred with JOME's prior written permission. **JOME'S AGGREGATE LIABILITY WITH RESPECT TO COVERED PRODUCTS IS LIMITED TO AN AMOUNT EQUAL TO THE PURCHASER'S ORIGINAL PURCHASE PRICE PAID FOR SUCH PRODUCT.**

Minn Kota Service Information

To obtain warranty service in the U.S., the product believed to be defective, and proof of original purchase (including the date of purchase), must be presented to a Minn Kota Authorized Service Center or to Minn Kota's factory service center in Mankato, MN. Any charges incurred for service calls, transportation or shipping/freight to/from the Minn Kota Authorized Service Center or factory, labor to haul out, remove, re-install or re-rig products removed for warranty service, or any other similar items are the sole and exclusive responsibility of the purchaser. Products purchased outside of the U.S. must be returned prepaid with proof of purchase (including the date of purchase and serial number) to any Authorized Minn Kota Service Center in the country of purchase. Warranty service can be arranged by contacting a Minn Kota Authorized Service Center or by contacting the factory at 1-800-227-6433 or email service@minnkotamotors.com. **Products repaired or replaced will be warranted for the remainder of the original warranty period [or for 90 days from the date of repair or replacement, whichever is longer]. For any product that is returned for warranty service that JOME finds to be not covered by or not in breach of this limited warranty, there will be a billing for services rendered at the prevailing posted labor rate and for a minimum of at least one hour.**

NOTICE: Do not return your Minn Kota product to your retailer. Your retailer is not authorized to repair or replace products.

NOTICE: THERE ARE NO EXPRESS WARRANTIES OTHER THAN THESE LIMITED WARRANTIES. IN NO EVENT SHALL ANY IMPLIED WARRANTIES INCLUDING ANY IMPLIED WARRANTIES OF MERCHANTABILITY OR FITNESS FOR PARTICULAR PURPOSE, EXTEND BEYOND THE DURATION OF THE RELEVANT EXPRESS LIMITED WARRANTY. IN NO EVENT SHALL JOME BE LIABLE FOR PUNITIVE, INDIRECT, INCIDENTAL, CONSEQUENTIAL OR SPECIAL DAMAGES. Without limiting the foregoing, JOME assumes no responsibility for loss of use of product, loss of time, inconvenience or other damage.

Some states do not allow limitations on how long an implied warranty lasts or the exclusion or limitation of incidental or consequential damages, so the above limitations and/or exclusions may not apply to you. This warranty gives you specific legal rights and you may also have other legal rights which vary from state to state.

KNOW YOUR BOAT

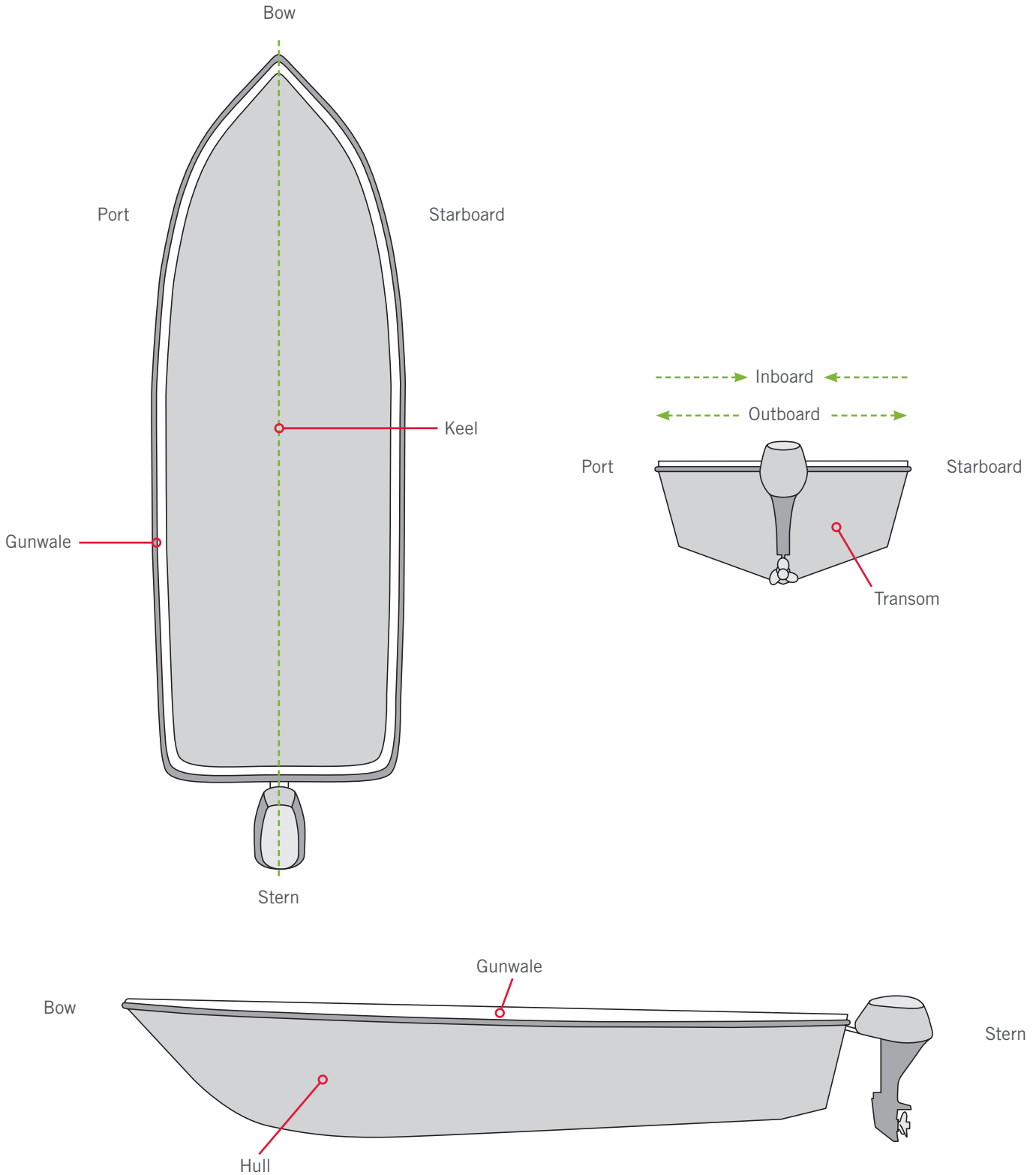

FEATURES

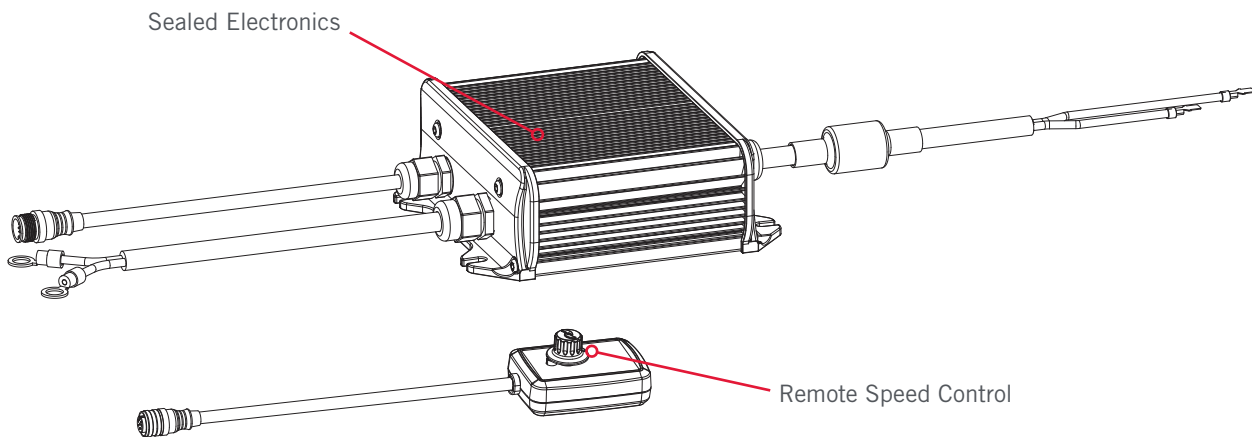
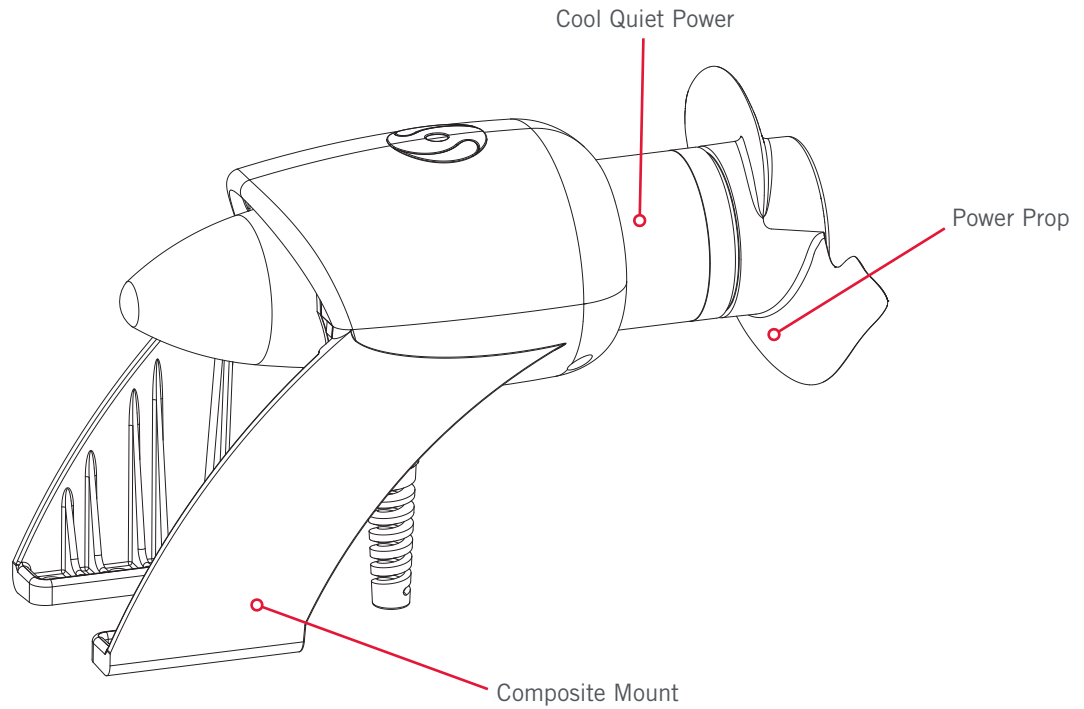

NOTICE: Specifications subject to change without notice. This diagram is for reference only and may differ from your actual motor.

INSTALLATION

INSTALLING THE ENGINE MOUNT

Your Engine Mount comes with everything you'll need to directly install it to the engine. To install the Engine Mount directly to the motor, please follow the instructions provided in this manual. Please review the parts list, mounting considerations and tools needed for installation prior to getting started. For additional product support, please visit minnkotamotors.com.

INSTALLATION PARTS LIST

Item / Assembly	Part #	Description	Qty.
A Items 2-22	2994856	BAG ASSY, EM	1
2	2383422	SCREW-3/8-16 X 1 1/4 HHCS SS	6
4	2381726	WASHER-FENDER 3/8 X 1 1/4" SS	6
6	2381728	WASHER-FLAT 3/8" THICK SS SAE	6
8	2383122	NUT 3/8-16 NYLON INST LOCKNUT	6
10	2375401	SHRINK TUBE, 2.00 X 3/8	4
12	2256300	TIE WRAP-5.5" BLACK [D080	6
14	9950950	HOOK-1.5" X 2" HOOK & LOOP,BLK	1
16	9950953	LOOP-1.5" X 2" HOOK & LOOP,BLK	1
18	2373427	SCREW-BOAT-#12 X 5/8 PPH (N/A)	4
20	2385110	INSULATOR PAD, EM	2
22	2014800 ▲	BAG-ZPLCK (4X6) 4ML Clear	1
B	*	ENGINE MOUNT ASSEMBLY	1
C	2990241	HAND CONTROLLER ASSY, EM	1
D	2990246	CTRL MOD ASY 12V, SINGLE	1

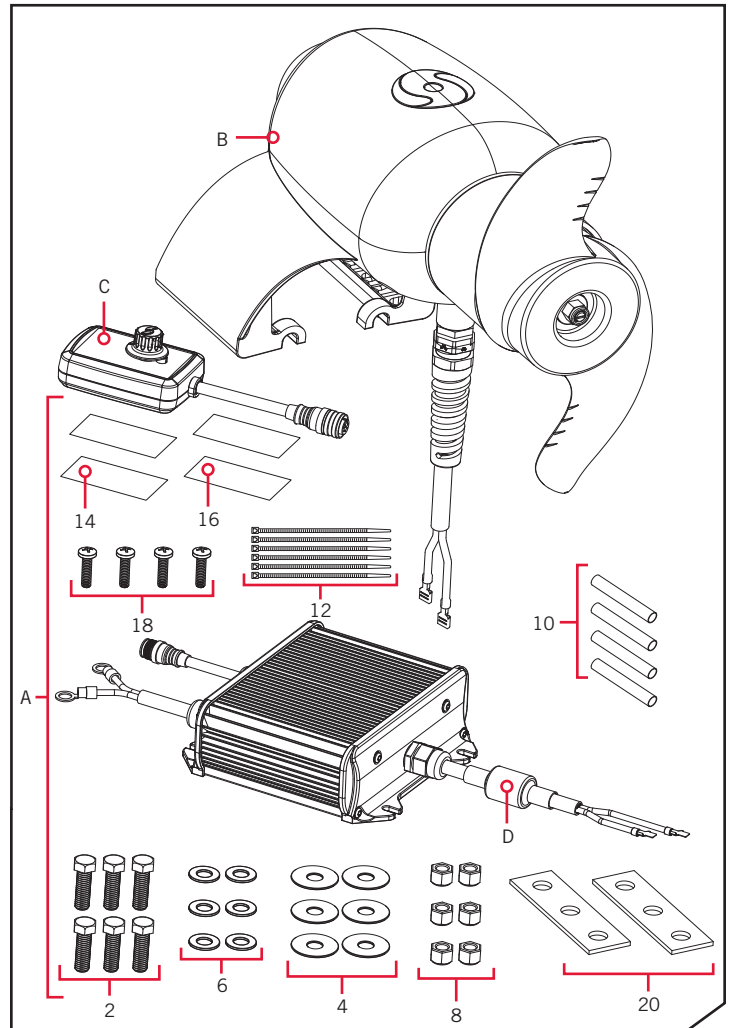

* This part is included in an assembly and cannot be ordered individually.

▲ Not shown on Parts Diagram.

MOUNTING CONSIDERATIONS

Before installing your Minn Kota motor, make sure that the model you have selected is right for your boat and motor. Use the chart below to verify you have selected the right size motor based on the recommendations below.

Boat Length	14 feet	16 feet	18 feet	20 feet	22 feet	24 feet	26 feet
Motor Selection Recommendation	Engine Mount - 12 volt						
	80 lb Engine Mount - 24 volt						
	101 lb Engine Mount - 36 volt						
	160 lb Engine Mount - 24 volt						

Review these Mounting Considerations to determine if your boat meets the minimum water depth. Measure the water depth to make sure that your boat rides low enough in the water so that the Engine Mount motor and propeller will be fully submerged. Make sure you measure from the waterline to the top of the Anti-ventilation Plate of the Outboard Engine. The Outboard Engine on your boat will need to trim down so that there is at minimum of 13 inches from the Anti-ventilation Plate to the surface of the water for proper operation.

Anti-ventilation plate must be at least 4.5" long and 6" wide to accommodate an Engine Mount motor. The spine of the motor cannot be wider than 3.2" at the mounting area.

Because of its unique mounting location, usage of Engine Mount may be restricted on certain smaller and /or lighter weight boats. A minimum water depth is required for proper operation.

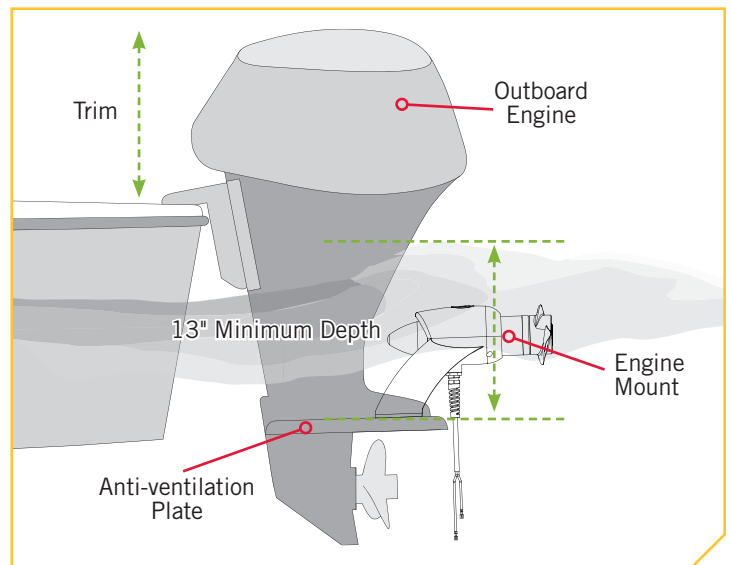

Check your boat for possible interference that may be caused by swimming platforms, trim and tilt mechanisms and other attachments that could interfere with the Minn Kota motor once it is installed. Be sure to check for clearances with your engine both in its down position and in its up or tilt position. If you have any questions on whether the Minn Kota motor you have selected can be properly installed on your boat, call our customer service number at: 1-800-227-6433.

WARNING

Engine Mount Trolling Motors are designed to be center mounted only. Mounting an Engine Mount outside of a boat's centerline can cause damage to the Engine Mount or to the boat engine. Water craft with more than a single outboard are generally not a proper application for the Engine Mount. Not installing the Engine Mount as recommended may cause harm or injury.

TOOLS AND RESOURCES REQUIRED

- Drill
- 3/8" Drill Bit
- 1/8" Drill Bit
- 9/16" Wrench
- 9/16" Socket Wrench with extension
- Phillips head screw driver
- Two clamps to help hold the mounting bracket in place
- Heat Gun

INSTALLATION

INSTALLATION >

> Installing the Engine Mount

1

ITEM(S) NEEDED

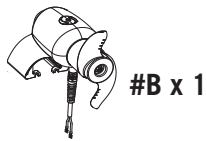

WARNING

Remove the ignition key before beginning installation to prevent accidental starting of Outboard Engine during installation.

- a. Make sure that the key is removed from the ignition and review the Mounting Considerations to determine an acceptable mounting location on the Anti-ventilation Plate. The Engine Mount came already installed in the Mounting Bracket. Keep the Engine Mount in the Mounting Bracket and position the Engine Mount Assembly (Item #B) onto the Anti-ventilation Plate of the Outboard Engine. Place the Engine Mount as close to the Outboard Engine as possible. In some cases the Mounting Bracket may need to be flexed in or out to insure a good fit on the Anti-ventilation Plate.

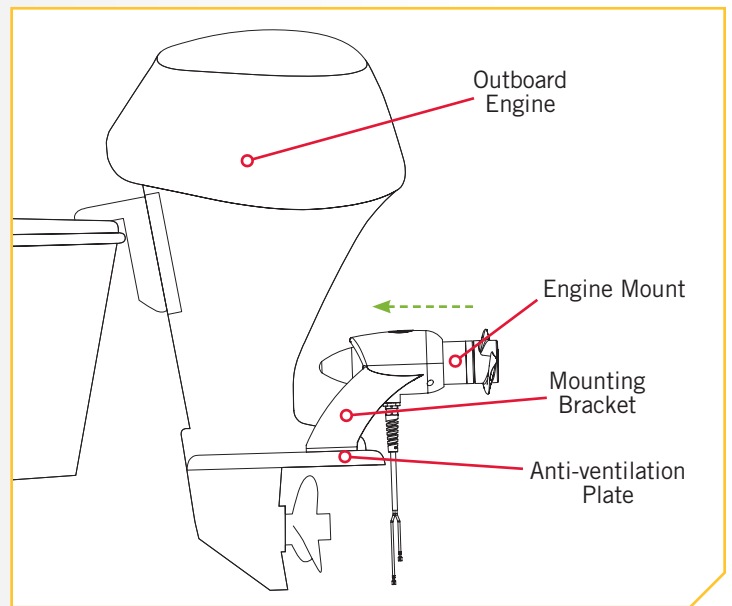

2

ITEM(S) NEEDED



- b. Clamp or hold the Mounting Bracket in place and carefully mark the Anti-ventilation plate at each Mounting Hole on the Mounting Bracket. Remove the Clamps and set the motor aside.
- c. Use a Drill with a 3/8" Drill Bit to drill through the Anti-ventilation Plate on the marked locations.
- d. Place the Insulator Pad (Item #20) between the feet of the Mounting Bracket and the Anti-ventilation Plate and clamp or hold the motor back in place aligning the Mounting Holes with the Drilled locations.

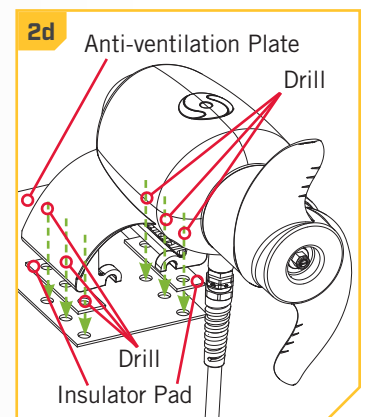
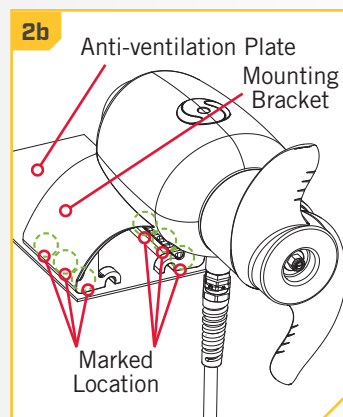

3

ITEM(S) NEEDED



- e. Place one 3/8" Washer (Item #6) on the end of each of the six 3/8"-16 x 1-1/4" Hex Head Cap Screw (Item #2). Put one Screw in each of the Mounting Holes so that they first pass through the Mounting Bracket, then the Insulator Pad and then the Anti-ventilation Plate.
- f. Route the Cable from the Engine Mount into the boat through a cable port or any other available opening. It is recommended to use any existing Cable Hooks if they are present.
- g. On some boats, it may be necessary to add a Cable Port through the Transom. If necessary, consult your marine dealer for appropriate hardware.

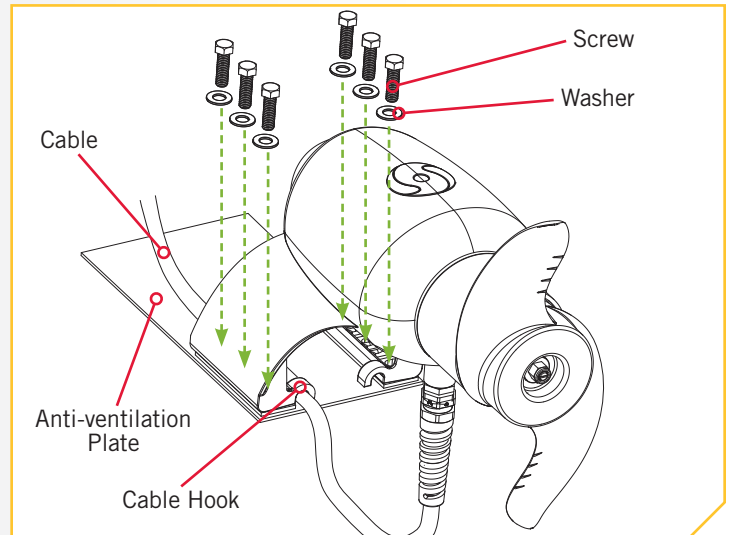

4

ITEM(S) NEEDED



- h. Using six of the Fender Washers (Item #4), place one Washer on the end of each Screw and secure each with a Nylon Lock Nut (Item #8).
- i. Be sure to leave enough slack in the cable to raise and lower the Outboard Engine. Use the Cable Ties supplied (Items #12) to secure the Engine Mount cable to the engine housing or to other cables on the boat to prevent snagging, and to make sure that the cable does not become lodged underneath the engine bracket when it is raised and lowered. Make sure the cable between the Motor and Cable Hook is snug and does not have excessive slack.
- j. Check that the cable does not get caught or kinked by turning the Outboard Engine in its full range from side to side or from lock to lock. The Cable from the Electric Outboard will be connected to the Cable from the Control Module later in the installation.

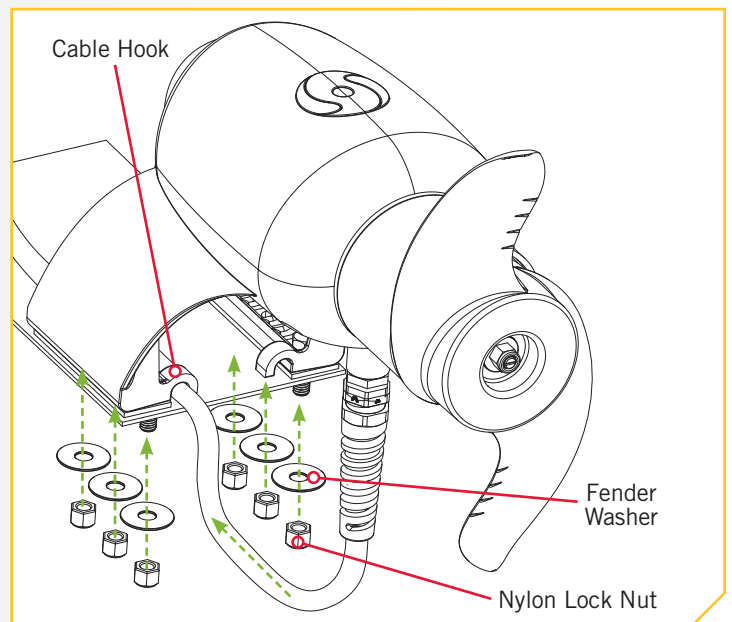

INSTALLATION

› Installing the Control Module and Connecting it to the Motor

The Control Module contains all of the electronics that are used to control the speed of your Engine Mount. It is recommended to mount the Control Module on a flat surface in or near the battery compartment. Make sure that the motor Lead Wires coming from the Engine Mount can reach the Lead Wires on the Control Module. The Lead Wires on the Control Module are on the opposite end of the Control Module from the Hand Control Connection Wire. The Hand Control Connection Wire is identified by a pin plug with a threaded connection.

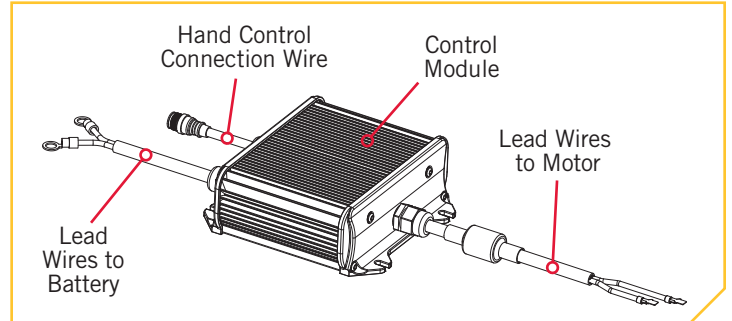

1

ITEM(S) NEEDED

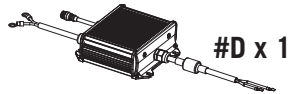

WARNING

Remove the ignition key before beginning installation to prevent accidental starting of Outboard Engine during installation.

- Make sure that the key is removed from the ignition and review the Mounting Considerations to determine an acceptable mounting location.
- Take the Control Module (Item #D) and double check the mounting location. Use a Marking Tool to mark the four Mounting Holes of the Control Module on the mounting location. Take the Control Module and set it aside.
- Take a Drill with a 1/8" Drill Bit and drill four pilot holes on the marked locations.
- Replace the Control Module and secure it with the four Boat Screws (Item #18) into the pilot holes.

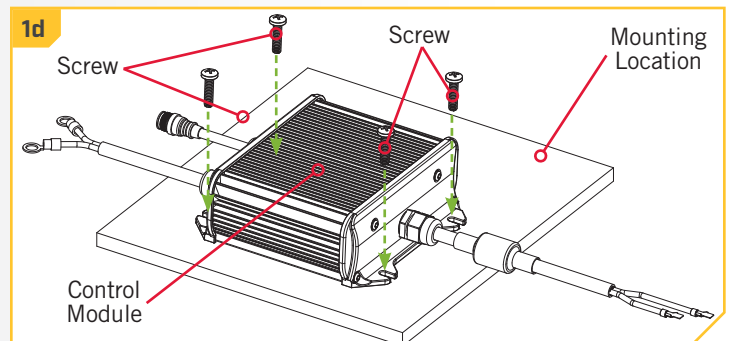
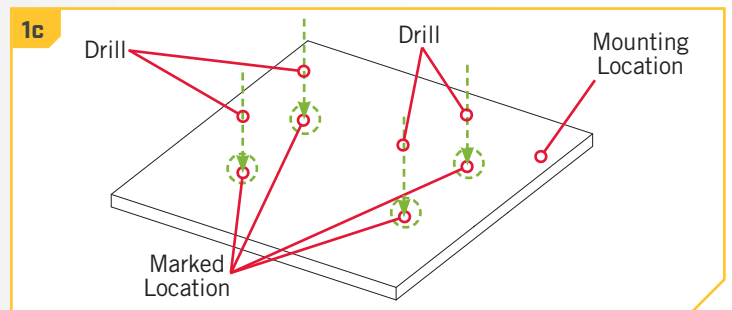
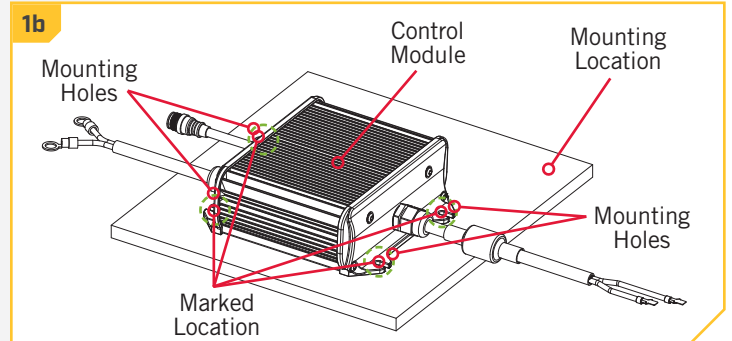

2

ITEM(S) NEEDED

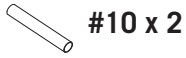

- e. Once the Control Module is secured, the power leads to the motor need to be connected. Take the Positive (+) Lead Wire (violet) from the Control Module and slip a Heat Shrink (Item #10) over it. Connect the Positive (+) Lead Wire (violet) from the Control Module to the Positive (+) Lead Wire (violet) from the motor.
- f. Slip a Heat Shrink over the Negative (-) Lead Wire (gray) from the Control Module. Connect the Negative (-) Lead Wire (gray) from the Control Module to the Negative (-) Lead Wire (gray) from the motor.

NOTICE: Do not apply lubricant or any type of grease to trolling motor connectors.

- g. Center both Heat Shrinks and secure them by sealing the Heat Shrinks over the connections with a heat gun.
- h. Route the wires in a way that they will not be a tripping hazard. Secure any excess wires by tucking them away or securing them with a tie.

WARNING

Route the cables from the Control Module to the Motor in a way that they do not cause a tripping hazard.

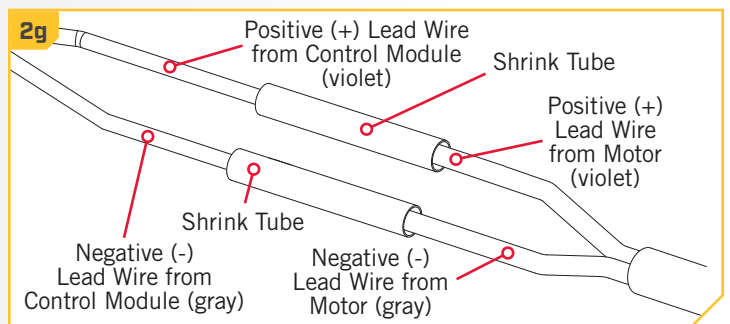
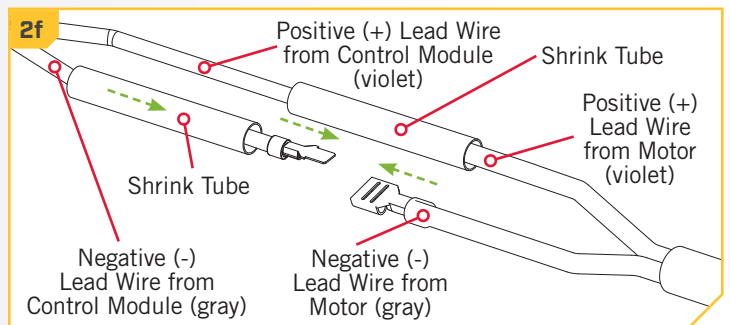
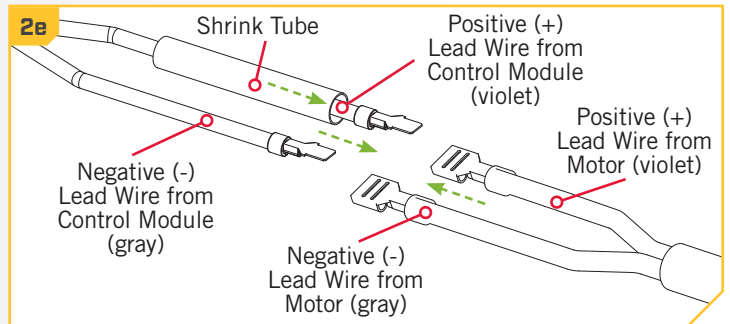

INSTALLATION

› Installing the Hand Controller and Connecting it to the Control Module

The Hand Controller comes equipped with approximately 18 feet of cable and is designed to be installed at or near the driver's seat. Hook and Loop with self adhesive is supplied to mount the Hand Controller to any smooth surface. This allows you to remove the Hand Controller and operate it from anywhere in the boat. The controller, for example, can be mounted on or near the dash board, placed by the throttle control for the main engine or on the side of the driver's seat. Be sure the surface where you are going to mount the controller is clean and dry.

WARNING

Arcing (sparking) can cause batteries to explode. To prevent arcing, always place the Speed Control Knob to the "OFF" position before connecting the cables.

1

ITEM(S) NEEDED



#14 x 1



#16 x 1

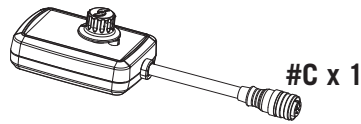

#C x 1

- Take the Hand Controller (Item #C) and determine a mounting location by reviewing the mounting considerations at the beginning of this section. Take the Loop side of the Fabric Pad supplied (Item #14) and remove the adhesive backing. Stick it to the back of the Hand Controller.
- Make sure that the Mounting Location is clean and dry. Take the Hook side of the Fabric Pad (Item #16) and stick it to the mounting location. Press the Hook and Loop Fabric Pad together.

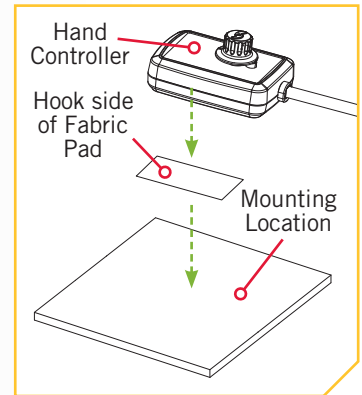
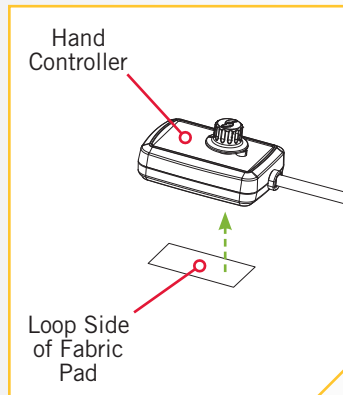

2

- Make sure the Hand Controller is in the "OFF" position.
- Route the cable from the Hand Controller through a side wall or along the edge of the floor of the boat to the battery area where the Control Module is located.
- Plug in the Hand Controller cable to the matching cable on the back side of the Control Module. Make sure this cable is threaded together snug and secure.
- Route the wires in a way that they will not be a tripping hazard. Secure any excess wires by tucking them away or securing them with a tie.

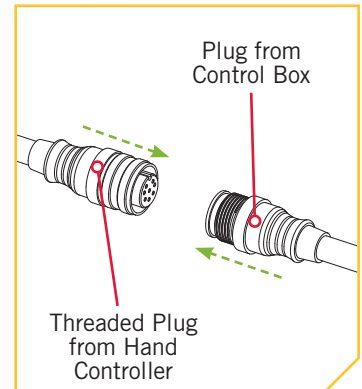
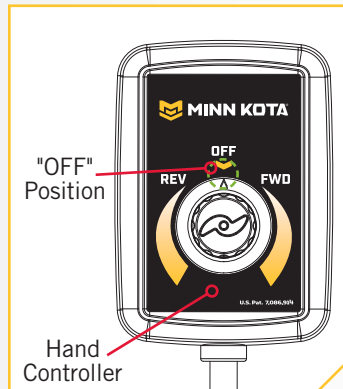

WARNING

Route the cables from the Control Module to the Hand Controller in a way that they do not cause a tripping hazard.

NOTICE: The Cable for the Hand Controller is threaded with a 5 point plug.

BATTERY & WIRING INSTALLATION

BOAT RIGGING & PRODUCT INSTALLATION

For safety and compliance reasons, we recommend that you follow American Boat and Yacht Council (ABYC) standards when rigging your boat. Altering boat wiring should be completed by a qualified marine technician. The following specifications are for general guidelines only:

CAUTION

These guidelines apply to general rigging to support your Minn Kota motor. Powering multiple motors or additional electrical devices from the same power circuit may impact the recommended conductor gauge and circuit breaker size. If you are using wire longer than that provided with your unit, follow the conductor gauge and circuit breaker sizing table below. If your wire extension length is more than 25 feet, we recommend that you contact a qualified marine technician.

CAUTION

An over-current protection device (circuit breaker or fuse) must be used. Coast Guard requirements dictate that each ungrounded current-carrying conductor must be protected by a manually reset, trip-free circuit breaker or fuse. The type (voltage and current rating) of the fuse or circuit breaker must be sized accordingly to the trolling motor used. The table below gives recommended guidelines for circuit breaker sizing.

CONDUCTOR GAUGE AND CIRCUIT BREAKER SIZING TABLE

This conductor and circuit breaker sizing table is only valid for the following assumptions:

1. No more than 2 conductors are bundled together inside of a sheath or conduit outside of engine spaces.
2. Each conductor has 105° C temp rated insulation.
3. No more than 5% voltage drop allowed at full motor power based on published product power requirements.

Motor Thrust / Model	Max Amp Draw	Circuit Breaker	Wire Extension Length				
			5 feet	10 feet	15 feet	20 feet	25 feet
30 lb.	30	50 Amp @ 12 VDC	10 AWG	10 AWG	8 AWG	6 AWG	4 AWG
40 lb., 45 lb.	42		10 AWG	8 AWG	6 AWG	4 AWG	4 AWG
50 lb., 55 lb.	50	60 Amp @ 12 VDC	8 AWG	6 AWG	4 AWG	4 AWG	2 AWG
70 lb.	42	50 Amp @ 24 VDC	10 AWG	10 AWG	8 AWG	8 AWG	6 AWG
80 lb.	56	60 Amp @ 24 VDC	8 AWG	8 AWG	8 AWG	6 AWG	6 AWG
101 lb.	46	50 Amp @ 36 VDC	8 AWG	8 AWG	8 AWG	8 AWG	8 AWG
Engine Mount 101	50	60 Amp @ 36 VDC	8 AWG	8 AWG	8 AWG	8 AWG	8 AWG
112 lb.	52	60 Amp @ 36 VDC	8 AWG	8 AWG	8 AWG	8 AWG	8 AWG
Engine Mount 160	116	120 Amp @ 24 VDC	6 AWG	6 AWG	4 AWG	2 AWG	2 AWG
E-Drive	40	50 Amp @ 48 VDC	10 AWG	10 AWG	10 AWG	10 AWG	10 AWG

NOTICE: Wire Extension Length refers to the distance from the batteries to the trolling motor leads. Consult website for available thrust options. Maximum Amp Draw values only occur intermittently during select conditions and should not be used as continuous amp load ratings.

Reference

United States Code of Federal Regulations: 33 CFR 183 – Boats and Associated Equipment ABYC E-11: AC and DC Electrical Systems on Boats

SELECTING THE CORRECT BATTERIES



SELECTING THE CORRECT BATTERIES

The motor will operate with any lead acid, deep cycle marine 12 volt battery/batteries. For best results, use a deep cycle, marine battery with at least a 105 amp-hour rating. Maintain battery at full charge. Proper care will ensure having battery power when you need it, and will significantly improve the battery life. Failure to recharge lead-acid batteries (within 12-24 hours) is the leading cause of premature battery failure. Use a multi-stage charger to avoid overcharging. We offer a wide selection of chargers to fit your charging needs. If you are using a crank battery to start a gasoline outboard, we recommend that you use a separate deep cycle marine battery/batteries for your Minn Kota trolling motor. For more information on battery selection and rigging, please visit minnkotamotors.com.

WARNING

Never connect the (+) and the (-) terminals of the same battery together. Take care that no metal object can fall onto the battery and short the terminals. This would immediately lead to a short and extreme fire danger.

CAUTION

Refer to “Conductor Gauge and Circuit Breaker Sizing Table” in the previous section to find the appropriate circuit breaker or fuse for your motor. For motors requiring a 60-amp breaker, the Minn Kota MKR-19 60-amp circuit breaker is recommended.

CAUTION

Please read the following information before connecting your motor to your batteries in order to avoid damaging your motor and/or voiding your warranty.

ADDITIONAL CONSIDERATIONS

› **Additional Accessories Connected to Trolling Motor Batteries**

Significant damage to your Minn Kota motor, your boat electronics, and your boat can occur if incorrect connections are made between your trolling motor batteries and other battery systems. Minn Kota recommends using an exclusive battery system for your trolling motor. Where possible, accessories should be connected to a separate battery system. Radios and sonar units should not be connected to any trolling motor battery systems as interference from the trolling motor is unavoidable. If connecting any additional accessories to any trolling motor battery system, or making connections between the trolling motor batteries and other battery systems on the boat, be sure to carefully observe the information below.

The negative (-) connection must be connected to the negative terminal of the same battery that the trolling motor negative lead connects to. In the diagrams below this battery is labeled “Low Side” Battery. Connecting to any other trolling motor battery will input positive voltage into the “ground” of that accessory, which can cause excess corrosion. Any damage caused by incorrect connections between battery systems will not be covered under warranty.

› **Automatic Jump Start Systems and Selector Switches**

Automatic jump start systems and selector switches tie the negatives of the connected batteries together. Connecting these systems to the “High Side” Battery or “Middle” Battery in the diagrams below and will cause significant damage to your trolling motor and electronics. The only trolling motor battery that is safe to connect to one of these systems is the “Low Side” Battery.

////////////////////////////////////

CONNECTING THE BATTERIES

› 12 Volt Systems

1. Make sure that the motor is switched off (speed selector on “OFF” or “0”).
2. Connect positive (+) red lead to positive (+) battery terminal.
3. Connect negative (-) black lead to negative (-) battery terminal.

WARNING

For safety reasons do not switch the motor on until the propeller is in the water. If installing a leadwire plug, observe proper polarity and follow instructions in your boat owner’s manual.

WARNING

- For safety reasons, disconnect the motor from the battery or batteries when the motor is not in use or while the battery/batteries are being charged.
- Improper wiring of 24/36 volt systems could cause battery explosion.
- Keep leadwire wing nut connections tight and solid to battery terminals.
- Locate battery in a ventilated compartment.

CONNECTING THE BATTERIES

CONNECTING THE BATTERIES IN SERIES (IF REQUIRED FOR YOUR MOTOR)

› 24 Volt Systems

Two 12 volt batteries are required. The batteries must be wired in series, only as directed in wiring diagram, to provide 24 volts.

1. Make sure that the motor is switched off (speed selector on "0").
2. Connect a connector cable to the positive (+) terminal of battery 1 and to the negative (-) terminal of battery 2.
3. Connect positive (+) red motor lead to positive (+) terminal on battery 2.
4. Connect negative (-) black motor lead to negative (-) terminal of battery 1.

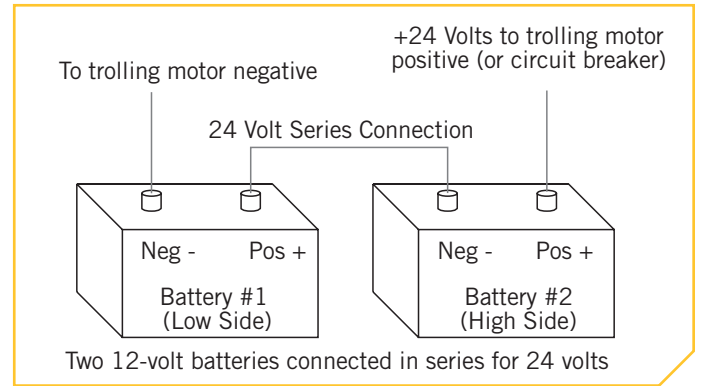

WARNING

For safety reasons do not switch the motor on until the propeller is in the water. If installing a leadwire plug, observe proper polarity and follow instructions in your boat owner's manual.

WARNING

- For safety reasons, disconnect the motor from the battery or batteries when the motor is not in use or while the battery/batteries are being charged.
- Improper wiring of 24/36 volt systems could cause battery explosion.
- Keep leadwire wing nut connections tight and solid to battery terminals.
- Locate battery in a ventilated compartment.

WIRING DIAGRAM

ENGINE MOUNT

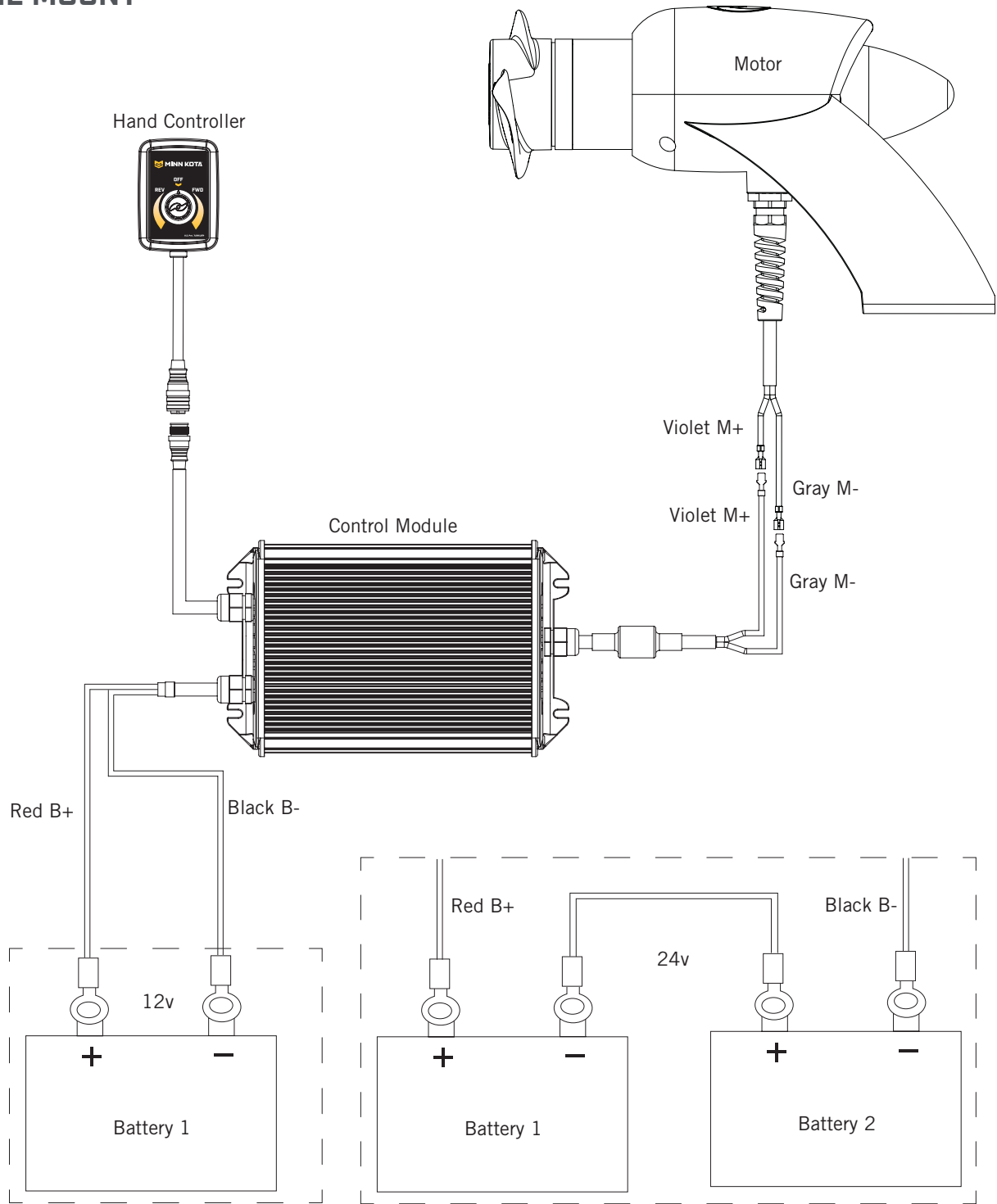

NOTICE: This is a multi-voltage diagram. Double-check your motor's voltage for proper connections. Over-Current Protection Devices are not shown in this illustration.

USING & ADJUSTING THE MOTOR

MOTOR OPERATION

Become familiar with the features of the motor to maximize the capabilities this product offers.

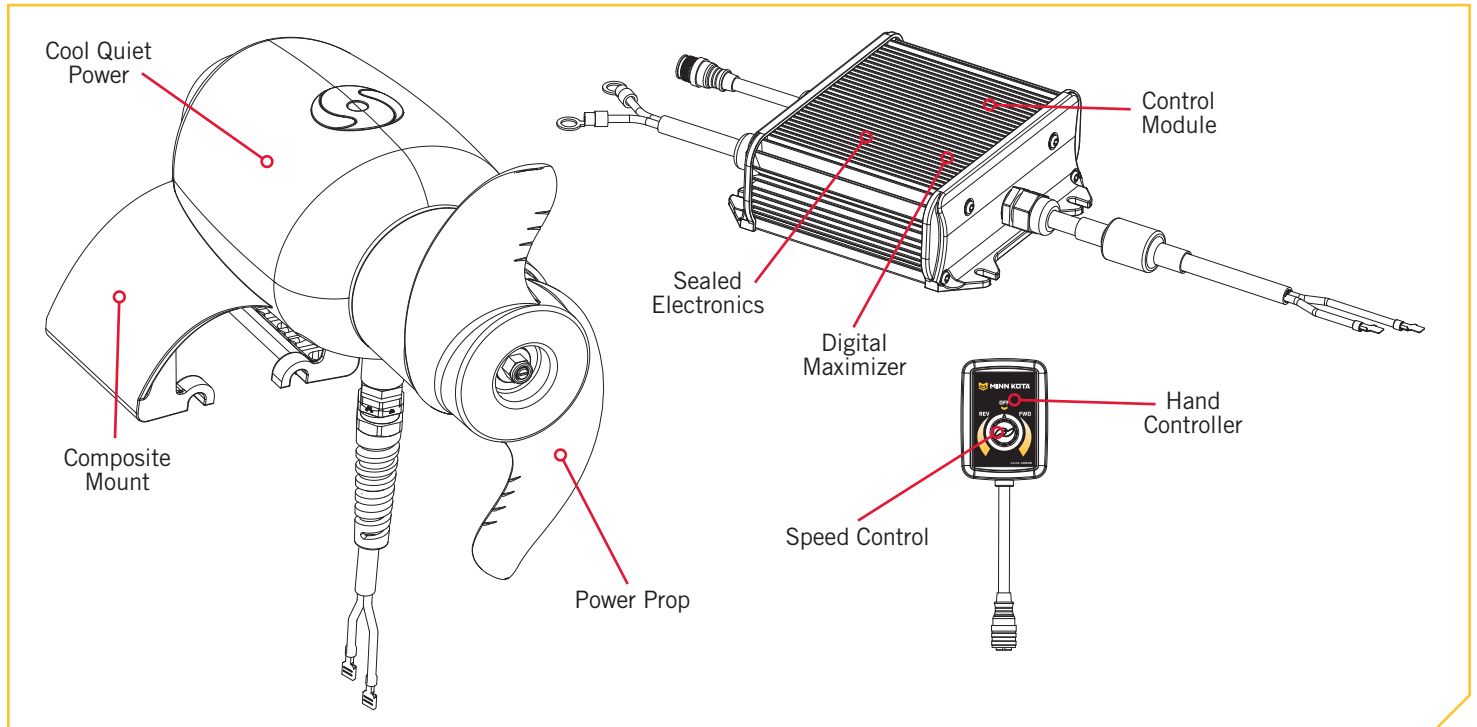

› Engine Mount Composite Mount

The Engine Mount discretely mounts on the Anti-ventilation Plate of your Outboard Engine or I/O unit, with no stowing or deploying required. The mount is made for everyday operation with rugged reliability and superior corrosion resistance. The motor stays out of sight, won't interfere with your I/O motor, keeps your deck clear and rides completely out of the water once you're on plane.

› Speed Control

Control your Engine Mount speed with this 18' corded Hand Controller. It can be mounted or hand-held, and offers infinitely variable speed control in forward and reverse. Features neutral (off) detent position. The motor can be steered using the boat's steering wheel or outboard tiller.

› Digital Maximizer

Motors with Digital Maximizer provide up to five times longer run time on a single charge by drawing only as much power as you need, so they don't waste any energy. These motors are variable speed, so dial in your precise speed and let Digital Maximizer deliver the right amount of power, while conserving your battery - extending your time on the water.

⚠ WARNING

The Engine Mount is not intended to be a primary propulsion motor. Heavy use of the motor can cause elevated temperatures, which can be increased by an excessively hot operating environment. Use care when handling the Control Module to avoid burns or injuries from excessive heat. In the event that the motor or speed control would break, always be prepared to take manual control of the boat.



› Sealed Electronics

EM electronics are housed in a fully waterproof control module mounted below the deck of the boat, and they're sealed in marine-grade polyurethane to provide corrosion-proof protection. The extruded aluminum housing features specially designed fins that dissipate heat to keep things cool under high rpm use.

› Cool Quiet Power

Nothing runs cooler or more quietly than a Minn Kota. Our extra large windings and commutators dissipate heat, resulting in cooler operation, extended battery power, and longer motor life. And our unique bearing system reduces friction to cut fish-spooking noise. So quiet, they'll never hear you coming.

› Power Prop

Delivers extra power to help you push through heavy vegetation to get you where the fish are.

 WARNING
When the motor is not in use, always turn the Speed Knob on the Hand Controller to "OFF". If the Speed Knob is set or accidentally engaged or bumped and is not positioned to "OFF" the prop will turn on unexpectedly. The prop may also turn on unexpectedly if the control board fails. Prevent injury from a turning propeller and always know how to quickly disengage the power or correct the Speed Knob to turn the prop off.

 WARNING
Be alert for unexpected boat movement when operating the Engine Mount. The boat may encounter sharp turns and jolts if the steering is changed sharply or if broad changes in speed are made while operating. Maintain balance and observe safe motor operation.

 WARNING
If the Hand Controller or Control Module break unexpectedly, be prepared to remove the power from the Engine Mount and re-gain manual control of your boat.

 CAUTION
Do not use the Engine Mount, Mounting Bracket, Control Module or other components of the Engine Mount as a step. The product will be slippery when wet and is not designed to support people. Using this product as a step may result in injury.



ADJUSTING THE DEPTH OF THE MOTOR

PROPER OPERATION

Once installed, the Engine Mount should be fully submerged when being used.

Trim the Outboard Engine, to bring the Engine Mount and propeller out of the water, before engaging in high speed propulsion with the Outboard Engine. Failure to properly trim the Outboard Engine can and will result in heavy steering. Since there are many different boat/motor configurations, you should trim the outboard “up” until proper steering returns.

To operate, the Engine Mount in the forward directions, slowly turn the Speed Control Knob in the forward direction. If everything is hooked up properly, the prop will turn in a clock-wise motion as viewed from the inside of the boat.

To operate, the Engine Mount in the reverse direction, slowly turn the Speed Control Knob in the reverse direction. If everything is hooked up properly, the prop will turn in a counter clockwise motion as viewed from the inside of the boat.

Use your boat’s steering wheel to turn your main engine and the Engine Mount either left or right.

To stop the propeller, turn the speed control knob to OFF. The speed control switch should remain in the “off” position when operating your outboard or during storage.

⚠ CAUTION

Continuous high speed operation with the unit submerged, can and will result in heavy steering and could cause severe damage to the motor or propeller.

NOTICE: Optimal operating condition is with the Outboard Engine trimmed down.

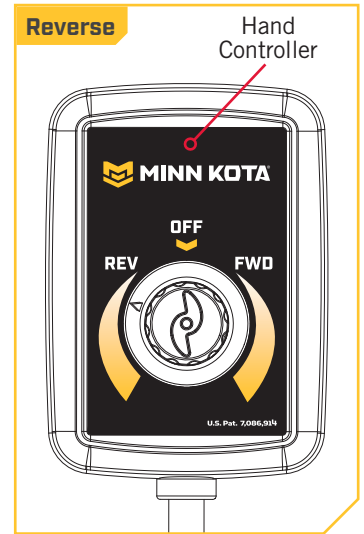
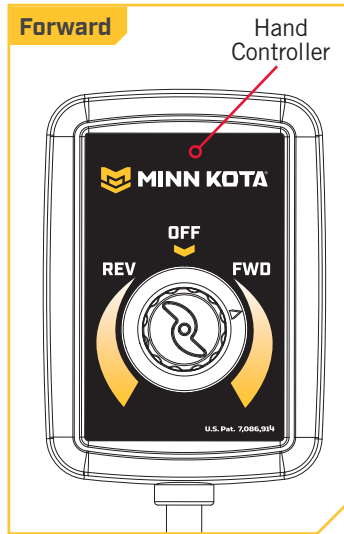
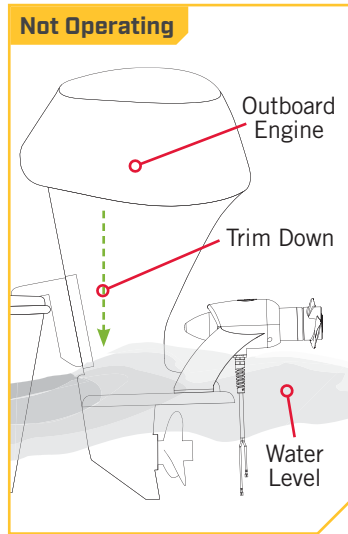
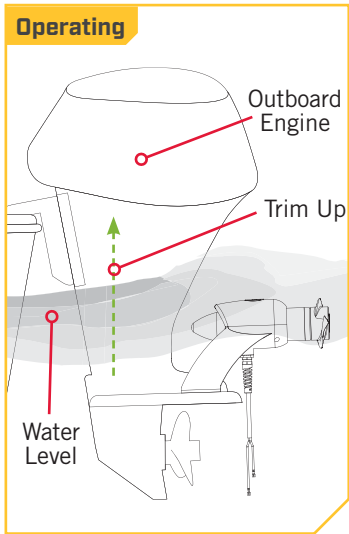

SERVICE & MAINTENANCE

PROPELLER REPLACEMENT

TOOLS AND RESOURCES REQUIRED >

- 1/2" Open End Wrench
- Flat Blade Screwdriver

INSTALLATION >

- Disconnect the motor from all sources of power prior to changing the propeller.
 - Hold the propeller and loosen the Prop Nut with a pliers or a wrench.
 - Remove the Prop Nut and Prop Washer.

NOTICE: If the Drive Pin is sheared or broken, you will need to hold the shaft stationary with a flat blade screwdriver pressed into the slot on the end of the shaft while you loosen the Prop Nut.

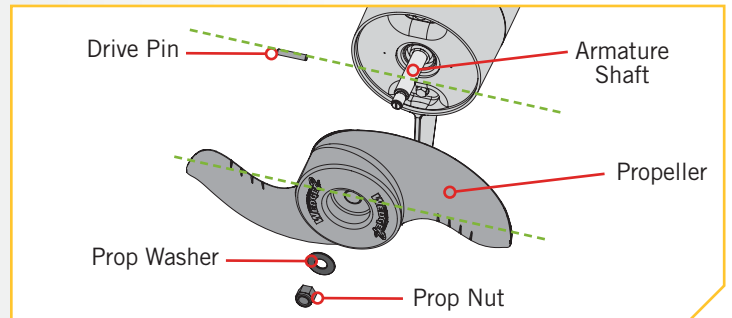

⚠ CAUTION

Disconnect the motor from the battery before beginning any prop work or maintenance.

- Turn the old prop to horizontal and pull it straight off. If drive pin falls out, push it back in.

⚠ CAUTION

If the prop does not readily slide off, take care to not bend the Armature Shaft while removing the prop by pulling the prop evenly off the Armature Shaft.

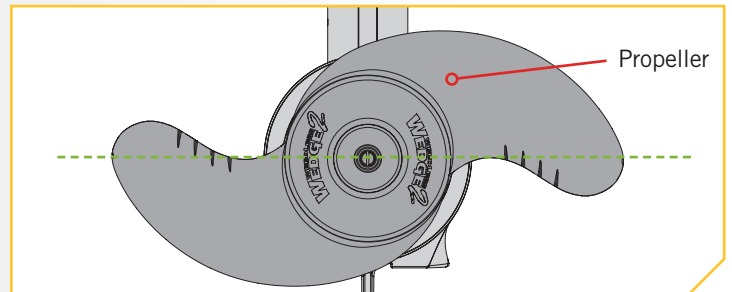

- Align the new Propeller with the Drive Pin.
 - Install the Prop Washer and Prop Nut.
 - Tighten the Prop Nut 1/4 turn past snug at 25-35 inch-lbs.

⚠ CAUTION

Do not over tighten as this can damage the prop.

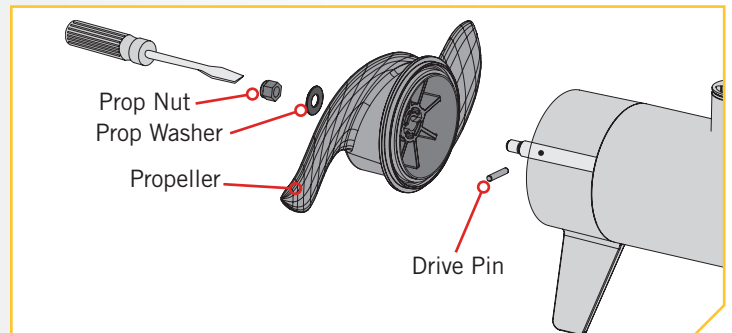

GENERAL MAINTENANCE



GENERAL MAINTENANCE

- After every use, the entire motor should be rinsed with freshwater, then wiped down with a cloth dampened with an aqueous based silicone spray. Do not spray water into the ventilation openings in the head of the motor.
- The propeller must be inspected and cleaned of weeds and fishing line after every use. Fishing line and weeds can get behind the prop, damage the seals and allow water to enter the motor.
- Verify the prop nut is secure each time the motor is used.
- To prevent accidental damage during transportation or storage, disconnect the battery whenever the motor is off of the water. For prolonged storage, lightly coat all metal parts with an aqueous based silicone spray.
- For maximum battery life, recharge the battery(s) as soon as possible after use. For maximum motor performance, restore battery to full charge prior to use.
- Keep battery terminals clean with fine sandpaper or emery cloth (flooded lead acid only).
- The propeller is designed to provide optimum operation with very high efficiency. To maintain this top performance, the leading edge of the blades must be kept smooth. If they are rough or nicked from use, restore to smooth by sanding with fine sandpaper.

TROUBLESHOOTING

1. Motor fails to run or lacks power:
 - Check battery connections for proper polarity.
 - Make sure terminals are clean and corrosion free. Use fine sandpaper or emery cloth to clean terminals.
 - Check battery water level. Add water if needed.
2. Motor loses power after a short running time:
 - Check battery charge. If low, restore to full charge.
3. You experience prop vibration during normal operation:
 - Remove and rotate the prop 180°. See removal instructions in the Propeller Replacement section.
4. Experiencing interference with your fishfinder:
 - You may, in some applications, experience interference in your depth finder display. We recommend that you use a separate deep cycle marine battery for your trolling motor and that you power the depth finder from the starting/cranking battery. If problems still persist, call our service department at 1-800-227-6433.

NOTICE: For all other malfunctions, visit an Authorized Service Center. You can search for an Authorized Service Center in your area by visiting our Authorized Service page, found on-line at minnkotamotors.com, or by calling our customer service number at 800-227-6433.

FOR FURTHER TROUBLESHOOTING AND REPAIR

FOR FURTHER TROUBLESHOOTING AND REPAIR

We offer several options to help you troubleshoot and/or repair your product. Please read through the options listed below.



Buy Parts Online

You can buy parts on-line directly from our website at minnkotamotors.com. Orders confirmed by 12 Noon Central Time, with Overnight Shipping selected, should ship the same business day if the parts are in stock. All other orders should ship within the next 3 business days, depending on the shipment method chosen, and if the parts are in stock.



Frequently Asked Questions

We have FAQs available on our website to help answer all of your Minn Kota questions. Visit minnkotamotors.com and click on “Frequently Asked Questions” to find an answer to your question.



Call Us (for U.S. and Canada)

Our consumer service representatives are available Monday – Friday between 7:00 a.m. – 4:30 p.m. CST at 800-227-6433. If you are calling to order parts, please have the 11-character serial number from your product, specific part numbers, and credit card information available. This will help expedite your call and allow us to provide you with the best consumer service possible. You can reference the parts list located in your manual to identify the specific part numbers.



Email Us

You can email our consumer service department with questions regarding your Minn Kota products. To email your question, visit minnkotamotors.com and click on “Support”.



Authorized Service Centers

Minn Kota has over 800 authorized service providers in the United States and Canada where you can purchase parts or get your products repaired. Please visit our Authorized Service Center page on our website to locate a service provider in your area.



Scan to visit Minn Kota service online.

COMPLIANCE STATEMENTS

ENVIRONMENTAL COMPLIANCE STATEMENT

It is the intention of JOME to be a responsible corporate citizen, operating in compliance with known and applicable environmental regulations, and a good neighbor in the communities where we make or sell our products.

WEEE DIRECTIVE

EU Directive 2002/96/EC “Waste of Electrical and Electronic Equipment Directive (WEEE)” impacts most distributors, sellers, and manufacturers of consumer electronics in the European Union. The WEEE Directive requires the producer of consumer electronics to take responsibility for the management of waste from their products to achieve environmentally responsible disposal during the product life cycle.

WEEE compliance may not be required in your location for electrical & electronic equipment (EEE), nor may it be required for EEE designed and intended as fixed or temporary installation in transportation vehicles such as automobiles, aircraft, and boats. In some European Union member states, these vehicles are considered outside of the scope of the Directive, and EEE for those applications can be considered excluded from the WEEE Directive requirement.

This symbol (WEEE wheelie bin) on product indicates the product must not be disposed of with other household refuse. It must be disposed of and collected for recycling and recovery of waste EEE. Johnson Outdoors Inc. will mark all EEE products in accordance with the WEEE Directive. It is our goal to comply in the collection, treatment, recovery, and environmentally sound disposal of those products; however, these requirements do vary within European Union member states. For more information about where you should dispose of your waste equipment for recycling and recovery and/or your European Union member state requirements, please contact your dealer or distributor from which your product was purchased.

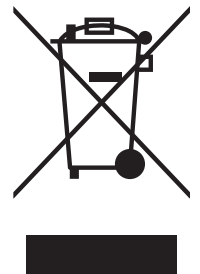

DISPOSAL

Minn Kota motors are not subject to the disposal regulations EAG-VO (electric devices directive) that implements the WEEE directive. Nevertheless never dispose of your Minn Kota motor in a garbage bin but at the proper place of collection of your local town council.

Never dispose of battery in a garbage bin. Comply with the disposal directions of the manufacturer or his representative and dispose of them at the proper place of collection of your local town council.

FCC COMPLIANCE

This device complies with Part 15 of the FCC rules. **Operation is subject to the following two conditions:**

1. This device may not cause harmful interference.
2. This device must accept any interference that may be received, including interference that may cause undesired operation.

Changes or modifications not expressly approved by Johnson Outdoors Marine Electronics, Inc. could void the user’s authority to operate this equipment.



NOTICE: This equipment has been tested and found to comply with the limits for a Class B digital device, pursuant to part 15 of the FCC Rules. These limits are designed to provide reasonable protection against harmful interference in a residential installation. This equipment generates, uses and can radiate radio frequency energy and, if not installed and used in accordance with the instructions, may cause harmful interference to radio communications. However, there is no guarantee that interference will not occur in a particular installation. **If this equipment does cause harmful interference to radio or television reception, which can be determined by turning the equipment off and on, the user is encouraged to try to correct the interference by one or more of the following measures:**

- Reorient or relocate the receiving antenna.
- Increase the separation between the equipment and receiver.
- Connect the equipment into an outlet on a circuit different from that to which the receiver is connected.
- Consult the dealer or an experienced radio/TV technician for help.

INDUSTRY CANADA COMPLIANCE

This product meets the applicable Industry Canada technical specifications. Operation is subject to the following two conditions: (1) this device may not cause interference, and (2) this device must accept any interference, including interference that may cause undesired operation of the device.

Changes or modifications not expressly approved by Johnson Outdoors Marine Electronics, Inc. could void the user’s authority to operate this equipment.

ENVIRONMENTAL RATINGS

- Ambient operating temperature range: -10C to 50C
- Ambient operating humidity range: 5% to 95%
- Maximum operating altitude: 10,000 feet



PARTS DIAGRAM & PARTS LIST

ENGINE MOUNT

12 VOLT

The parts diagram and parts list provides Minn Kota® WEEE compliance disassembly instructions. For more information about where you should dispose of your waste equipment for recycling and recovery and/or your European Union member state requirements, please contact your dealer or distributor from which your product was purchased. Tools required, but not limited to: flat head screwdriver, Phillips screwdriver, socket set, pliers, wire cutters.

ENGINE MOUNT MOTOR >

> Engine Mount Parts Diagram

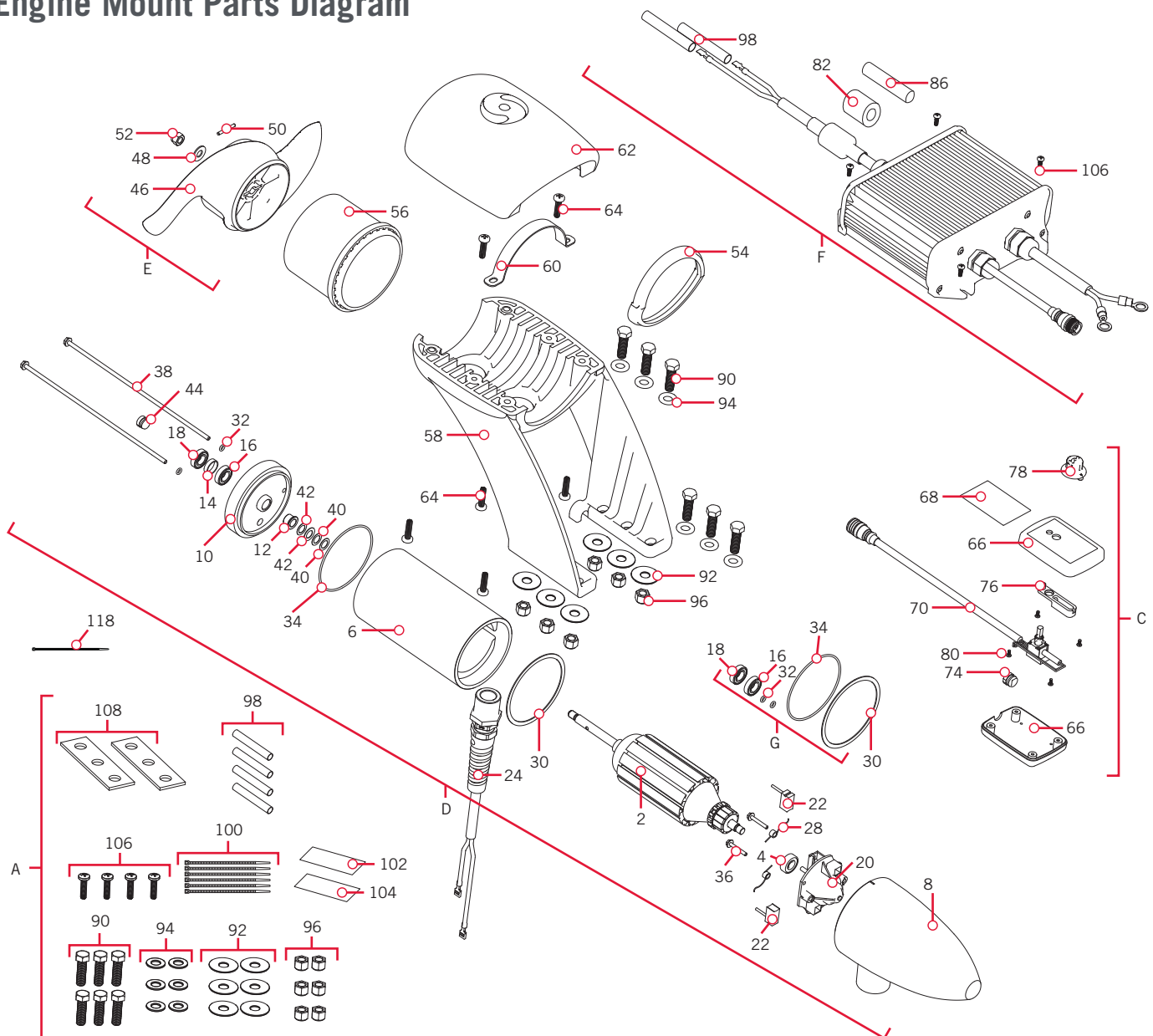

PARTS DIAGRAM & PARTS LIST

» Engine Mount Parts List

Assembly	Part #	Description	Quantity
A	2994856	BAG ASSY, EM	1
C	2990239	HAND CONTROLLER ASSY, EM	1
D	2387103	MTR ASY 12V 3.625 55# SW "EM"	1
E	1378170	PROP KIT PWR PRP	1
F	2990246	CTRL MOD ASY 12V, SINGLE	1
G	2888460	SEAL & O-RING KIT TURBO PRO *3.625*	1
Item	Part #	Description	Quantity
2	2-100-207	ARM ASY 12V 3.62 55#EM/LS	1
4	140-010	BEARING - BALL	1
6	2-200-301A	CTR HSG ASY 3.62 SW/TX-MGNTZ	1
8	421-302	BRSH END HSG 3.62 SW "EM"	1
10	2-400-338	PLAIN END HSG 3.625 "EM"	1
12	144-049	BEARING - FLANGE	1
14	725-035	PAPER TUBE - SEAL BORE	1
16	880-003	SEAL	1
18	880-006	SEAL WITH SHIELD	1
20	2-600-168	BRUSH PLATE ASSEMBLY- 3.625 EM	1
22	188-036	BRUSH ASSEMBLY 3.625	2
24	640-233	LEADWIRE ASSEMBLY 10 AWG	1
28	975-040	SPRING - TORSION	2
30	337-036	GASKET	1
32	701-008	O-RING	2
34	701-081	O-RING	1
36	830-007	SCREW, # 8-32	2
38	830-042	THRU BOLT 10-32 X 8.83	2
40	990-067	WASHER - STEEL THRUST	2
42	990-070	WASHER - NYLATRON	2
44	836-001	PLUG ALUMINUM 1/8 X 27 NPT	1
46	2091170	PROP-PWR (3 5/8") REAMED	1
48	2151726	WASHER-5/16 STD (S/S)	1
50	2092600	PIN-DRIVE 1.06" LG (SS)	1
52	2198400	ANODES, ZINC, 3.25/3.62" LWR UNT	1
54	2381530	ADAPTER RING, FRONT	1
56	2381535	ADAPTER RING, REAR	1
58	2381940	BRACKET, LOWER MOUNT	1
60	2383810	STRAP, EM	1
62	2380215	CAP-TOP (EM) SW	1

* This part is included in an assembly and cannot be ordered individually.

▲ Not shown on Parts Diagram.

PARTS DIAGRAM & PARTS LIST



Item	Part #	Description	Quantity
64	2383418	SCREW-1/4-10 X 1" PPH SS PLST	6
66	✖	ENCLOSURE,HAND CONTROL,EM	1
68	✖	DECAL-HAND CONTROL, EM	1
70	✖	CABLE/POT ASSY, EM	1
74	✖	DETENT,EM	1
76	✖	HOUSING-DETENT,EM	1
78	✖	KNOB,EM HAND CONTROL ASSY	1
80	✖	SCREW-#4-24 X 3/8 HI-LO SS	4
82	2307310	BEAD-FERRITE PD/AP	1
86	2075401	SHRINK TUBING,1.5 OD(CUT)(N/A)	1
88	2385810 ▲	LABEL,12V-RED SUPPLIER	1
90	2383422	SCREW-3/8-16 X 1 1/4 HHCS SS	6
92	2381726	WASHER-FENDER 3/8 X 1 1/4" SS	6
94	2381728	WASHER-FLAT 3/8" THICK SS SAE	6
96	2383122	NUT 3/8-16 NYLON INST LOCKNUT	6
98	2375401	SHRINK TUBE, 2.00 X 3/8	4
100	2256300	TIE WRAP-5.5" BLACK	6
102	9950950	HOOK-1.5" X 2" HOOK & LOOP,BLK	1
104	9950953	LOOP-1.5" X 2" HOOK & LOOP,BLK	1
106	2373427	SCREW-BOAT-#12 X 5/8 PPH (N/A)	4
108	2385110	INSULATOR PAD, EM	2
110	2014800 ▲	BAG-ZPLCK (4X6) 4ML CLEAR	1
112	2014830 ▲	BAG-16X24 1 ML STATIC FREE PLS	1
114	2387110 ▲	MANUAL, RT/EM	1
116	2384937 ▲	PARTS LIST, RT55EM	1
118	9953310	TIE WRAP- 8.5"	1

✖ This part is included in an assembly and cannot be ordered individually.

▲ Not shown on Parts Diagram.



NOTES

Notes area with horizontal lines and a dashed top border.

RECOMMENDED ACCESSORIES

ON-BOARD & PORTABLE BATTERY CHARGERS

Stop buying new batteries and start taking care of the ones you've got. Many chargers can actually damage your battery over time – creating shorter run times and shorter overall life. Digitally controlled Minn Kota chargers are designed to provide the fastest charge that protect and extend battery life.



MK212PC



MK210D



MK110PD

TALON SHALLOW WATER ANCHOR

Introducing the all-new, sleek redesigned Talon. Talon is the only shallow water anchor with up to 15' of anchoring depth, multiple anchoring modes, and control from the bow, transom, console, remote or mobile device.



BUILT-IN WORK LIGHT

Lets you tie lines and work from the transom any time of day — or night. Includes both white and blue LED lights with three brightness settings.



BLUETOOTH® CONNECTIVITY

Lets you control Talon from your mobile device and easily update it. Also opens up communication to other control options.



UP TO 15' DEEP

Control more water and catch more fish with the first 15' shallow water anchor.



MORE CONTROL OPTIONS

- Control Panel
- Wireless Remote
- Mobile App
- Wireless Foot Switch
- Humminbird® Connectivity
- i-Pilot® & i-Pilot Link™ Remote



MINN KOTA ACCESSORIES

We offer a wide variety of trolling motor accessories, including:

- 60-Amp Circuit Breaker
- Mounting Brackets
- Stabilizer Kits
- Extension Handles
- Battery Connectors
- Battery Boxes
- Quick Connect Plugs

