

PIRANHA 1 & 2 OPERATION GUIDE

Thank You

Thank you for purchasing a Piranha fishfinder from Humminbird, America's #1 Manufacturer of quality consumer marine electronics

WARNING! This device should not be used as a navigational aid to prevent collision, grounding, boat damage, or personal injury. When the boat is moving, water depth may change too quickly to allow time for you to react. Always operate the boat at very slow speeds if you suspect shallow water or submerged objects.

Installation Overview

Use the included installation guide to properly install your new Piranha. Installation must be done correctly to ensure best performance.

Using the Piranha

The Piranha is the easiest to use fishfinder ever. For most anglers, all you'll ever need to do is Power On & Fish! The Piranha automatically determines depth and makes adjustments to keep the bottom and fish visible on the display.

The Piranha uses sonar technology to send sound waves from the transducer into the water. The returned "echoes" are plotted on the Piranha's LCD display and create a very accurate picture of the underwater world with distance to underwater objects such as the bottom, fish and structure.

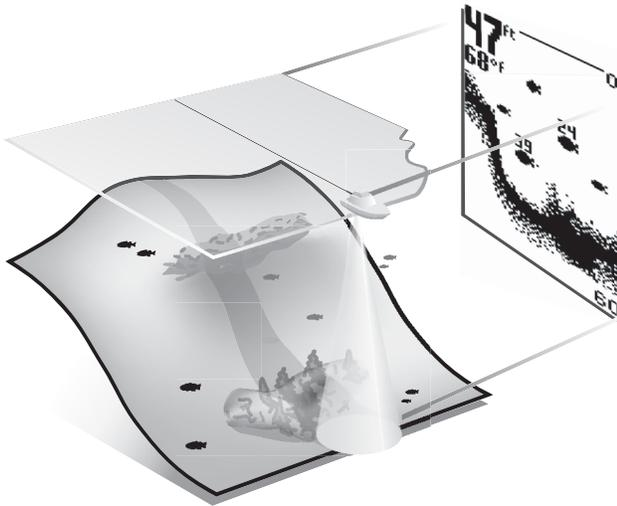

Powering ON and OFF

Press and release POWER-MENU to power the Piranha on. Press and hold POWER-MENU until the unit shuts down to power off.

When Piranha powers on, the Start Up menu temporarily appears. From this menu, select either Start-Up for on-the-water use, or Simulator for learning to use the system with simulated sonar data. The Start-Up menu disappears after several seconds and the Piranha begins operation.

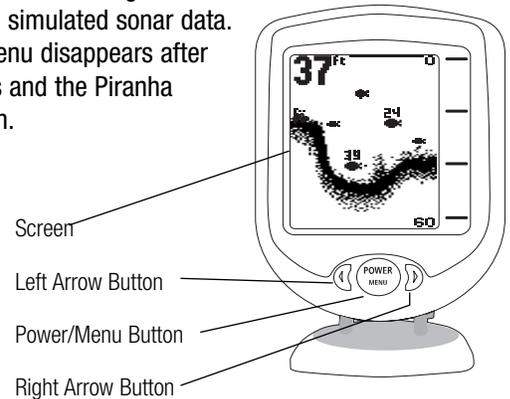

What You See On Screen

The Piranha displays underwater information in an easy-to-understand format. The top of the display corresponds to the water surface, and the bottom of the display corresponds to the Depth Range automatically selected for the current water depth. The Bottom Contour varies between the two as the depth under the boat changes. Digital readouts provide precise information for depth, fish and water temperature (separate purchase required).

**Note: Piranha 1's maximum depth is 240 feet. Piranha 2's maximum depth is 600 feet.*

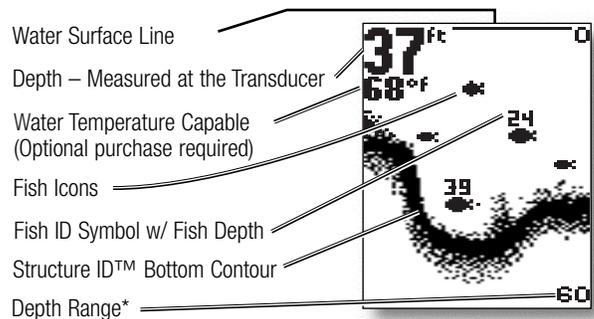

Understanding the On-screen Images

As the boat moves, terrain and bottom composition variations are displayed on-screen. Fish, bait fish and thermoclines (underwater temperature changes) are displayed when detected. Underwater conditions vary greatly, so some experience and interpretation is needed to realize all the benefits of the Piranha – use the picture below as a guide to the most common conditions and practice using the Piranha over known bottom types.

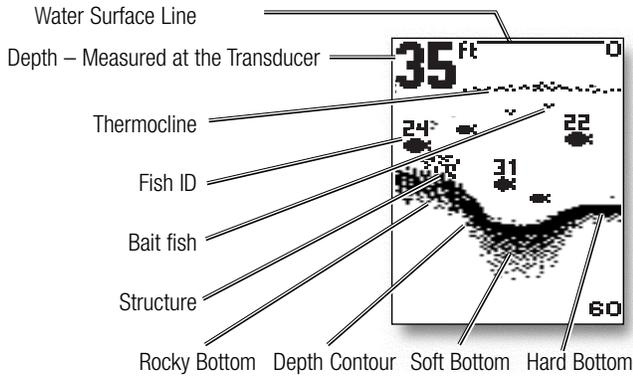

Accessing Menu Features

A simple menu system accesses Piranha's adjustable features. To activate the menu system, press POWER-MENU and a menu appears. Press POWER-MENU repeatedly to access other Piranha menus one at a time. When a menu is on the display, use the right and left arrow keys to adjust the menu. Menus automatically are removed from the screen after several seconds.

Note: Each time POWER-MENU is pressed, the backlight momentarily illuminates for easy viewing at night. Adjust the Light menu setting to keep the light on.

Note: If Simulator Mode is selected from the Startup Menu and a transducer is plugged in, menu settings are saved in memory. Menu settings are not saved from Simulator mode without a transducer connected.

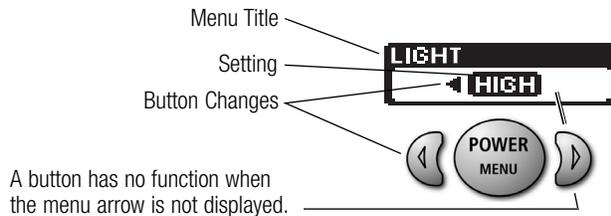

Light

(Setting Saved in Memory, Defaults to OFF)

Press POWER-MENU until the LIGHT menu appears. Select either OFF, LOW or HIGH to activate the backlight at the desired level.



Note: Continuous backlight operation significantly decreases battery life on Piranha Portables.

Sensitivity

(Setting Saved in Memory, Defaults to OFF)

Press POWER-MENU until the SENSITIVITY menu appears. Select a higher number to show smaller sonar returns on-screen, or a lower number to remove clutter from the screen. Adjusting Sensitivity also affects how sonar returns are identified as Fish ID Symbols - more fish will be detected at a higher setting, fewer at a lower setting. 5 is the Factory Setting.

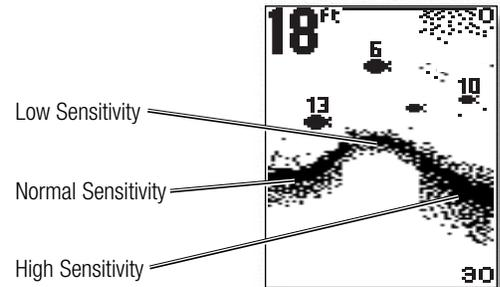

Depth Range Menu

(Setting Saved in Memory, Defaults to OFF)

Press POWER-MENU until the Depth Range menu appears. Select AUTO to have the Piranha automatically select the Depth Range or manually select 15, 30, 60, 120, 180, or 240 ft. for Piranha 1 and, in addition 360, 480 or 600 ft. for Piranha 2. This locks the depth range to a specific setting.



Note: In manual operation, if the depth is greater than the depth range setting, the bottom will not be visible on-screen. Select AUTO to return to automatic operation.

Bottom View Menu

(Setting Saved in Memory, Defaults to OFF)



Note: Bottom View is a Piranha 2 Feature Only

Press POWER-MENU until the Bottom View menu appears. Select Structure ID to gain bottom hardness and enhanced structure definition; Select Bottom Black for a high contrast, easy to view from a distance bottom picture.



Bottom Black Mode

Zoom

(Setting Saved in Memory, Defaults to OFF)



Press POWER-MENU until the Zoom menu appears. Select ON to magnify the area around the bottom thus revealing fish and structure close to the bottom that may not be visible in typical operation. In Zoom, the Piranha continually changes the upper and lower Depth Range to keep area just above and below the bottom on the display. Select OFF to return to normal operation.

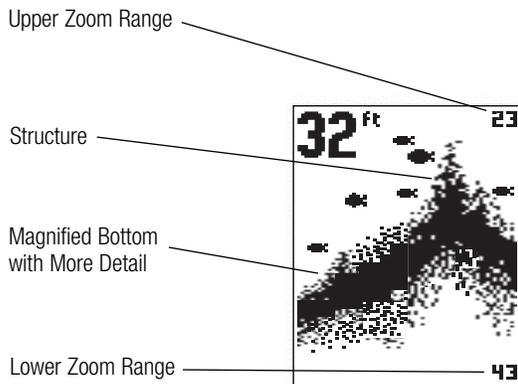

Depth Alarm

(Setting Saved in Memory, Defaults to OFF)



Press POWER-MENU until the DEPTH ALARM menu appears. Select OFF for no Depth Alarm; select a number from 3-99' to set the alarm depth point and turn it on. An audible alarm sounds when the depth is equal to or less than the setting.

Fish Alarm

(Setting Saved in Memory, Defaults to OFF)



Press POWER-MENU until the FISH ALARM menu appears. Select OFF for no fish alarm, or one of the following symbols to set the alarm point and turn it on.

- Alarms on big fish only.
- Alarms on big and medium fish only.
- Alarms on all fish.



Fish ID

(Setting Saved in Memory, Defaults to OFF)



Press POWER-MENU until the FISH ID menu appears. Select either OFF to view "raw" sonar returns, or ON to take advantage of Piranha's ability to identify sonar returns that are determined to be a fish. A select number of possible fish returns will be displayed with depth.



Maintenance

Your Piranha is designed to provide years of trouble-free operation with virtually no maintenance. Follow these simple procedures to ensure your Piranha continues to deliver top performance.

If the unit comes into contact with salt spray, wipe the affected surfaces with a cloth dampened in fresh water.

Do not use a chemical glass cleaner on the lens - this may cause cracking in the lens.

When cleaning the LCD protective lens, use a chamois and non-abrasive, mild cleaner. Do not wipe while dirt or grease is on the lens. Be careful to avoid scratching the lens.

If your boat remains in the water for long periods of time, marine growth can reduce the effectiveness of the transducer.

Periodically clean the face of the transducer with liquid detergent.

If your boat remains out of the water for a long period of time, it may take some time to wet the transducer when returned to the water. Small air bubbles can cling to the surface of the transducer and interfere with proper operation. These bubbles dissipate with time, or you can wipe the face of the transducer with your fingers after the transducer is in the water.

Never leave the unit in a closed car or trunk—the extremely high temperatures generated in hot weather can damage the electronics.

Troubleshooting

Do not attempt to repair the Piranha yourself. There are no user serviceable parts inside, and special tools and techniques are required for assembly to ensure the waterproof integrity of the housing. Repairs should be performed only by authorized Humminbird technicians.

Many requests for repair received by Humminbird involve units that do not actually need repair. These units are returned “no problem found.” If you have a problem with your Piranha, use the following troubleshooting guide before calling the Customer Resource Center or sending your unit in for repair.

1. Nothing happens when I turn the unit on.

Check the power cable connection at both ends. Be sure the cable is connected correctly to a reliable power source — red lead to positive, black lead to negative or ground. Ensure the power available is between 8 and 20 VDC. If the unit is wired through a fuse panel, ensure the panel is powered. Often accessory fuse panels are controlled by a separate switch or the ignition switch. Also, often a fuse can appear to be good when it is not. Check the fuse with a tester or replace it with a fuse known to be good.

Check the power connection to the Piranha. It is possible to force the power cable connector into the cable holder incorrectly. If the connector is reversed, the unit will not work. Examine the contacts on the back of the unit to ensure there is no corrosion.

2. There is no transducer detected.

The Piranha has the ability to detect and identify that a transducer is connected. When Powering on, if a message indicates “transducer not connected”, ensure that an appropriate transducer connector is plugged into the unit. Second, inspect the transducer cable from end to end for breaks, kinks, or cuts in the outer casing of the cable. Also ensure the transducer is fully submerged in water. If the transducer is connected to the unit through a switch, temporarily connect it directly to the unit and try again. If none of these items identifies an obvious problem, the transducer itself is probably the problem. Be sure to include the transducer if returning the unit for repair.

3. There is no bottom reading visible on the display.

If the loss of bottom information occurs only at high boat speeds, the transducer needs adjusting – see the Piranha Installation Guide. Also, in very deep water, it may be necessary to manually increase the sensitivity setting to maintain a graphic depiction of the bottom. If you are using a transducer switch to connect two transducers to the Piranha, ensure the switch is in the correct position to connect a transducer that is in water. (If a trolling motor transducer is selected and the trolling motor is out of water, no sonar information appears.) If none of the above solve the problem, inspect the transducer cable from end to end for breaks, kinks, or cuts in the outer casing of the cable. If the transducer is connected to the unit through a switch, temporarily connect it directly to the unit and try again. If none of these items identifies an obvious problem, the transducer itself may be the problem. Be sure to include the transducer if returning the unit for repair.

4. When in very shallow water, I get gaps in the bottom reading and inconsistent digital depth indication.

The Piranha will work reliably in water 3' (.9m) or deeper. The depth is measured from the transducer, not necessarily from the surface.

5. The unit comes on before I press POWER, and won't turn off.

Check the transducer cable — if the outer jacket of the cable has been cut and the cable is in contact with bare metal, you will need to repair the cut with electrical tape.

If there is no problem with the cable, disconnect the transducer from the unit and see if the problem is corrected, to confirm the source of the problem.

6. I get gaps in the reading at high speeds.

Your transducer needs adjusting. If the transducer is transom-mounted, there are two adjustments available to you—height, and running angle. Make small adjustments and run the boat at high speeds to determine the effect. It may take several tries to optimize high-speed operation. This can also be a result of air or turbulence in the transducer location caused by rivets, ribs, etc.

7. My unit loses power at high speeds.

Your Piranha has over-voltage protection that turns the unit off when input voltage exceeds 20 VDC. Some outboard motors do not effectively regulate the power output of the engine's alternator and can produce voltage in excess of 20 volts when running at high RPMs. The SureVolt power stabilizer from Humminbird maintains a steady voltage to the unit and solves this problem.

8. The screen begins to fade out. Images are not as sharp as normal.

Check the input voltage. The Piranha will not operate on input voltages below 8 VDC.

9. The display shows many black dots at high speeds and high sensitivity settings.

You are seeing noise or interference caused by one of several sources. Noise can be caused by other electronic devices. Turn off any nearby electronics and see if the problem goes away. Noise can also be caused by the engine. If engine noise is causing the interference, the problem will intensify at higher RPMs. Increase the engine speed with the boat stationary to isolate this cause. Propeller cavitation can appear as noise on-screen. If the transducer is mounted too close to the propeller, the turbulence generated can interfere with the sonar signal. Ensure that the transducer is mounted at least 15" (38cm) from the prop.

Humminbird One-Year Full Warranty

First year repairs (from original date of purchase) on your Piranha are absolutely free. This does not include physical damage to the unit or its accessory items. Any modification or attempt to repair the original equipment or accessories by unauthorized individuals will void the warranty. Return the warranty registration card and retain your bill of sale for warranty verification. Accessories not manufactured under the Humminbird trade name are not covered by our warranty. **The customer is responsible for shipping charges to Humminbird.** Humminbird will provide ground UPS or Parcel Post shipping back to the customer free of charge. This warranty applies to the original purchaser only.

This warranty is in lieu of all other warranties expressed or implied and no representatives or persons are authorized to provide for any other liability in connection with the sale of our products. Humminbird reserves the right to perform modifications or improvements on its products without incurring the obligation to install the changes on units previously manufactured, sold, delivered, or serviced.

THIS IS A FULL WARRANTY AS DEFINED BY THE FEDERAL WARRANTY ACT, EFFECTIVE JULY 4, 1975.

Customer Resource Center

If you have any questions, call our Humminbird Customer Resource Center Hotline:

1-334-687-0503

Throughout the U.S. and Canada, hours are Monday-Friday, 8:00 a.m. to 5:00 p.m. Central time. Or visit our web site: www.humminbird.com for Product Support and troubleshooting guides.

If after reading "Troubleshooting" you determine your unit needs factory service, please attach a description of the problem and send it with the unit with any accessories to the address below. If you are including a check, please attach it to the unit.

**Humminbird
Service Department
108 Maple Lane
Eufaula, AL 36027**

