

Installation Overview

Following are instructions for the in-dash mount installation of the PiranhaMAX control head. We encourage you to read this guide before starting the installation, so you may understand the installation requirements.

Customer Service: If you find that any items are missing from your installation kit, visit our Web site at humminbird.com or call Humminbird® Customer Service at **1-800-633-1468**.

Supplies: In addition to the hardware supplied with your In-Dash Mounting Kit, you will need a drill and 3/8" drill bit, cutting tool for cutting the dashboard material, safety glasses and dust mask, and masking tape.



NOTE: Product supplies and features are subject to change without notice.



NOTE: The illustrations in this manual may not look the same as your product, but your unit will function in the same way.

1. Plan the Mounting Location

Start by locating a suitable, flat area of the dashboard for mounting. Consider the following to find the best mounting location:

- **Stability:** The mounting area should be protected from waves, shock, vibration, and water.
- **Depth:** The control head requires a depth of at least 3 inches (76 mm).
- **Accessibility:** The location should be easily accessible for all cables to reach the ports on the back of the control head.



NOTE: If a cable is too short for your application, extension cables are available. For assistance, contact Humminbird Customer Service.

2. Cut the In-Dash Mounting Hole

To in-dash mount the PiranhaMAX control head, start by placing the components on the surfaces where you intend to install them.

1. Review the instructions, measurements, and cutting options indicated on the In-Dash Mounting Template.
 2. Tape the template to the chosen in-dash mounting location.
 3. Using the template, select the cutting method that is best for your boat:
 - Drill one entry hole away from the main cut line that is large enough to insert the blade of your cutting tool.
- OR**
- Using a 3/8" drill bit, drill the 4 corner holes (inside the main cut line) as shown on the template. Use one of the corner holes as an entry hole, or drill an additional entry hole away from the main cut line.
4. Carefully begin cutting toward the cut line, and continue cutting to the **inside of the line** around the template.

PiranhaMAX™ In-Dash Mounting Kit

532463-1_B

5. **Test the Mounting Hole:** Install the control head in the mounting hole to test the fit. Make adjustments to the mounting hole as needed. Remove the template when finished.
6. Thoroughly clean and deburr the mounting hole.

3. Install the Control Head

1. Insert and tighten the two threaded rods into the two threaded inserts located on the back side of the control head. See the illustration *Inserting the Threaded Rods*.
2. From the front side of the dashboard, insert the control head through the mounting hole.
3. Press down lightly on the control head. Confirm the control head is centered and flush against the dashboard. Make adjustments as needed.
4. From the back side of the dashboard, slide the bracket holes over the threaded rods. Install a nut onto each threaded rod and hand-tighten until it is fully secure. **Hand-tighten only!** See the illustration *Assembling the Bracket*.
5. Insert the cables into the ports on the back of the control head. The ports are keyed to prevent reverse installation, so be careful not to force the connectors into the wrong port.



CAUTION! Do NOT mount the cables where the connectors could be submerged in water or flooded. If cables are installed in a splash-prone area, it may be helpful to apply dielectric grease to the inside of the connectors to prevent corrosion. Dielectric grease can be purchased separately from a general hardware or automotive store.

Inserting the Cables

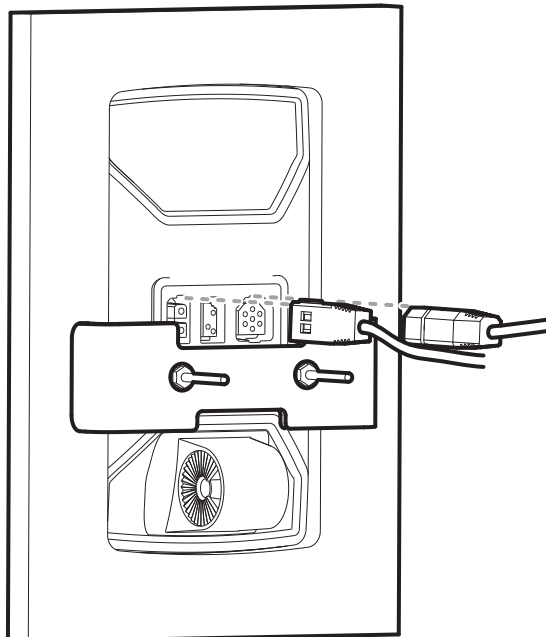

Inserting the Threaded Rods

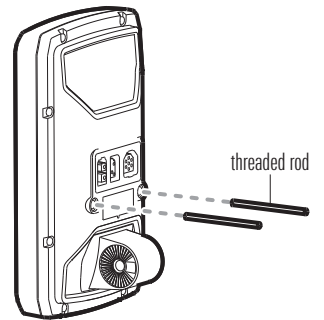

Assembling the Bracket

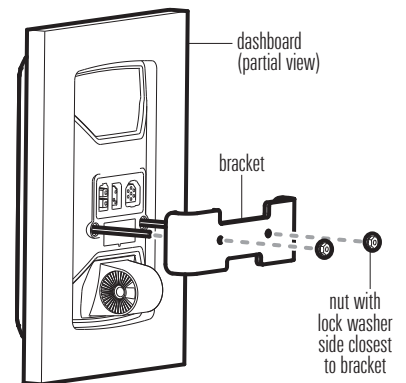

1-Year Limited Warranty

We warrant the original retail purchaser that products made by Humminbird have been manufactured free from defects in materials and workmanship. This warranty is effective for one year from the date of original retail purchase. Humminbird products found to be defective and covered by this warranty will be repaired or replaced free of charge at Humminbird's option and returned to the customer freight prepaid. Humminbird's sole responsibility under this warranty is limited to the repair or replacement of a product that has been deemed defective by Humminbird. Humminbird is not responsible for charges connected with the removal of such product or reinstallation of replaced or repaired parts; or shipping charges to the factory or authorized service center (if outside the U.S.).

This warranty does not apply to a product that has been:

- Improperly installed;
- Used in an installation other than that recommended in the product installation and operation instructions;
- Damaged or has failed because of an accident or abnormal operation;
- Repaired or modified by entities other than Humminbird.

Please retain your original receipt as a proof of the purchase date. This will be required for in-warranty service.

THIS WARRANTY IS EXPRESSLY IN LIEU OF ANY OTHER WARRANTIES, OBLIGATIONS OR LIABILITIES ON THE PART OF HUMMINBIRD AND WILL BE THE CUSTOMER'S EXCLUSIVE REMEDY, EXCEPT FOR ANY APPLICABLE IMPLIED WARRANTIES UNDER STATE LAW WHICH ARE HEREBY LIMITED IN DURATION TO ONE YEAR FROM THE DATE OF ORIGINAL PURCHASE. IN NO EVENT WILL HUMMINBIRD BE LIABLE FOR ANY INCIDENTAL OR CONSEQUENTIAL DAMAGES FOR BREACH OF ANY EXPRESS OR IMPLIED WARRANTY RELATING TO THE PRODUCTS.

Some states do not allow limitations on an implied warranty, or the exclusion of incidental or consequential damages, so the above exclusions may not apply to you. You may also have other rights, which vary from state to state.

Humminbird Service Policy

Even though you'll probably never need to take advantage of our incredible service policy, it's good to know that we back our products this confidently. We do it because you deserve the best. We will make every effort to repair your unit within three business days from the receipt of your unit at our factory. This does not include shipping time to and from our factory. Units received on Friday are typically shipped by the following Wednesday, units received Monday are typically shipped by Thursday, etc.

All repair work is performed by factory-trained technicians to meet exacting factory specifications. Factory-serviced units go through the same rigorous testing and quality control inspections as new production units.

After the original warranty period, a standard flat rate service charge will be assessed for each repair (physical damage and missing parts are not included). Any repairs made after the original warranty will be warranted for an additional 90 days after service has been performed by our factory technicians. You can contact our Customer Service or visit our Web site to verify the flat rate repair fee for your product (visit the Product Support section):

<http://www.humminbird.com>

We reserve the right to deem any product unserviceable when replacement parts are no longer available or impossible to obtain. This Service Policy is valid in the United States only. This applies only to Humminbird products returned to our factory in Eufaula, Alabama. This Service Policy is subject to change without notice.

DOMESTIC (USA) CUSTOMERS:

PLEASE DO NOT RETURN THIS PRODUCT TO STORE FOR SERVICE

For all technical issues please call **1-800-633-1468**

or visit www.humminbird.com, click **SUPPORT**.

Please reference product serial number and model number when contacting Humminbird.

PiranhaMAX™ In-Dash Mounting Kit

532463-1_B

Returning Your Unit for Service

Before sending your unit in for repair, please contact the factory, either by phone or by email, to obtain a Repair Authorization Number for your unit.



NOTE: Please do not return your Humminbird to the store for service.

Please have your product model name and serial number available before calling the factory. If you contact the factory by e-mail, please include your product model name and serial number in the e-mail, and use Request for Repair Authorization Number for your e-mail subject header. You should include your Repair Authorization Number in all subsequent communications about your unit.

For IN-WARRANTY service, complete the following steps:

- Obtain a Repair Authorization Number from Humminbird Customer Service.
- Tag product with your name, street address, phone number and your assigned Repair Authorization Number.
- Include a brief written description of the problem.
- Include a copy of your receipt (to show proof and date of purchase).
- Return product freight prepaid to Humminbird, using an insured carrier with delivery confirmation.

For OUT-OF-WARRANTY service, complete the following steps:

- Obtain a Repair Authorization Number from Humminbird Customer Service.
- Include payment in the form of credit card number and expiration date, or a money order. Please do not send cash.
- Tag product with your name, street address, phone number and your assigned Repair Authorization Number.
- Include a brief written description of the problem.
- Return product freight prepaid to Humminbird, using an insured carrier with delivery confirmation.

Contact Humminbird

Web site humminbird.com

E-mail service@humminbird.com

Telephone 1-800-633-1468

Direct Shipping Humminbird
Service Department
678 Humminbird Lane
Eufaula, AL 36027 USA



WARNING! This device should not be used as a navigational aid to prevent collision, grounding, boat damage, or personal injury. When the boat is moving, water depth may change too quickly to allow time for you to react. Always operate the boat at very slow speeds if you suspect shallow water or submerged objects.



WARNING! Disassembly and repair of this electronic unit should only be performed by authorized service personnel. Any modification of the serial number or attempt to repair the original equipment or accessories by unauthorized individuals will void the warranty.

ENVIRONMENTAL COMPLIANCE STATEMENT: It is the intention of Johnson Outdoors Marine Electronics, Inc. to be a responsible corporate citizen, operating in compliance with known and applicable environmental regulations, and a good neighbor in the communities where we make or sell our products.

WEEE DIRECTIVE: EU Directive 2002/96/EC "Waste of Electrical and Electronic Equipment Directive (WEEE)" impacts most distributors, sellers, and manufacturers of consumer electronics in the European Union. The WEEE Directive requires the producer of consumer electronics to take responsibility for the management of waste from their products to achieve environmentally responsible disposal during the product life cycle.

WEEE compliance may not be required in your location for electrical & electronic equipment (EEE), nor may it be required for EEE designed and intended as fixed or temporary installation in transportation vehicles such as automobiles, aircraft, and boats. In some European Union member states, these vehicles are considered outside of the scope of the Directive, and EEE for those applications can be considered excluded from the WEEE Directive requirement.



This symbol (WEEE wheelie bin) on product indicates the product must not be disposed of with other household refuse. It must be disposed of and collected for recycling and recovery of waste EEE. Johnson Outdoors Marine Electronics, Inc. will mark all EEE products in accordance with the WEEE Directive. It is our goal to comply in the collection, treatment, recovery, and environmentally sound disposal of those products; however, these requirements do vary within European Union member states. For more information about where you should dispose of your waste equipment for recycling and recovery and/or your European Union member state requirements, please contact your dealer or distributor from which your product was purchased.