



MINN KOTA
ULTERRA

ULTERRA™

BOW-MOUNT TROLLING MOTOR

Owner's Manual

INTRODUCTION

THANK YOU

Thank you for choosing Minn Kota. We believe that you should spend more time fishing and less time positioning your boat. That's why we build the smartest, toughest, most intuitive trolling motors on the water. Every aspect of a Minn Kota trolling motor is thought out and rethought until it's good enough to bear our name. Countless hours of research and testing provide you the Minn Kota advantage that can truly take you "Anywhere. Anytime." We don't believe in shortcuts. We are Minn Kota. And we are never done helping you catch more fish.

REGISTRATION

Remember to keep your receipt and immediately register your trolling motor. A registration card is included with your motor or you can complete registration on our website at minnkotamotors.com.

SERIAL NUMBER

Your Minn Kota 11-character serial number is very important. It helps to determine the specific model and year of manufacture. When contacting Consumer Service or registering your product, you will need to know your product's serial number. We recommend that you write the serial number down so that you have it available for future reference.

NOTICE: The serial number on your Ulterra is located inside the mount near the motor rests.

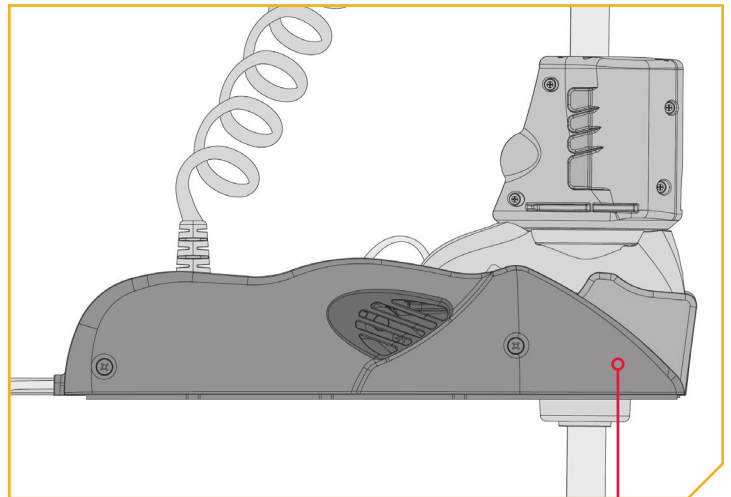

MOTOR INFORMATION (For Consumer Reference Only)

Model: _____

Serial Number: _____

Purchase Date: _____

Store Where Purchased: _____

NOTICE: Do not return your Minn Kota motor to your retailer. Your retailer is not authorized to repair or replace this unit. You may obtain service by: calling Minn Kota at (800) 227-6433; returning your motor to the Minn Kota Factory Service Center; sending or taking your motor to any Minn Kota authorized service center. A list of authorized service centers is available on our website, at minnkotamotors.com. Please include proof of purchase, serial number and purchase date for warranty service with any of the above options.

TABLE OF CONTENTS

SAFETY CONSIDERATIONS	4
WARRANTY	5
KNOW YOUR BOAT	6
FEATURES	7
INSTALLATION	8
Installing the Ulterra	9
Identifying Trolling Motor Features by their Associated Cables	16
Routing Connection Cables	17
Feature Overview and Connecting the Cables	18
Built-in MEGA Side Imaging	18
Built-in MEGA Down Imaging	20
Universdal Sonar	22
i-Pilot Link	24
BATTERY & WIRING INSTALLATION	26
Boat Rigging & Product Installation	26
Conductor Gauge and Circuit Breaker Sizing Table	26
Selecting the Correct Batteries	27
Additional Considerations	27
Connecting the Batteries in Series	28
MOTOR WIRING DIAGRAM	30
USING & ADJUSTING THE MOTOR	31
Mount Features	31
Quick Stow & Deploy	33
Installing an External Transducer	38
Changing the Prop Orientation	39
Adjusting the Lift Belt	42
Greasing the Latch Pin and Power Tilt Motor Shaft	42
Stowing from the Ulterra Motor	43
Trim/Stow Reset Procedure	44
Manually Stowing the Ulterra	45
USING THE FOOT PEDAL	49
Controlling Speed & Steering with the Foot Pedal	49
Modes	49
Foot Pedal Operation	49
Stowing and Deploying the Motor with the Foot Pedal	52
Adjusting the Depth of the Motor (Trim) with the Foot Pedal	53
SERVICE & MAINTENANCE	54
Propeller Replacement	54
General Maintenance	55
Troubleshooting	55
Advanced Troubleshooting	57
For Further Troubleshooting and Repair	64
COMPLIANCE STATEMENTS	65
PARTS DIAGRAM & PARTS LIST	67

SAFETY CONSIDERATIONS

Please thoroughly read the user manual. Follow all instructions and heed all safety and cautionary notices. Use of this motor is only permitted for persons that have read and understood these user instructions. Minors may use this motor only under adult supervision.

WARNING

You are responsible for the safe and prudent operation of your vessel. We have designed your Minn Kota product to be an accurate and reliable tool that will enhance boat operation and improve your ability to catch fish. This product does not relieve you from the responsibility for safe operation of your boat. You must avoid hazards to navigation and always maintain a permanent watch so you can respond to situations as they develop. You must always be prepared to regain manual control of your boat. Learn to operate your Minn Kota product in an area free from hazards and obstacles.

WARNING

Never run the motor out of the water, as this may result in injuries from the rotating propeller. The motor should be disconnected from the power source when it is not in use or is off the water. When connecting the power-supply cables of the motor to the battery, ensure that they are not kinked or subject to chafe and route them in such a way that persons cannot trip over them. Before using the motor make sure that the insulation of the power cables is not damaged. Disregarding these safety precautions may result in electric shorts of battery(s) and/or motor. Always disconnect motor from battery(s) before cleaning or checking the propeller. Avoid submerging the complete motor as water may enter the lower unit through control head and shaft. If the motor is used while water is present in the lower unit considerable damage to the motor can occur. This damage will not be covered by warranty.

WARNING

Take care that neither you nor other persons approach the turning propeller too closely, neither with body parts nor with objects. The motor is powerful and may endanger or injure you or others. While the motor is running watch out for persons swimming and for floating objects. Persons who lack the ability to run the motor or whose reactions are impaired by alcohol, drugs, medication, or other substances are not permitted to use this motor. This motor is not suitable for use in strong currents. The constant noise pressure level of the motor during use is less than 70dB(A). The overall vibration level does not exceed 2,5 m/sec².

WARNING

When stowing or deploying the motor, keep fingers clear of all hinge and pivot points and all moving parts. In the event of unexpected operation, remove power leads from the battery.

WARNING

It is recommended to only use Johnson Outdoors approved accessories with your Minn Kota motor. Using non-approved accessories including to mount or control your motor may cause damage, unexpected motor operation and injury. Be sure to use the product and approved accessories, including remotes, safely and in the manner directed to avoid accidental or unexpected motor operation. Keep all factory installed parts in place including motor and accessory covers, enclosures and guards.

WARRANTY

WARRANTY ON MINN KOTA FRESHWATER TROLLING MOTORS

Johnson Outdoors Marine Electronics, Inc. ("JOME") extends the following limited warranty to the original retail purchaser only. Warranty coverage is not transferable.

Minn Kota Limited Two-Year Warranty on the Entire Product

JOME warrants to the original retail purchaser only that the purchaser's new Minn Kota freshwater trolling motor will be materially free from defects in materials and workmanship appearing within two (2) years after the date of purchase. JOME will (at its option) either repair or replace, free of charge, any parts found by JOME to be defective during the term of this warranty. Such repair, or replacement shall be the sole and exclusive liability of JOME and the sole and exclusive remedy of the purchaser for breach of this warranty.

Minn Kota Limited Lifetime Warranty on Composite Shaft

JOME warrants to the original retail purchaser only that the composite shaft of the purchaser's Minn Kota trolling motor will be materially free from defects in materials and workmanship appearing within the original purchaser's lifetime. JOME will provide a new composite shaft, free of charge, to replace any composite shaft found by JOME to be defective during the term of this warranty. Providing a new composite shaft shall be the sole and exclusive liability of JOME and the sole and exclusive remedy of the purchaser for breach of this warranty; **and purchaser shall be responsible for installing, or for the cost of labor to install, any new composite shaft provided by JOME.**

Exclusions & Limitations

This limited warranty does not apply to products that have been used in saltwater or brackish water, commercially or for rental purposes. This limited warranty does not cover normal wear and tear, blemishes that do not affect the operation of the product, or damage caused by accidents, abuse, alteration, modification, shipping damages, negligence of the user or misuse, improper or insufficient care or maintenance. **DAMAGE CAUSED BY THE USE OF OTHER REPLACEMENT PARTS NOT MEETING THE DESIGN SPECIFICATIONS OF THE ORIGINAL PARTS WILL NOT BE COVERED BY THIS LIMITED WARRANTY.** The cost of normal maintenance or replacement parts which are not in breach of the limited warranty are the responsibility of the purchaser. Prior to using products, the purchaser shall determine the suitability of the products for the intended use and assumes all related risk and liability. Any assistance JOME provides to or procures for the purchaser outside the terms, limitations or exclusions of this limited warranty will not constitute a waiver of the terms, limitations or exclusions, nor will such assistance extend or revive the warranty. JOME will not reimburse the purchaser for any expenses incurred by the purchaser in repairing, correcting or replacing any defective products or parts, except those incurred with JOME's prior written permission. **JOME'S AGGREGATE LIABILITY WITH RESPECT TO COVERED PRODUCTS IS LIMITED TO AN AMOUNT EQUAL TO THE PURCHASER'S ORIGINAL PURCHASE PRICE PAID FOR SUCH PRODUCT.**

Minn Kota Service Information

To obtain warranty service in the U.S., the product believed to be defective, and proof of original purchase (including the date of purchase), must be presented to a Minn Kota Authorized Service Center or to Minn Kota's factory service center in Mankato, MN. Any charges incurred for service calls, transportation or shipping/freight to/from the Minn Kota Authorized Service Center or factory, labor to haul out, remove, re-install or re-rig products removed for warranty service, or any other similar items are the sole and exclusive responsibility of the purchaser. Products purchased outside of the U.S. must be returned prepaid with proof of purchase (including the date of purchase and serial number) to any Authorized Minn Kota Service Center in the country of purchase. Warranty service can be arranged by contacting a Minn Kota Authorized Service Center or by contacting the factory at 1-800-227-6433 or email service@minnkotamotors.com. **Products repaired or replaced will be warranted for the remainder of the original warranty period [or for 90 days from the date of repair or replacement, whichever is longer]. For any product that is returned for warranty service that JOME finds to be not covered by or not in breach of this limited warranty, there will be a billing for services rendered at the prevailing posted labor rate and for a minimum of at least one hour.**

NOTICE: Do not return your Minn Kota product to your retailer. Your retailer is not authorized to repair or replace products.

NOTICE: THERE ARE NO EXPRESS WARRANTIES OTHER THAN THESE LIMITED WARRANTIES. IN NO EVENT SHALL ANY IMPLIED WARRANTIES INCLUDING ANY IMPLIED WARRANTIES OF MERCHANTABILITY OR FITNESS FOR PARTICULAR PURPOSE, EXTEND BEYOND THE DURATION OF THE RELEVANT EXPRESS LIMITED WARRANTY. IN NO EVENT SHALL JOME BE LIABLE FOR PUNITIVE, INDIRECT, INCIDENTAL, CONSEQUENTIAL OR SPECIAL DAMAGES. Without limiting the foregoing, JOME assumes no responsibility for loss of use of product, loss of time, inconvenience or other damage.

Some states do not allow limitations on how long an implied warranty lasts or the exclusion or limitation of incidental or consequential damages, so the above limitations and/or exclusions may not apply to you. This warranty gives you specific legal rights and you may also have other legal rights which vary from state to state.

KNOW YOUR BOAT

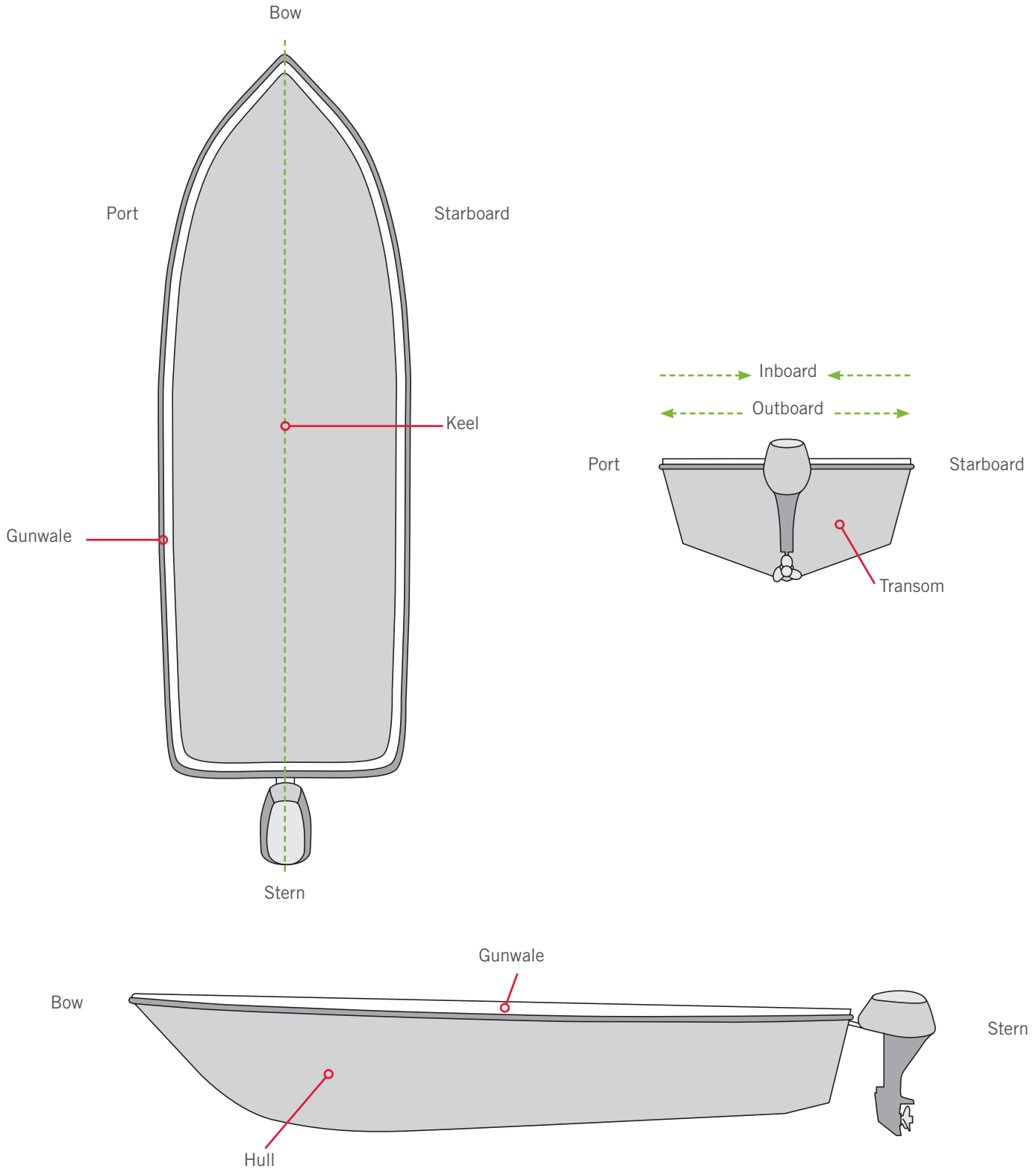

FEATURES

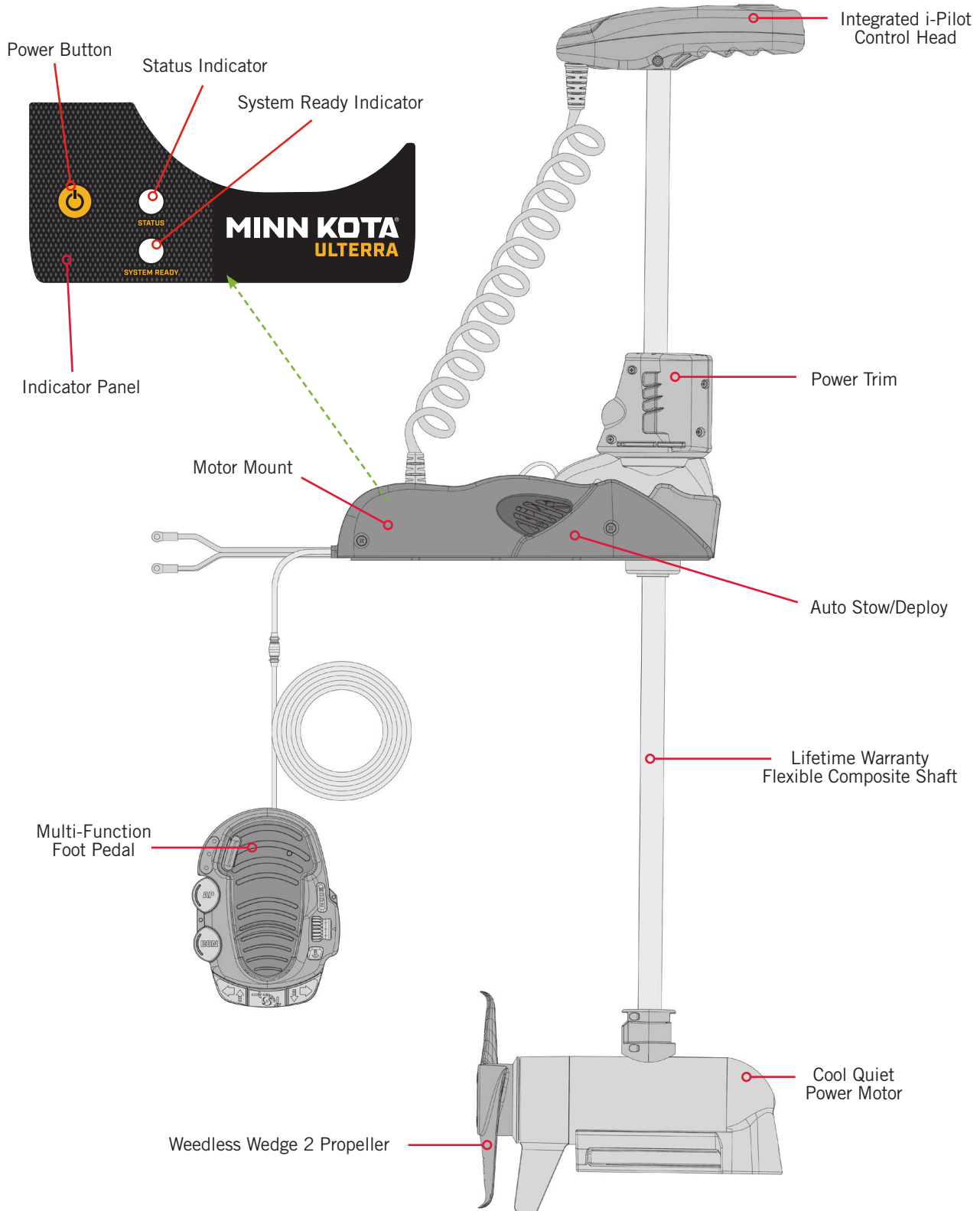

NOTICE: Specifications subject to change without notice. This diagram is for reference only and may differ from your actual motor.

INSTALLATION

INSTALLING THE ULTERRA

Your new Ulterra comes with everything you'll need to directly install it to the boat. This motor can be directly mounted to the boat or it may be coupled with a Minn Kota quick release bracket for ease of mounting and removal. For installation with a quick release bracket, refer to the installation instructions provided with the bracket. For installation with a quick release bracket, please visit minnkotamotors.com. To install the motor directly to the boat, please follow the instructions provided in this manual. Please review the parts list, mounting considerations and tools needed for installation prior to getting started. For additional product support and to locate your nearest dealer, please visit minnkotamotors.com.

INSTALLATION PARTS LIST

Item / Assembly	Part #	Description	Qty.
1	✘	MOTOR ASSEMBLY	1
AA	2994859	BAG ASY-TERROVA/V2,RUB.BUMPERS	1
2	2325110	PAD, FOOTPEDAL	5
BB	2994917	BAG ASSY, ULTERRA MTG HARDWARE	1
3	2203430	SCREW-1/4-20 X 2.0 HHCS SS	6
4	2203431	SCREW-1/4-20 X 0.5 HHCS SS	6
5	2201725	WASHER-CLIPPED, 1/4", 1.00" OD	6
6	2261713	WASHER-1/4 FLAT 18-8 SS	6
7	2263103	NUT-1/4-20 NYLOCK SS	6
8	2301720	WASHER-MOUNTING - RUBBER	6
9	2203801	STRAP, HOLD DOWN	1
10	2994075 ◆	REMOTE ASSEMBLY, iPILOT	1
11	2994076 ●	REMOTE ASSEMBLY LINK TOUCHSCREEN	1
▲	2397106 ◆	MANUAL, QUICK REF., iPILOT 1.6	1
▲	2397107 ●	MANUAL-QUICK REF., iPILOT 3.0	1
12	2390800 ◆●	LANYARD, REMOTE W/ CARABINER	1
13	2373241 ●	CABLE, USB REMOTE CHARGER LINK	1
14	2375901 ●	ADAPTER, USB DC POWER LINK	1
15	2996400 ◆●	HEADING SENSOR ASSEMBLY	1
16	490389-1 ●	CABLE, ETH (M12-M-M12-F, 30'	1
17	2211415 +	CABLE-EXTENSION, PD/AP 110" *PRE-INSTALLED*	1
	490507-1 →	CABLE, ADP-INT MDI 14 M12-120" *PRE-INSTALLED*	1
	490516-3 *	CABLE, ADP-INT MSI 14 M12-156" *PRE-INSTALLED*	1
CC	1378132	80# THRUST PROP KIT	1
DD	1378160	112# THRUST PROP KIT	1
18	2262658	PIN-DRIVE 1" X 3/16" S/S	1
19	2091701	WASHER-PROP (LARGE) MAX101	1
20	2093101	NUT-PROP,NYLOC,LG,MX101 3/8 SS	1
	2331160	PROP-WW2 (4") w/ADP.RING	1
21	2341160	PROP-WW2 (4.5) w/ADP.RING	1
	▲	2207113	MANUAL, INSTALL GUIDE, ULTERRA
22	2994741	FOOT PEDAL ASSY, ULTERRA	1

- ▲ Not shown on Parts Diagram.
- ✘ This part is included in an assembly and cannot be ordered individually.
- ◆ Only available with models factory installed with i-Pilot.
- Only available with models factory installed with i-Pilot Link.
- + Only available with models factory installed with Universal Sonar.
- Only available with models factory installed with Built-in MEGA Down Imaging.
- * Only available with models factory installed with Built-in MEGA Side Imaging.

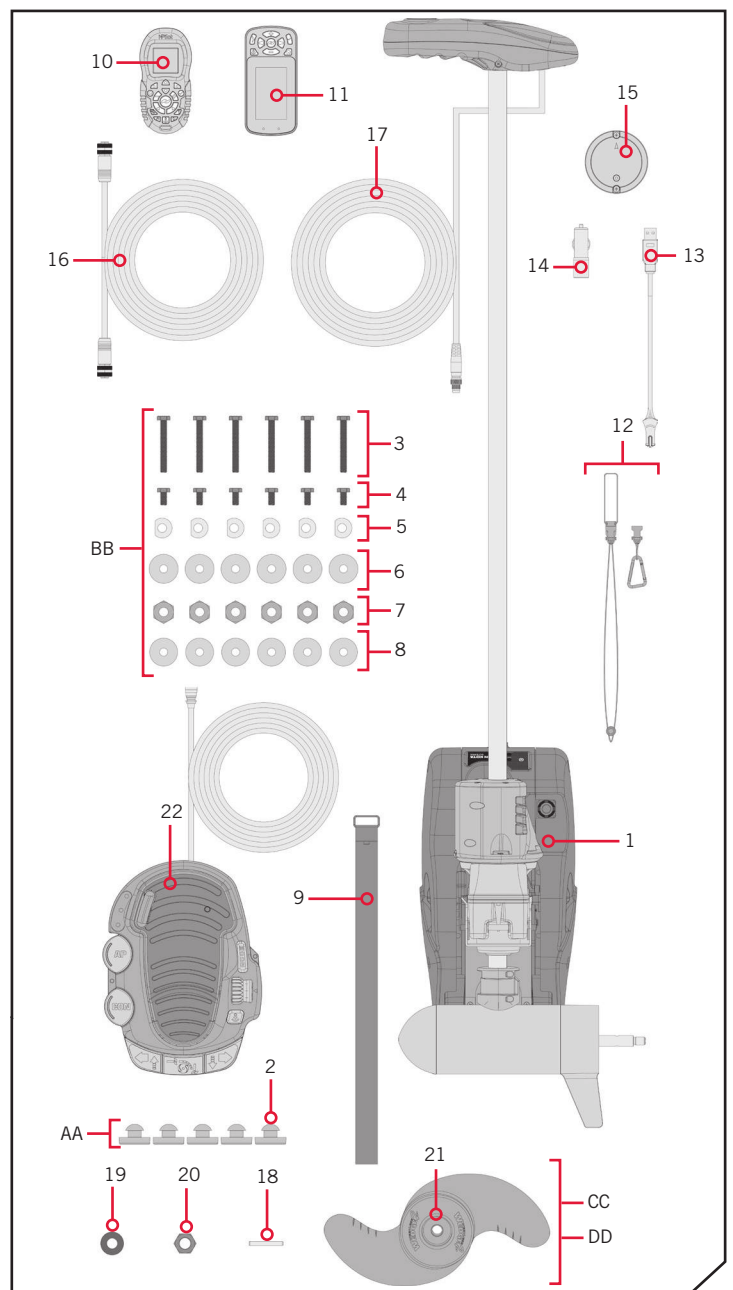

INSTALLING THE ULTERRA

MOUNTING CONSIDERATIONS

It is recommended that the motor be mounted as close to the keel or centerline of the boat as possible. Make sure the area under the mounting location is clear to drill holes and install nuts and washers. Make sure the motor rest is positioned far enough beyond the edge of the boat. The motor must not encounter any obstructions as it is lowered into the water or raised into the boat when stowed and deployed. Consider a quick release or adapter bracket with the installation of your motor. To view a list of accessories, please visit minnkotamotors.com.



View accessories available for your trolling motor at minnkotamotors.com.

TOOLS AND RESOURCES REQUIRED

- #2 Phillips Screwdriver
- #3 Phillips Screwdriver
- Drill
- 9/32" Drill Bit
- A person to help with installation

INSTALLATION

INSTALLING THE ULTERRA

1. a. Place the Motor on an elevated, level surface such as a workbench or the tailgate of a pickup. The motor, as removed from the box, should be in the stowed position.
b. Remove the four sideplate screws using a #3 or #2 Phillips screwdriver. Two of these screws will be located on each side of the Motor Mount.

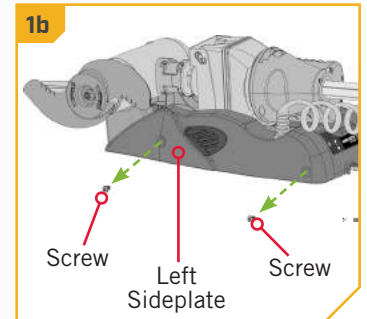
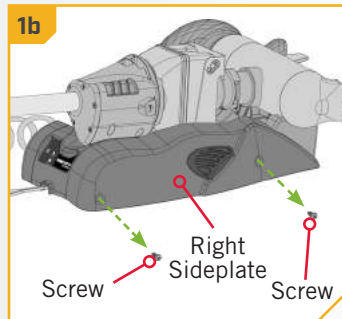
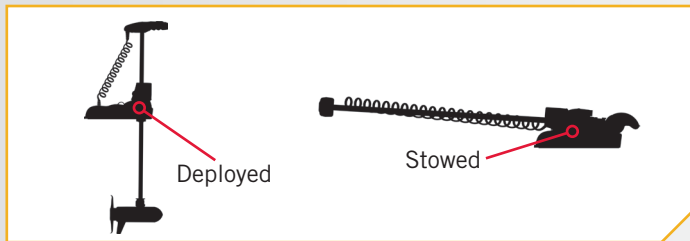

NOTICE: This motor weighs approximately 70 lbs. We recommend having a second person help with the installation.

2. c. Remove the Right Sideplate to access the Mounting Slots.
d. Remove the Left Sideplate to access the Mounting Holes.

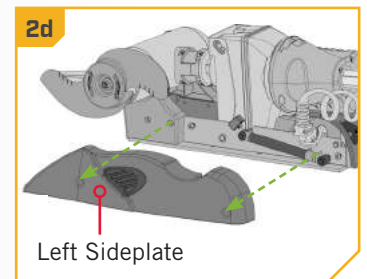
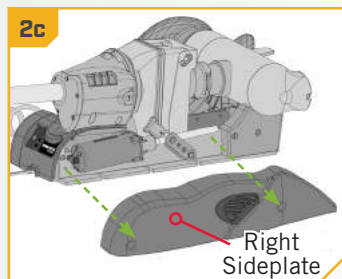

INSTALLING THE ULTERRA

3

- e. Under the Left Sideplate, the Extension Damper obstructs access to the left front Mounting Hole.
- f. Using a small Screw Driver, remove the two 5/16" E-clips holding the Extension Damper in place. Once the E-clips are removed, slide the Extension Damper off the Damper Pins to expose the left rear Mounting Hole. Set the two E-clips and Extension Damper in a safe place so they are not misplaced before they are reassembled later in the installation.

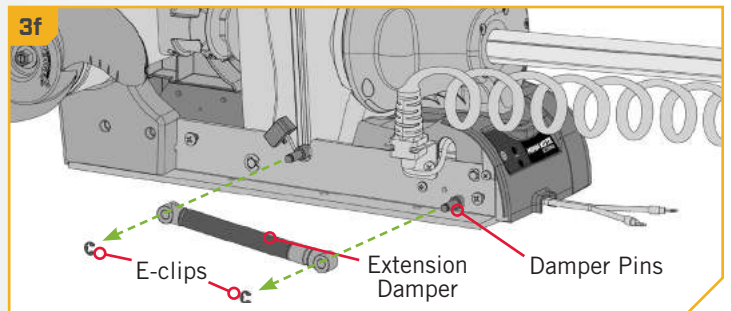
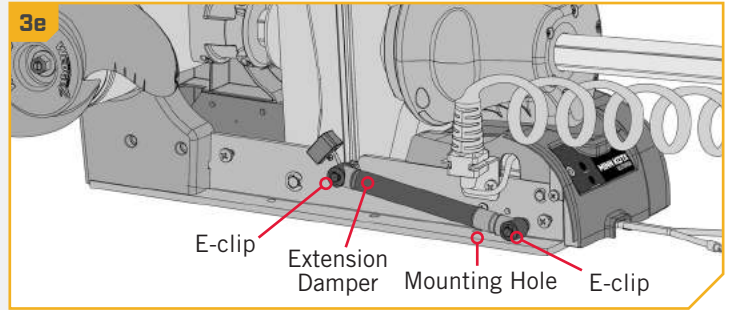

⚠ WARNING

Do not deploy the motor until it is fully mounted to the boat. Illustrations are for reference only. Deploying your motor before it is mounted to the boat may cause injury.

4

- g. Make sure the Power Cables from the battery are disconnected, or that the breaker, if equipped, is "off".

⚠ WARNING

Make sure the motor is mounted on a level surface and is not connected to a power source.

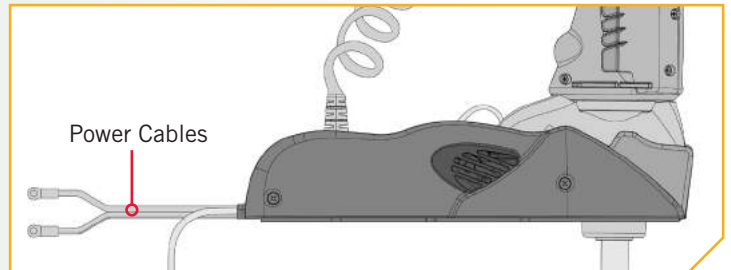

5

- h. Place the motor on the bow of the boat. Place the motor as close to the centerline or keel of the boat as possible. The motor can be installed on either the Port or Starboard side of the boat based on personal preference. Reviewing the mounting considerations at the beginning of the installation section.

NOTICE: The Emergency Strap (Item #9) is used for Manually Stowing the Ultrerra. The Emergency Strap is not secured during installation. Store it on your boat in the event that you would need to manually stow the motor. To learn how, please refer to the "Manually Stowing the Ultrerra" section of the Owner's Manual.

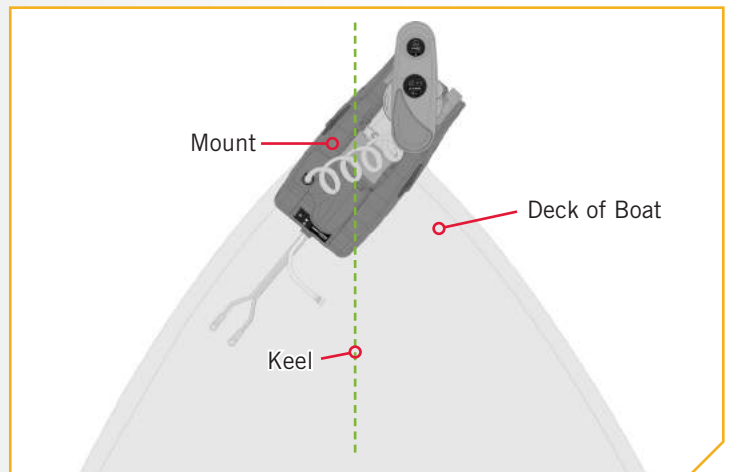

6

ITEM(S) NEEDED

-  #8 x 6

WARNING

Do not deploy the motor until it is fully mounted to the boat. Illustrations are for reference only. Deploying your motor before it is mounted to the boat may cause injury.

- i. Make sure the slot on the underside of the Base Extrusion is aligned with the outermost part of the gunwale of the boat. This will ensure that the Shaft has a minimum clearance of 1-1/2" when it is deployed. The lower unit when stowed and deployed must not encounter any obstructions.
- j. Check to be sure that the Motor Mount is level. Use the Rubber Washers (Item #8) provided to create a level surface if necessary.

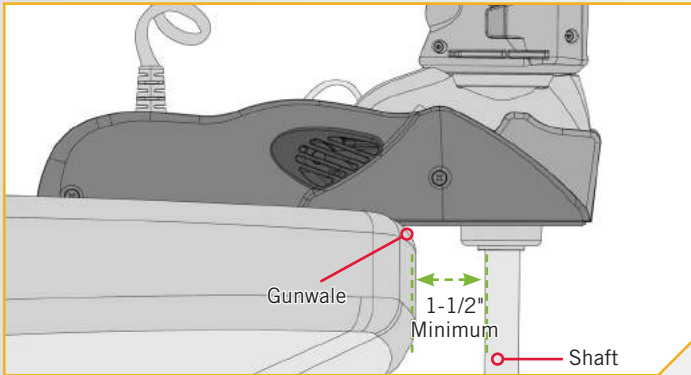

CAUTION

Failure to allow 1-1/2" of clearance of the Shaft when mounting may cause failures when the motor stows and deploys. Follow recommended mounting considerations to avoid obstructions when operating the motor.

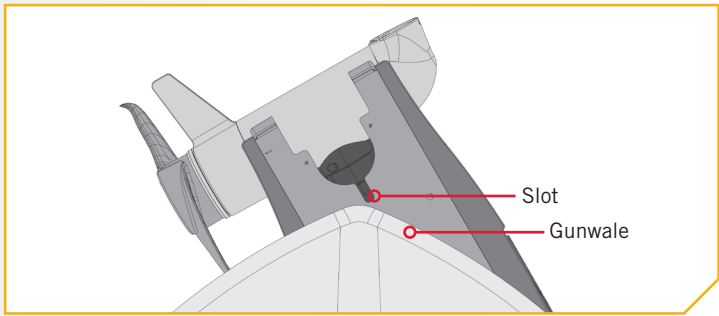
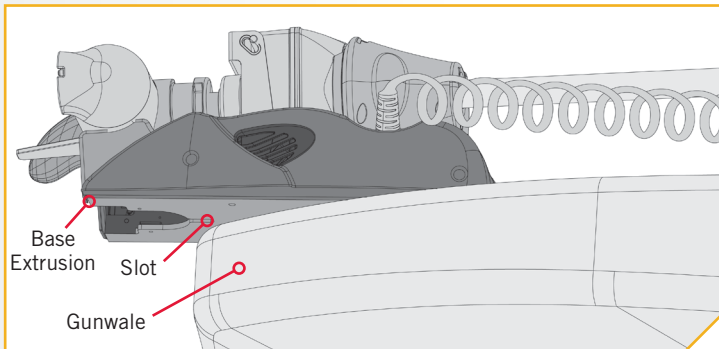

7

- k. It is recommended to mark at least 4 of the 6 holes in the Base Extrusion to have a minimum of two bolts on each side that are located the farthest apart. Ideal installation would allow for 6 bolts to be used, with a minimum of 4.
- l. Make sure the area under the mounting location is clear to drill holes and install nuts and washers. Drill through the marked holes using a 9/32" drill bit.

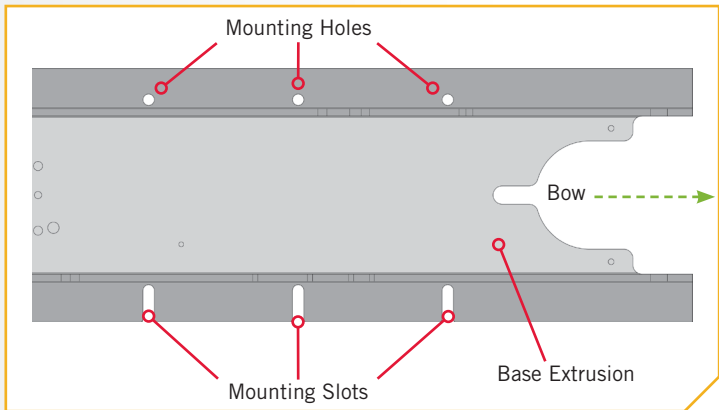

INSTALLING THE ULTERRA

8

m. Mount the motor to the boat using the provided hardware. Place the installation hardware for the side of the Motor where the Power Tilt is located first. This is the opposite side of the Base Extrusion from where the Extension Damper was removed. The base of the Motor where the Power Tilt is located has Mounting Slots and the side where the Extension Damper is located has Mounting Holes.

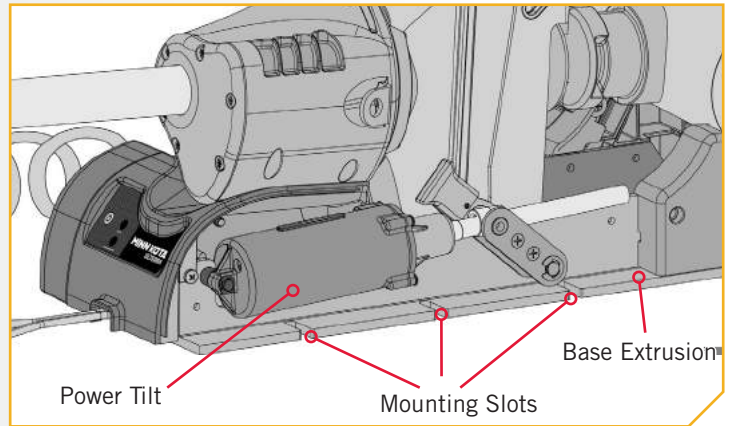

9

ITEM(S) NEEDED



#6 x 3



#3 x 3



#5 x 3



#7 x 3



#4 x 3

NOTICE: To prevent seizing of the stainless steel hardware, do not use high speed installation tools. Wetting the screws or applying an anti-seize may help prevent seizing.

n. **If installing with a Quick Release Bracket,** install the motor with the Hex Head Bolts (Item #4) and Clipped Washers (Item #5). Orientate the Clipped Washers so that the flat side of the washer is towards the Base Extrusion. The Bolt should pass through the Clipped Washer and into a Quick Release Bracket. Leave at least 1/4" space between the Hex Head Bolt and Clipped Washer in order to slide the Base Extrusion under the Clipped Washer and into place.

NOTICE: The Long Bolts, Flat Washers and Nylock Nut are not used when installing the Ulterra with a Quick Release Bracket.

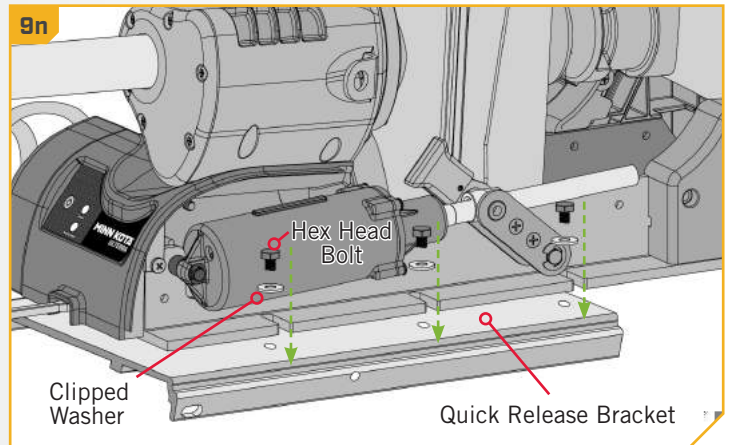

CAUTION

Use extra care to avoid pinching and damaging the sensor wires that run along side of the Base Extrusion when installing and tightening the motor mounting bolts.

10

o. **If installing directly to the boat deck**, install the motor with the Long Bolts (Item #3), Clipped Washer (Item #5), Flat Washer (Item #6) and Nylock Nut (Item #7). Orientate the Clipped Washers so that the flat side of the washer is towards the Base Extrusion. The Bolt should pass through the Clipped Washer, the Rubber Washer and then through the Boat Deck. The Bolt should be secured by first adding the Flat Washer (Item #6) to the Bolt and securing with a Nylock Nut (Item #7). Leave at least 1/4" space between the Hex Head Bolt and Clipped Washer and the deck of the boat. This will leave enough space to slide the Base Extrusion between the Clipped Washer and Rubber Washer and into place.

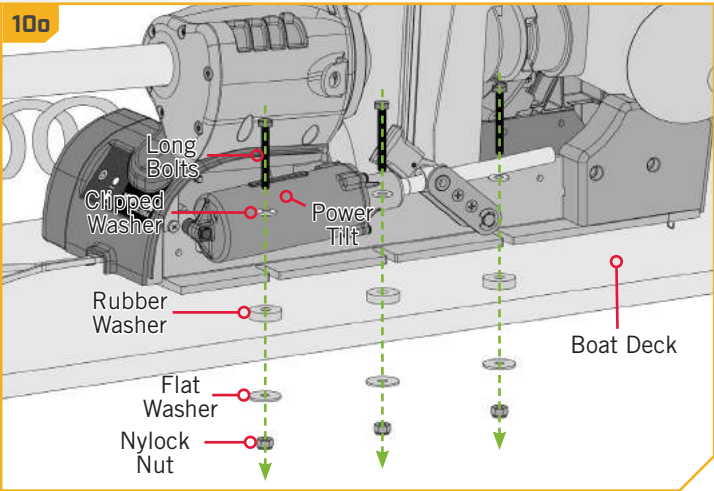

NOTICE: The Short Bolts are not used when installing the Ulterra directly to the boat.

11

- p. Slide the Base Extrusion into place under the Bolts that were just installed.
- q. **If installing with a Quick Release Bracket**, the Base Extrusion should slide between the Quick Release Bracket and the Clipped Washers. Hold the Clipped Washers up on the Hex Head Bolt, so the Clipped Washer will sit on top of the Base Extrusion.
- r. **If installing directly to the boat deck**, the Base Extrusion should slide between the Clipped Washer and the Rubber Washer. Hold the Clipped Washers up on the Long Bolt, so the Clipped Washer will sit on top of the Base Extrusion.

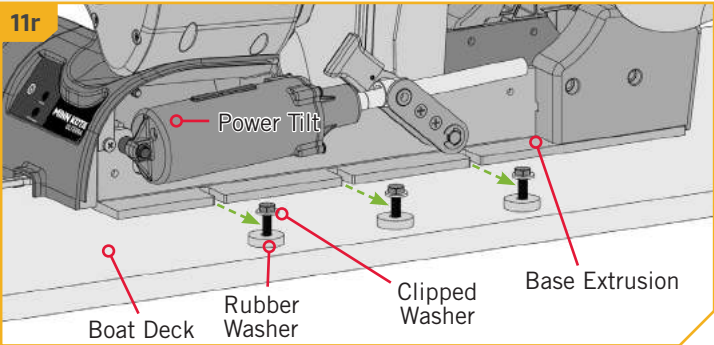
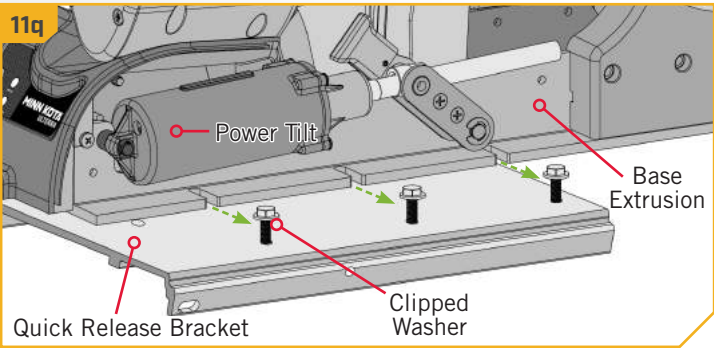

INSTALLING THE ULTERRA

12

ITEM(S) NEEDED



#6 x 3



#3 x 3



#5 x 3



#7 x 3



#4 x 3

NOTICE: To prevent seizing of the stainless steel hardware, do not use high speed installation tools. Wetting the screws or applying an anti-seize may help prevent seizing.

- s. Place the hardware on the Damper side of the mount into the Mounting Holes to secure the Base Extrusion.
- t. **If installing with a Quick Release Bracket,** install the motor with the Hex Head Bolts (Item #4) and Clipped Washers (Item #5). Orientate the Clipped Washers so that the flat side of the washer is towards the Base Extrusion. The Bolt should pass through the Clipped Washer, Base Extrusion and into a Quick Release Bracket.

NOTICE: The Long Bolts, Flat Washers and Nylock Nut are not used when installing the Ultrerra with a Quick Release Bracket.

- u. **If installing directly to the boat deck,** install the motor with the Long Bolts (Item #3), Clipped Washer (Item #5), Flat Washer (Item #6) and Nylock Nut (Item #7). Orientate the Clipped Washers so that the flat side of the washer is towards the Base Extrusion. The Bolt should pass through the Clipped Washer, the Base Extrusion, the Rubber Washer and then through the Boat Deck. The Bolt should be secured by first adding the Flat Washer (Item #6) and then securing with a Nylock Nut (Item #7).

NOTICE: The Short Bolts are not used when installing the Ultrerra directly to the boat.

CAUTION

Use extra care to avoid pinching and damaging the sensor wires that run along side of the Base Extrusion when installing and tightening the motor mounting bolts.

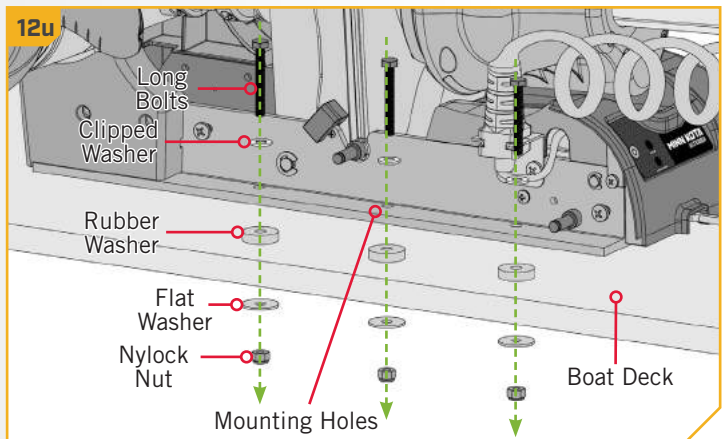
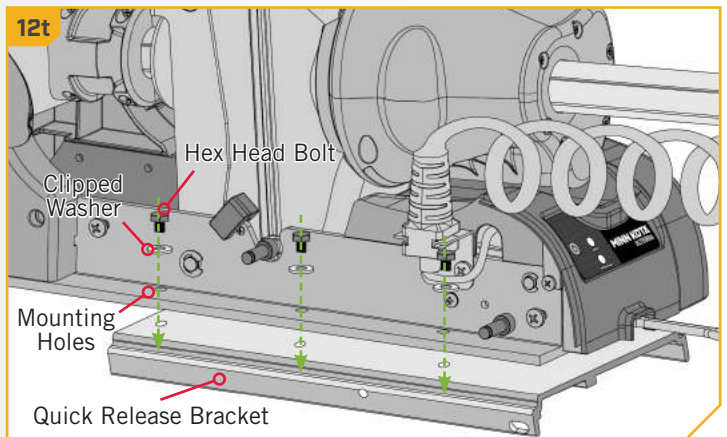
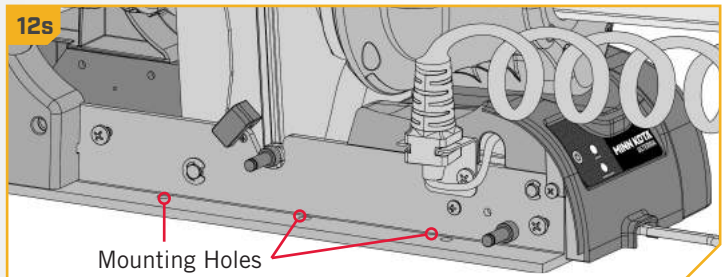

INSTALLING THE ULTERRA

13

- v. At this point in the installation process the Motor should be secured to the deck of the boat, and the Motor can now be reassembled. The Extension Damper can be slid back in place on the Damper Pins. This should be done so the shaft on the Damper is pointing inboard. Reinstall the two 5/16" E-clips.

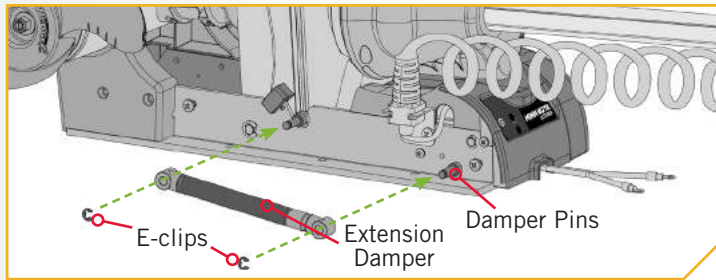

14

- w. Replace the Right Sideplate.
- x. Replace the Left Sideplate.
- y. Replace the four sideplate Screws using a #2 or #3 Phillips Screw Driver.

14w

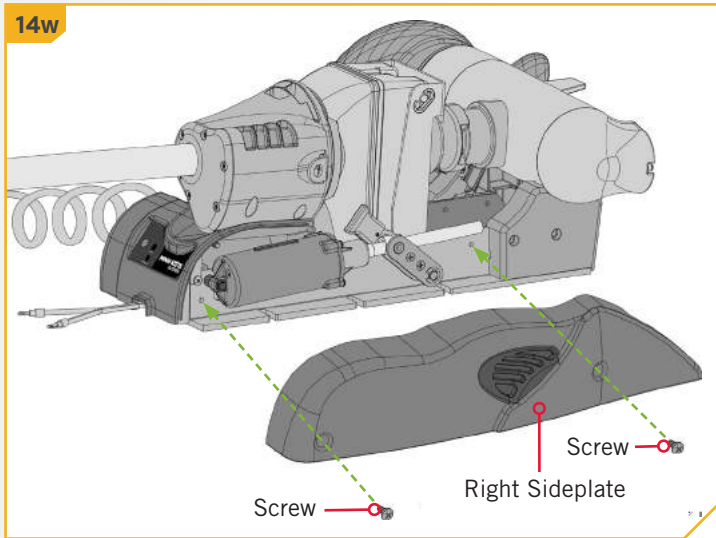

14x

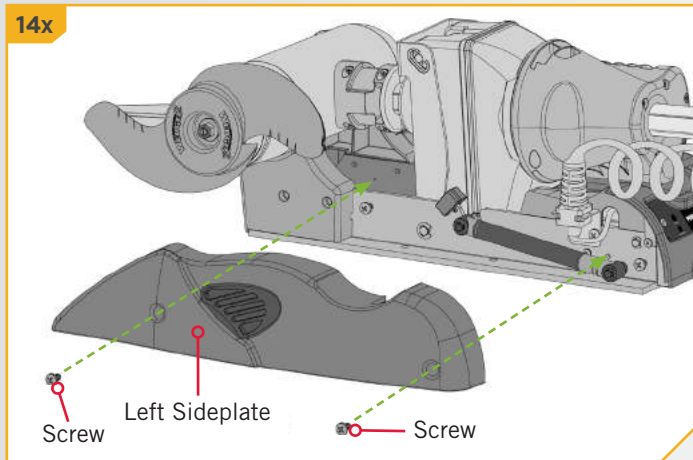

15

ITEM(S) NEEDED

 **#18 x 4**



#EE x 1

- z. Take the Foot Pedal (Item #EE) and turn it over. Put a Foot Pedal Pad (Item #18) in each of the pad locations.

NOTICE: The pads are recommended when using the Foot Pedal on non-carpeted surfaces.

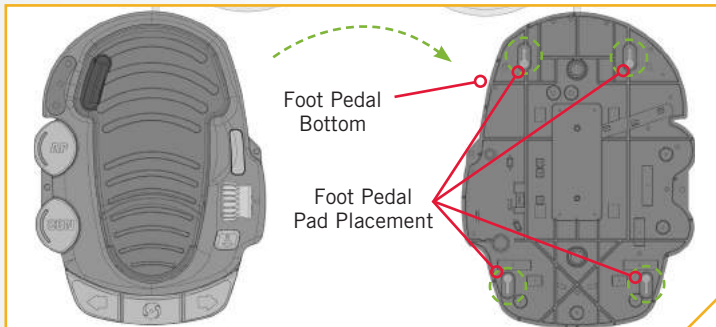

IDENTIFYING TROLLING MOTOR FEATURES BY THEIR ASSOCIATED CABLES

IDENTIFYING TROLLING MOTOR FEATURES AND THEIR ASSOCIATED CABLES

Your trolling motor may be pre-installed with Built-In MEGA Side Imaging, Built-In MEGA Down Imaging OR Universal Sonar, and may include i-Pilot Link. All of these features require cables to be connected to an output device. These connections are present on the trolling motor and have cables that exit below the Control Head. To better identify cables present, refer to the diagrams below that detail what the Built-In MEGA Side Imaging, Built-In MEGA Down Imaging, Universal Sonar and i-Pilot Link cable connectors look like.

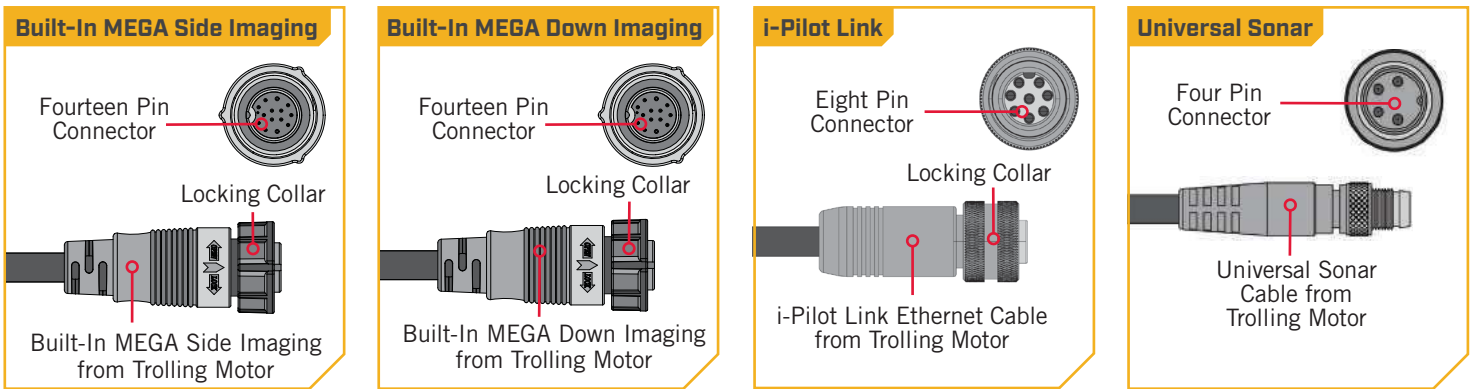

If **one** connection below the Control Head is present, the motor may be equipped with:

1. i-Pilot and Universal Sonar,
2. i-Pilot and Built-in MEGA Down Imaging,
3. ONLY Universal Sonar, or
4. ONLY Built-in MEGA Down Imaging.

If **two** connections below the Control Head are present, the motor may be equipped with either:

1. i-Pilot Link and Universal Sonar,
2. i-Pilot Link and Built-in MEGA Down Imaging or
3. i-Pilot Link and Built-in MEGA Side Imaging

NOTICE: The i-Pilot system does not have an external wired connection. On current models, Built-in MEGA Side Imaging is installed with i-Pilot Link. To further help determine your motor type, motors with Built-in MEGA Down Imaging and Built-in MEGA Side Imaging will have different geometry in the lower unit.

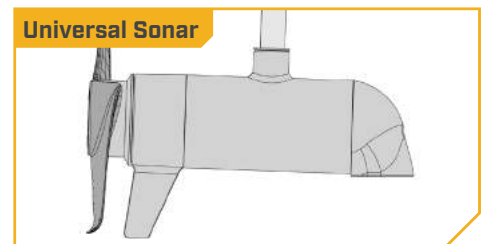
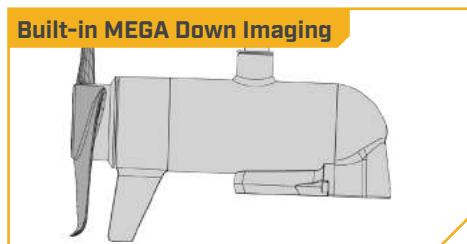
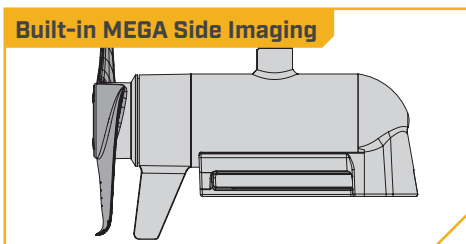
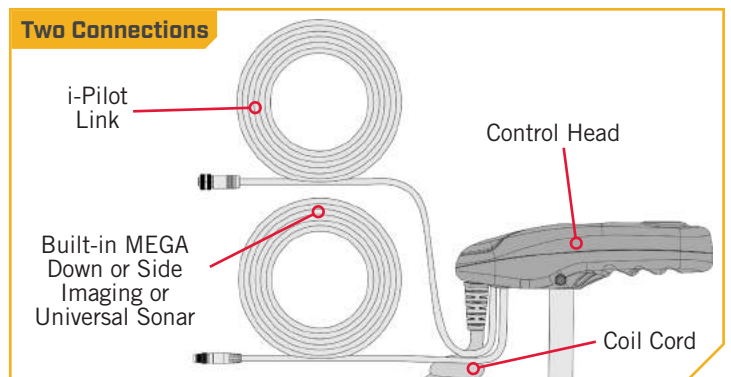
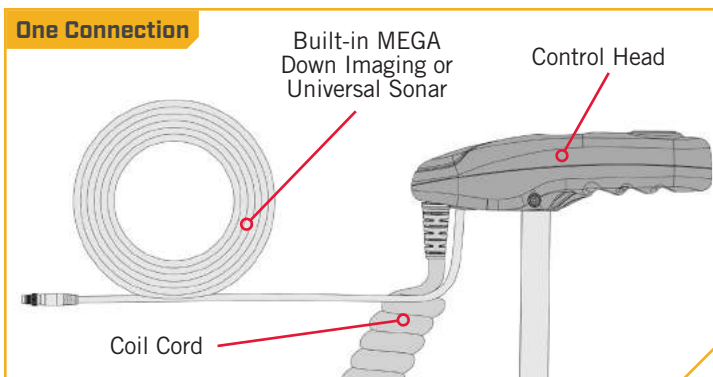

ROUTING CONNECTION CABLES

Please follow these instructions for routing any and all of the cables present for any of the pre-installed features that may come with your trolling motor. This routing should be followed whether there are one or two connection cables present. If you are unsure of the cables present, please review the “Identifying Trolling Motor Features By Their Associated Cables” section of these Installation Instructions.

- 1
 - a. Place the motor in the deployed position.
 - b. Locate the Built-in MEGA Down Imaging, Built-in MEGA Side Imaging, i-Pilot Link and/or Universal Sonar cable(s), at the base of the Control Head.

CAUTION

Not following the recommended wire routing for the Built-in MEGA Down Imaging, Built-in MEGA Side Imaging, i-Pilot Link and/or Universal Sonar cable(s), if equipped, may cause damage to the product and void your product warranty. Route cables away from pinch points or other areas that may cause them to bend in sharp angles. Routing the cables in any way other than directed may cause damage to the cables by being pinched or severed.

NOTICE: Universal Sonar connector shown for illustration purposes.

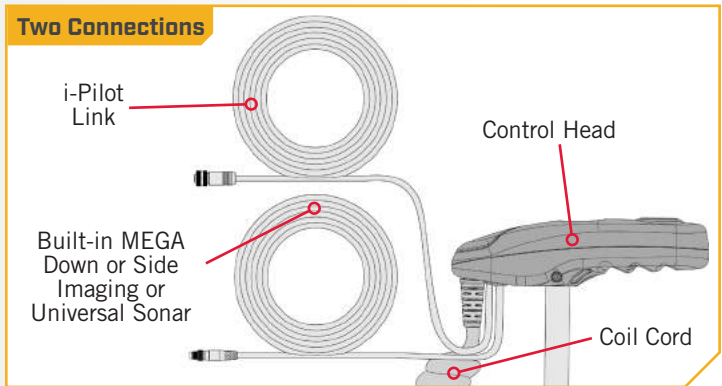
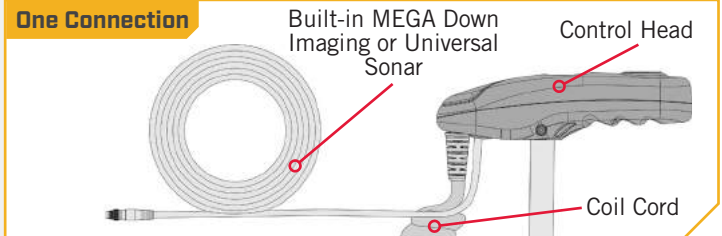

FEATURE OVERVIEW AND CONNECTING THE CABLES

2

- c. The cable(s) should be fed all the way through the Coil Cord. It/they should exit the Coil Cord at the bottom of the Coil Cord, where it connects to the Mount.

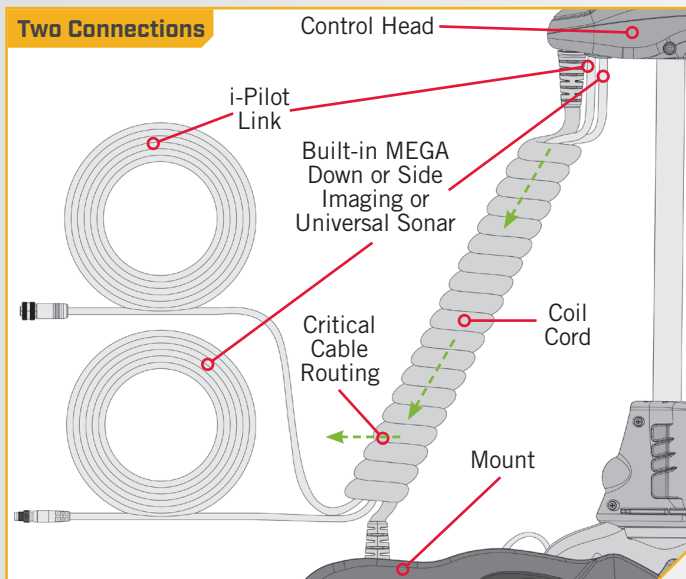

NOTICE: Critical cable routing for 60" and 72" motors with i-Pilot Link and Built-in MEGA Imaging. Accessory Cables must exit the Coil Cord leaving three or more open coils between where the cables exit and the motor base; as assembled by the factory. Routing the cables in any other manner will not allow the motor to stow properly.

One Connection

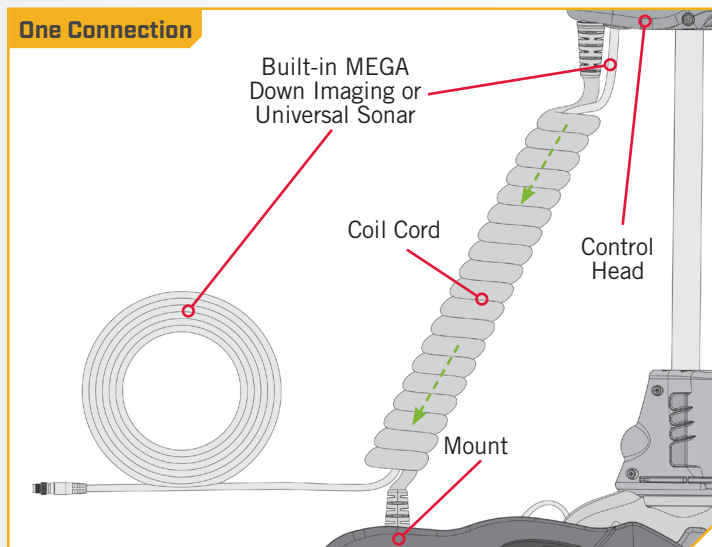

NOTICE: After the cable(s) exit(s) the Coil Cord, it/they should be routed through an established routing system on the boat, in an area with minimal interference. Power cables or other elements that may produce interference for the sonar signals. Inspect the selected route carefully to ensure that there are no sharp edges, obstacles, or obstructions that may damage the cables.

FEATURE OVERVIEW AND CONNECTING THE CABLES

The cables from the Control Head, for each feature installed on the trolling motor, are separately connected to an output device. Once the features that may be installed are identified, follow the instructions below to ensure the cables are connected correctly.

› Built-In MEGA Side Imaging

MEGA Imaging technology took fish finding into the megahertz frequency for the very first time. Now built-In MEGA Side Imaging+ delivers up to 3X the output of standard Side Imaging®. Humminbird improved this technology even further by extending the depth range and expanding the side coverage areas, all while improving the crystal clear imagery. Built-In MEGA Side Imaging+ comes available in the Minn Kota flagship families of trolling motors, including Ultrex and Ultrera, with 200 feet of coverage on either side of your boat. With Humminbird MEGA imaging sonar built right into the trolling motor, you now have a crystal clear view of what's directly to the left and right of your boat, without having to manage all of the cables that come with external transducers. The Built-In MEGA SI transducer is only available on new models equipped from the factory and cannot be added to an existing trolling motor.

The Built-in MEGA SI transducer will provide MEGA Side Imaging to select Humminbird models. All Built-In MEGA SI trolling motors, will come "Solix Ready" out of the box. An adapter cable accessory (MKR-MI-1 1852088) is available for purchase that will allow the connection of any compatible Humminbird Helix fish finder. The MKR-MI-1 is used on Helix 8, 9, 10 and 12 models. See the [Built-In MEGA Side Imaging Compatibility](#) chart online.

FEATURE OVERVIEW AND CONNECTING THE CABLES

NOTICE: You can only view MEGA Side Imaging with a MEGA DI or MEGA SI HELIX G2N or G3N Series model and a required adapter, or with any SOLIX Series model. The built-in transducer cannot supply MEGA Down Imaging to Humminbird models that do not already have the capability. If you have a G2/G2N or a G3/G3N HELIX that is not a MEGA SI or MEGA DI model, you will still get 2D Dual Spectrum CHIRP Sonar from the transducer. SOLIX G1 and HELIX G2 and G2N units need to be running the latest software update to view sonar from motors with Built-In MEGA Imaging. You can get the latest version of software for your fish finder online on humminbird.com. Built-In MEGA SI is not supported by HELIX G1 models or other brands of fish finders.

1

- a. Place the motor in the deployed position.
- b. The Built-In MEGA Side Imaging connector from the Control Head is a 14 pin connector. Built-In MEGA Side Imaging is only installed with motors installed with the i-Pilot Link system. Locate and identify the correct connection for Built-in MEGA Side Imaging cable(s), at the base of the Control Head.

NOTICE: Built-in MEGA Side Imaging is only paired with i-Pilot Link on either an Ultrex or Ultrera motor.

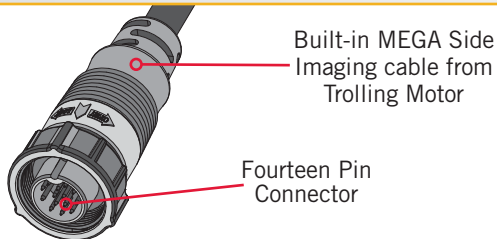

Built-in MEGA Side Imaging

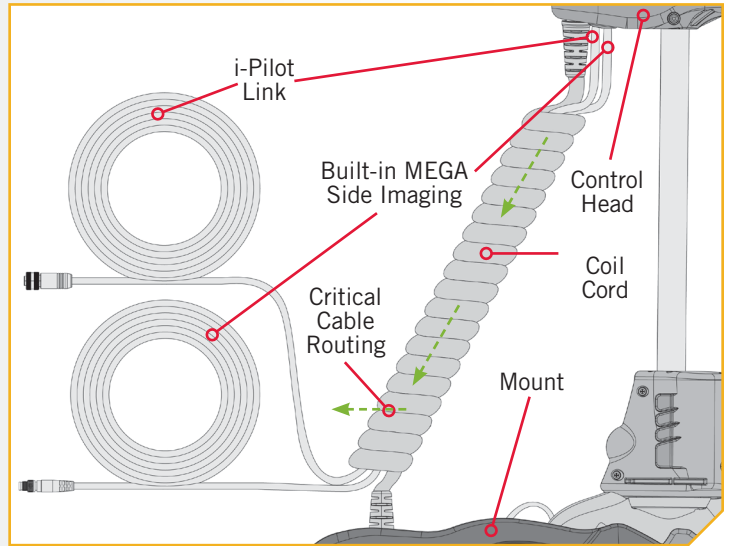
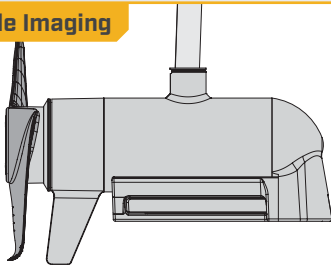

NOTICE: Critical cable routing for 60" and 72" motors with i-Pilot Link and Built-in MEGA Imaging. Accessory Cables must exit the Coil Cord leaving three or more open coils between where the cables exit and the motor base; as assembled by the factory. Routing the cables in any other manner will not allow the motor to stow properly.

FEATURE OVERVIEW AND CONNECTING THE CABLES

2

- c. **When installing with a Solix**, the Built-In MEGA Side Imaging cable can be plugged directly into the Solix fish finder. Plug the Built-in MEGA Side Imaging cable into the corresponding connection on the Solix fish finder.
- d. **When installing with a Helix**, first attach the Adapter Cable and then plug the Adapter Cable into the Helix fish finder. The Adapter Cable will only have one connection that is keyed on the back of the Helix fish finder. Plug the Adapter Cable into the only matching keyed connection on the Helix fish finder.

NOTICE: Check for compatibility or any required adapter cables online at minnkotamotors.com. The cable from the trolling motor can be extended with a 10' Extension Cable #720081-1 found at humminbird.com.

NOTICE: If any cables need to be routed, please follow the guidelines in the Routing Connection Cables section of these installation instructions.

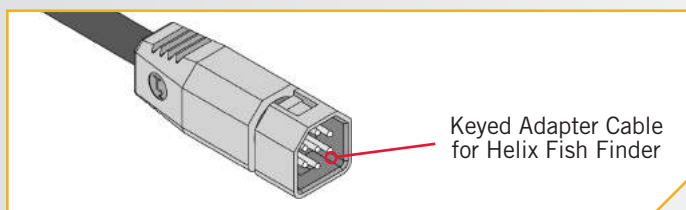

NOTICE: The connectors are keyed to prevent reversed installation.

Humminbird Solix Fish Finder

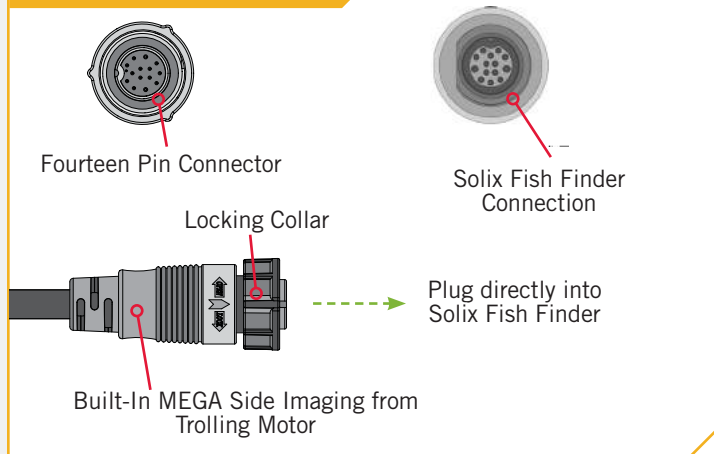

Humminbird Helix Fish Finder

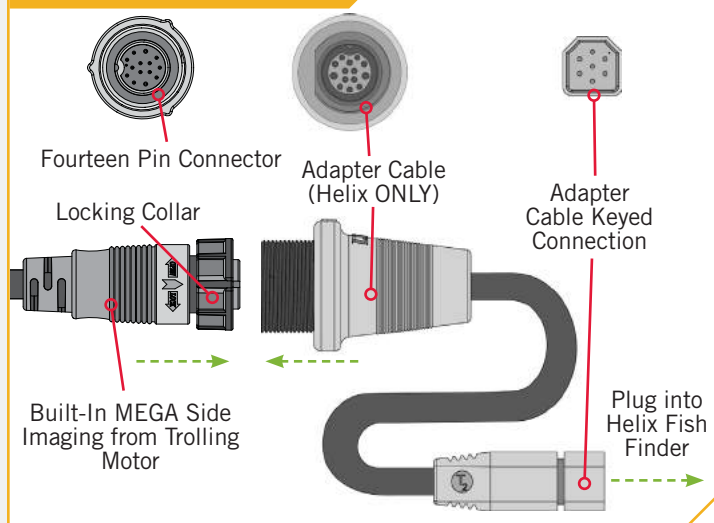

NOTICE: The MKR-MI-1 (1852088) is used on Helix 8, 9, 10 and 12 models.

› Built-In MEGA Down Imaging

Built-In MEGA Down Imaging delivers nearly 3X the output of standard Side Imaging®, and takes fishfinding into the megahertz frequency for the very first time. The Minn Kota flagship families of trolling motors, including Ultrex, Ulterra, Terrova, and Fortrex, now include Built-In MEGA Down Imaging sonar, the clearest imaging available only from Humminbird. With Humminbird MEGA imaging sonar built right into the trolling motor, you now have a crystal clear view of what's directly beneath the boat, without having to manage all of the cables that come with external transducers. The Built-In MEGA DI transducer is only available on new models equipped from the factory and cannot be added to an existing trolling motor.

FEATURE OVERVIEW AND CONNECTING THE CABLES

The Built-in MEGA DI transducer will provide both MEGA Down Imaging and 2D CHIRP Digital Sonar to select Humminbird models. All Built-In MEGA DI trolling motors, will come “Solix Ready” out of the box. An adapter cable accessory (MKR-MI-1 1852088 or MKR-MDI-2 1852086) is available for purchase that will allow the connection of any compatible Humminbird Helix fish finder. The MKR-MI-1 is used on Helix 8, 9, 10 and 12 models. The MKR-MDI-2 is used for Humminbird Helix 7 models only. See the [Built-In MEGA Down Imaging Compatibility](#) chart online.

NOTICE: You can only view MEGA Down Imaging with a MEGA DI or MEGA SI HELIX G2N or G3N Series model and a required adapter, or with any SOLIX Series model. The built-in transducer cannot supply MEGA Down Imaging to Humminbird models that do not already have the capability. If you have a G2/G2N or a G3/G3N HELIX that is not a MEGA SI or MEGA DI model, you will still get 2D CHIRP Digital Sonar from the transducer. SOLIX G1 and HELIX G2 and G2N units need to be running the latest software update to view sonar from motors with Built-In MEGA Imaging. You can get the latest version of software for your fish finder online on humminbird.com. Built-In MEGA DI is not supported by HELIX G1 models or other brands of fish finders.

1

- a. Place the motor in the deployed position.
- b. The Built-In MEGA Down Imaging connector from the Control Head is a 14 pin connector. Built-In MEGA Down Imaging may be installed on its own, or in conjunction with an i-Pilot or i-Pilot Link system. It will never be installed with Universal Sonar. Locate and identify the correct connection for Built-in MEGA Down Imaging cable(s), at the base of the Control Head.

NOTICE: Built-in MEGA Down Imaging is always paired with either i-Pilot or i-Pilot Link on Terrova, Ultra and Ultrex motors.

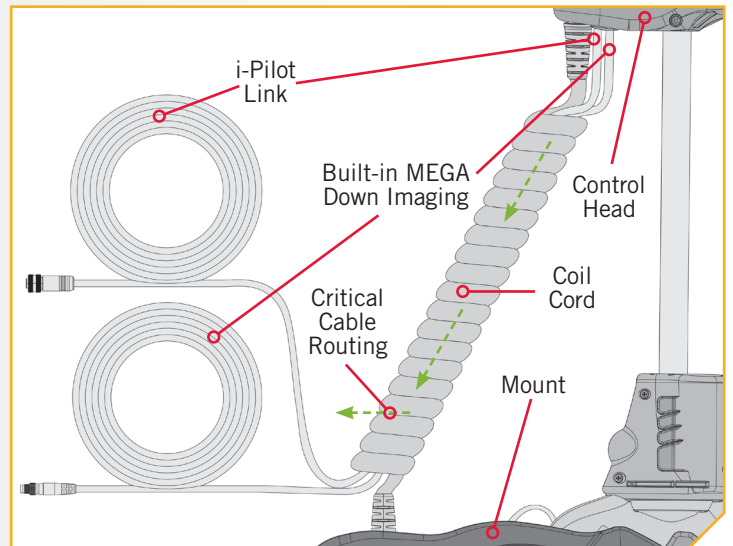

Fourteen Pin Connector
Built-in MEGA Down Imaging cable from Trolling Motor

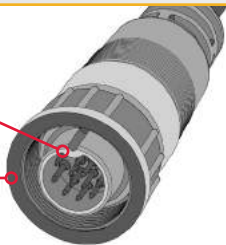

NOTICE: Critical cable routing for 60" and 72" motors with i-Pilot Link and Built-in MEGA Imaging. Accessory Cables must exit the Coil Cord leaving three or more open coils between where the cables exit and the motor base; as assembled by the factory. Routing the cables in any other manner will not allow the motor to stow properly.

Built-in MEGA Down Imaging

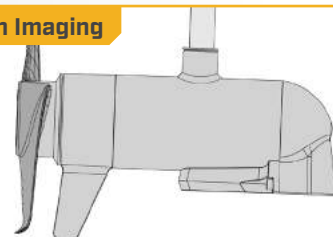

FEATURE OVERVIEW AND CONNECTING THE CABLES

2

- c. **When installing with a Solix**, the Built-In MEGA Down Imaging cable can be plugged directly into the Solix fish finder. Plug the Built-in MEGA Down Imaging cable into the corresponding connection on the Solix fish finder.
- d. **When installing with a Helix**, first attach the Adapter Cable and then plug the Adapter Cable into the Helix fish finder. The Adapter Cable will only have one connection that is keyed on the back of the Helix fish finder. Plug the Adapter Cable into the only matching keyed connection on the Helix fish finder.

NOTICE: Check for compatibility or any required adapter cables online at minnkotamotors.com. The cable from the trolling motor can be extended with a 10' Extension Cable #720081-1 found at humminbird.com.

NOTICE: If any cables need to be routed, please follow the guidelines in the Routing Connection Cables section of these installation instructions.

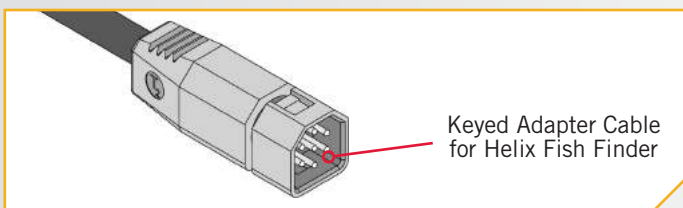

NOTICE: The connectors are keyed to prevent reversed installation.

Humminbird Solix Fish Finder

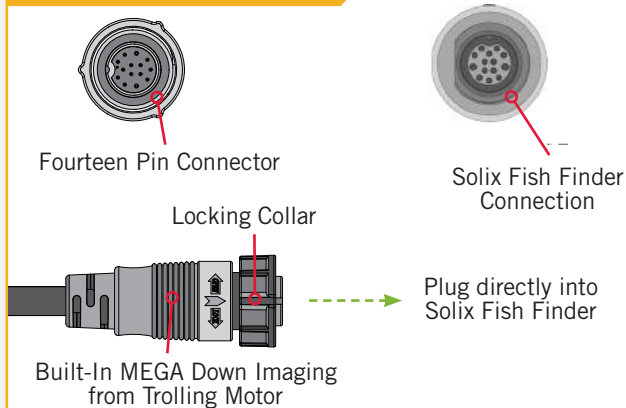

Humminbird Helix Fish Finder

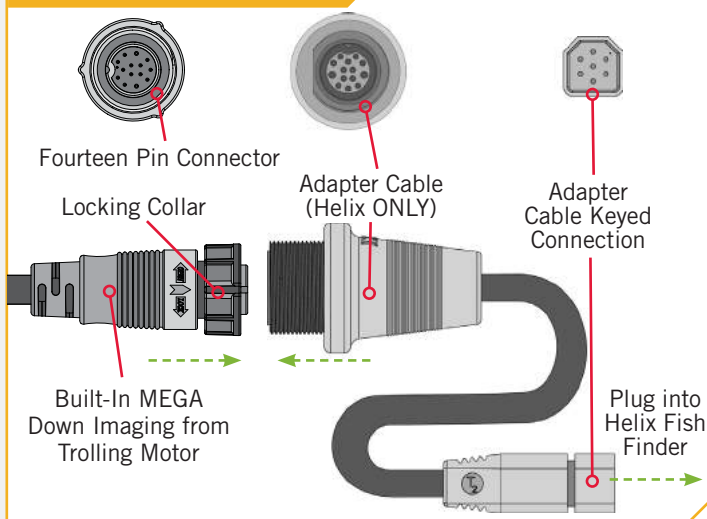

NOTICE: The MKR-MI-1 is used on Helix 8, 9, 10 and 12 models. The MKR-MDI-2 is used for Humminbird Helix 7 models only.

› Universal Sonar

Your trolling motor may be pre-installed with a Universal Sonar transducer system. Universal Sonar is a 2D sonar transducer with a temperature sensor that is integrated into the lower unit of the trolling motor. It has an operating frequency of 83/200 kHz. Connecting this transducer to a compatible fish finder gives you a 2D sonar view of what is happening directly below your trolling motor. The integrated design protects the transducer from underwater hazards, and prevents tangles and damage to the transducer cables.

All Universal Sonar motors are equipped with an internal bonding wire, incorrect rigging will cause sonar interference and can damage your trolling motor, electronics and other boat accessories. To minimize trolling motor interference, ensure that the fish finder and trolling motor are powered by separate batteries. Please refer to the Battery & Wiring Installation and Motor Wiring Diagram sections of this manual for correct rigging instructions.

FEATURE OVERVIEW AND CONNECTING THE CABLES

The Universal Sonar Cables are shielded to minimize interference. To protect this shielding the cables should not be pulled tight against sharp angles or hard objects. If using cable ties, do not over-tighten. Any excess cable should be bundled in a loose loop of no less than 4" in diameter. In certain situations, air bubbles may adhere to the surface of the Universal Sonar transducer, and affect the performance. If this happens simply wipe the surface of the transducer with your finger.

NOTICE: Universal Sonar does not support imaging screens that require higher frequencies such as 455 kHz, 800 kHz or 1.2mHz (Down Imaging, Side Imaging, etc.). Down Imaging (DI) specific units are not compatible with Universal Sonar. See compatibility chart for a list of compatible fish finders at minnkotamotors.com.

The connector for Universal Sonar exits the trolling motor below the Control Head and consists of a 4-pin plug. An adapter cable (sold separately) will convert the 4-pin plug to the correct transducer connector for your fish finder, and is required for all installations. For a current list of compatible fish finders and the correct adapter cable, or more information on Universal Sonar, please visit minnkotamotors.com.

- 1
 - a. Place the motor in the deployed position.
 - b. Locate the Universal Sonar, if equipped, at the base of the Mount.
 - c. Locate the Universal Sonar four pin connector at the end of Universal Sonar Extension Cable. The connector is black with a stainless steel threaded locking collar.

NOTICE: Your fish finder should be turned off until this procedure is complete.

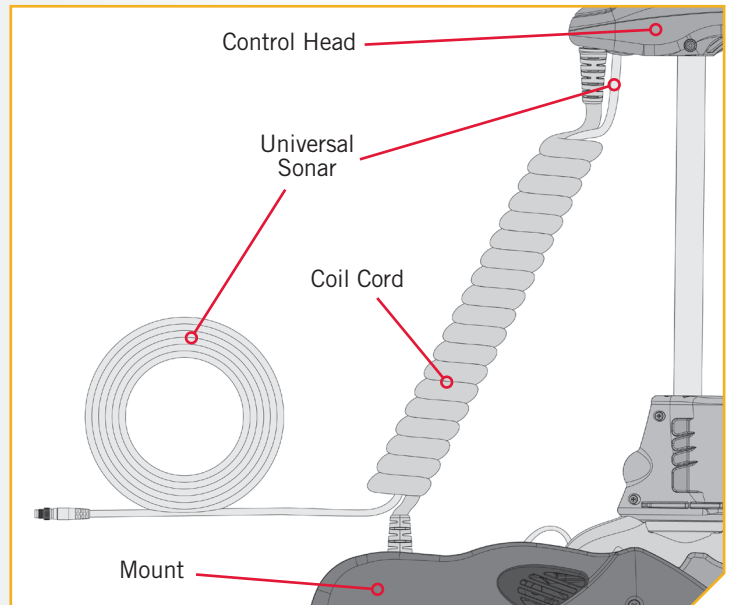
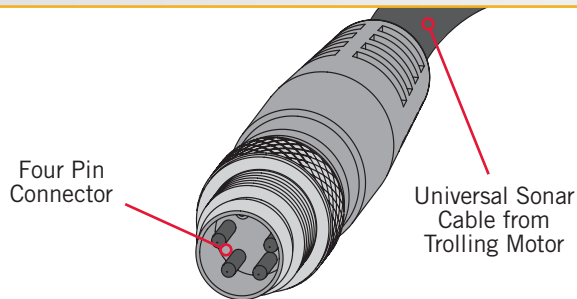

NOTICE: If the cable length does not reach the desired fish finder installation location, a 14.5' extension cable is available (MKR-US2-11) (sold separately).

FEATURE OVERVIEW AND CONNECTING THE CABLES

2

NOTICE: The Universal Sonar Cable may not be long enough to reach the fish finder. If the cable length does not reach the desired fish finder installation location, a 14.5' extension cable is available to purchase. Minn Kota recommends using the MKR-US2-11.

- d. Take the Universal Sonar Extension Cable, if needed, and attach it to the Universal Sonar Cable exiting the Control Head. Firmly push the plug together and twist the locking collar until it is snug.
- e. Install the Universal Sonar Cable that exists the Control Head or the Universal Sonar Extension Cable (if used) to the appropriate Universal Sonar Adapter Cable. Install the Adapter Cable to your fish finder. Refer to your fish finder manual for complete installation instructions.

NOTICE: If any cables need to be routed, please follow the guidelines in the Routing Connection Cables section of these installation instructions.

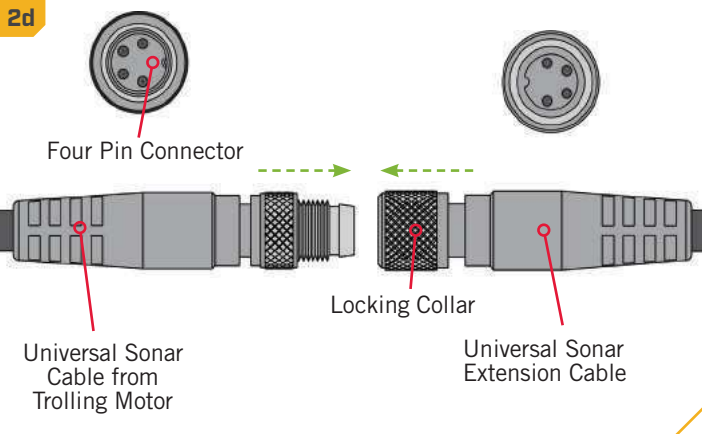

NOTICE: The connectors are keyed to prevent reversed installation.

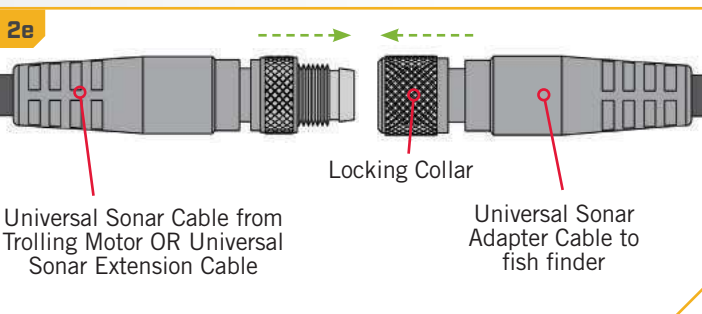

› i-Pilot Link

i-Pilot Link allows your Minn Kota trolling motor and Humminbird to communicate with each other to change the way you fish. i-Pilot Link delivers a large array of GPS capabilities including controlling speed, steering, Spot-Lock, and the ability to record and retrace paths on the water, all at your fingertips. To learn more about the GPS capabilities available with your i-Pilot Link navigation system, please refer to the Owner's Manual by visiting minnkotamotors.com.

The i-Pilot Link remote and controller make up the i-Pilot Link navigation system. The i-Pilot Link remote comes paired to the controller from the factory. The i-Pilot Link controller contains a very sensitive compass and is where all GPS satellite and i-Pilot Link remote signals are received. The i-Pilot Link controller is contained in the trolling motor Control Head and is connected to a fish finder from a connection cable that exits the Control Head.

The Ethernet cable for the i-Pilot Link system has an 8 pin connector. The i-Pilot Link system can be connected directly to the Humminbird or to the Humminbird Ethernet Switch (optional). If you purchase an Ethernet Switch, install it using the instructions included in the Ethernet Installation Guide. A 30' Ethernet Extension Cable has been included with every motor equipped with i-Pilot Link. It may or may not be needed for every installation. To purchase Ethernet switches, Ethernet cables, and extension cables, visit the web site humminbird.com or call Humminbird Customer Service at 1-800-633-1468. Depending on the shape of the Ethernet port on your Humminbird fish finder, an additional ethernet adapter cable (**Ethernet Adaptor Cable AS EC QDE #720074-1 for Helix fish finders**) may be

NOTICE: The i-Pilot Link system needs an external wired connection. The i-Pilot system does not need an external wired connection.

FEATURE OVERVIEW AND CONNECTING THE CABLES

required for the installation. Refer to your fish finder operations manual or see the [i-Pilot Link Compatibility Chart](#) on our web site with a list of all compatible Humminbird Units and SD Cards.

1

- a. Place the motor in the deployed position.
- b. The i-Pilot Link connector from the Control Head is an 8 pin connector. Locate and identify the correct connection for i-Pilot Link, at the base of the Control Head.

NOTICE: i-Pilot Link will be paired with either Built-in MEGA Down Imaging, Side Imaging or Universal Sonar on Ultrex, Ultra or Terra.

NOTICE: Paired with a Universal Sonar connector for illustration purposes. A Built-in MEGA Down Imaging connector may be present instead.

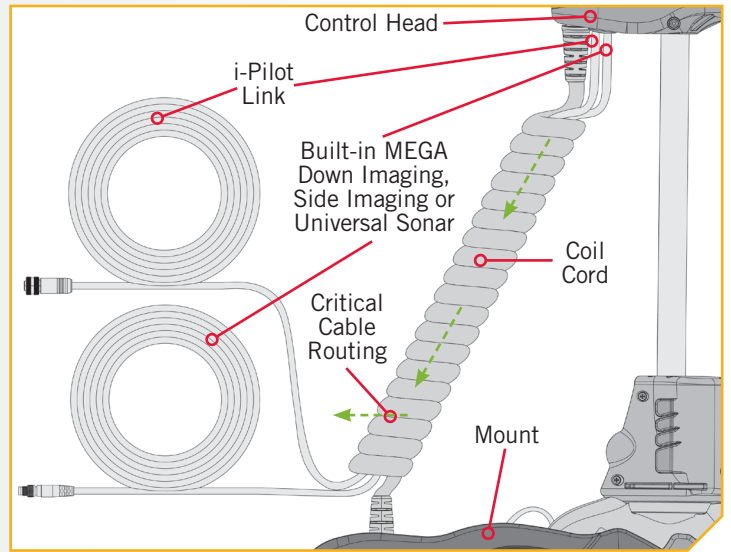

NOTICE: Critical cable routing for 60" and 72" motors with i-Pilot Link and Built-in MEGA Imaging. Accessory Cables must exit the Coil Cord leaving three or more open coils between where the cables exit and the motor base; as assembled by the factory. Routing the cables in any other manner will not allow the motor to stow properly.

2

ITEM(S) NEEDED



- c. If necessary, to reach the installed fish finder, take the i-Pilot Link Ethernet Cable (Item #16) and attach it to the i-Pilot Link cable exiting the Control Head.

NOTICE: If any cables need to be routed, please follow the guidelines in the Routing Connection Cables section of these installation instructions.

- d. Install the i-Pilot Link Ethernet Cable directly into the Humminbird fish finder, or refer to your fish finder installation manual for complete installation instructions. If an Adapter Cable is needed (Ethernet Adaptor Cable AS EC QDE for Helix fish finders), install it on the end of the i-Pilot Link Ethernet Cable and refer to your fish finder installation manual for complete installation instructions.

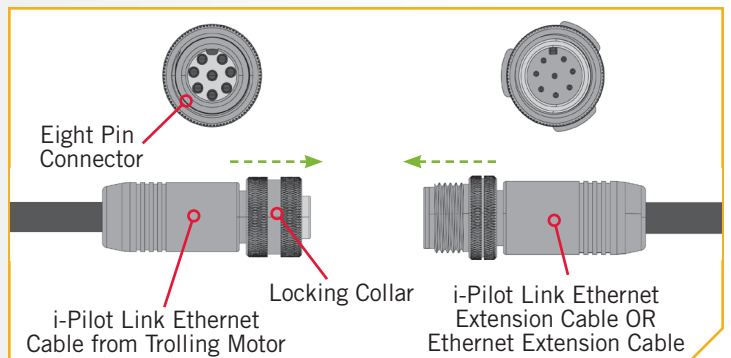

NOTICE: The connectors are keyed to prevent reversed installation.

BATTERY & WIRING INSTALLATION

BOAT RIGGING & PRODUCT INSTALLATION

For safety and compliance reasons, we recommend that you follow American Boat and Yacht Council (ABYC) standards when rigging your boat. Altering boat wiring should be completed by a qualified marine technician. The following specifications are for general guidelines only:

CAUTION

These guidelines apply to general rigging to support your Minn Kota motor. Powering multiple motors or additional electrical devices from the same power circuit may impact the recommended conductor gauge and circuit breaker size. If you are using wire longer than that provided with your unit, follow the conductor gauge and circuit breaker sizing table below. If your wire extension length is more than 25 feet, we recommend that you contact a qualified marine technician.

CAUTION

An over-current protection device (circuit breaker or fuse) must be used. Coast Guard requirements dictate that each ungrounded current-carrying conductor must be protected by a manually reset, trip-free circuit breaker or fuse. The type (voltage and current rating) of the fuse or circuit breaker must be sized accordingly to the trolling motor used. The table below gives recommended guidelines for circuit breaker sizing.

CONDUCTOR GAUGE AND CIRCUIT BREAKER SIZING TABLE

This conductor and circuit breaker sizing table is only valid for the following assumptions:

1. No more than 2 conductors are bundled together inside of a sheath or conduit outside of engine spaces.
2. Each conductor has 105° C temp rated insulation.
3. No more than 5% voltage drop allowed at full motor power based on published product power requirements.

Motor Thrust / Model	Max Amp Draw	Circuit Breaker	Wire Extension Length				
			5 feet	10 feet	15 feet	20 feet	25 feet
30 lb.	30	50 Amp @ 12 VDC	10 AWG	10 AWG	8 AWG	6 AWG	4 AWG
40 lb., 45 lb.	42		10 AWG	8 AWG	6 AWG	4 AWG	4 AWG
50 lb., 55 lb.	50	60 Amp @ 12 VDC	8 AWG	6 AWG	4 AWG	4 AWG	2 AWG
70 lb.	42	50 Amp @ 24 VDC	10 AWG	10 AWG	8 AWG	8 AWG	6 AWG
80 lb.	56	60 Amp @ 24 VDC	8 AWG	8 AWG	8 AWG	6 AWG	6 AWG
101 lb.	46	50 Amp @ 36 VDC	8 AWG	8 AWG	8 AWG	8 AWG	8 AWG
Engine Mount 101	50	60 Amp @ 36 VDC	8 AWG	8 AWG	8 AWG	8 AWG	8 AWG
112 lb.	52	60 Amp @ 36 VDC	8 AWG	8 AWG	8 AWG	8 AWG	8 AWG
Engine Mount 160	116	(2) x 60 Amp @ 24 VDC	6 AWG	6 AWG	4 AWG	2 AWG	2 AWG
E-Drive	40	50 Amp @ 48 VDC	10 AWG	10 AWG	10 AWG	10 AWG	10 AWG

NOTICE: Wire Extension Length refers to the distance from the batteries to the trolling motor leads. Consult website for available thrust options. Maximum Amp Draw values only occur intermittently during select conditions and should not be used as continuous amp load ratings.

Reference

United States Code of Federal Regulations: 33 CFR 183 – Boats and Associated Equipment ABYC E-11: AC and DC Electrical Systems on Boats

SELECTING THE CORRECT BATTERIES

The motor will operate with any lead acid, deep cycle marine 12 volt battery/batteries. For best results, use a deep cycle, marine battery with at least a 105 amp-hour rating. Maintain battery at full charge. Proper care will ensure having battery power when you need it, and will significantly improve the battery life. Failure to recharge lead-acid batteries (within 12-24 hours) is the leading cause of premature battery failure. Use a multi-stage charger to avoid overcharging. We offer a wide selection of chargers to fit your charging needs. If you are using a crank battery to start a gasoline outboard, we recommend that you use a separate deep cycle marine battery/batteries for your Minn Kota trolling motor. For more information on battery selection and rigging, please visit minnkotamotors.com. Minn Kota trolling motors can run on Lithium Ion batteries. However, they are specifically designed to run on traditional lead acid batteries (flooded, AMG or GEL). Lithium Ion batteries maintain higher voltages for longer periods of time than lead acid. Therefore, running a Minn Kota trolling motor at speeds higher than 85% for a prolonged period could cause permanent damage to the motor.

WARNING

Never connect the (+) and the (-) terminals of the same battery together. Take care that no metal object can fall onto the battery and short the terminals. This would immediately lead to a short and extreme fire danger.

CAUTION

Refer to “Conductor Gauge and Circuit Breaker Sizing Table” in the previous section to find the appropriate circuit breaker or fuse for your motor. For motors requiring a 60-amp breaker, the Minn Kota MKR-19 60-amp circuit breaker is recommended.

CAUTION

Please read the following information before connecting your motor to your batteries in order to avoid damaging your motor and/or voiding your warranty.

ADDITIONAL CONSIDERATIONS

› Using Alternator Chargers

Your Minn Kota trolling motor may be designed with an internal bonding wire to reduce sonar interference. Most alternator charging systems do not account for this bonding wire, and connect the negative posts of the trolling motor batteries to the negative posts of the crank/starting battery. These external connections can damage connected electronics and the electrical system of your trolling motor, voiding your warranty. Review your charger’s manual carefully or consult the manufacturer prior to use to ensure your charger is compatible.

Minn Kota recommends using Minn Kota brand chargers to recharge the batteries connected to your Minn Kota trolling motor, as they have been engineered to work with motors that include a bonding wire.

› Additional Accessories Connected to Trolling Motor Batteries

Significant damage to your Minn Kota motor, your boat electronics, and your boat can occur if incorrect connections are made between your trolling motor batteries and other battery systems. Minn Kota recommends using an exclusive battery system for your trolling motor. Where possible, accessories should be connected to a separate battery system. Radios and sonar units should not be connected to any trolling motor battery systems as interference from the trolling motor is unavoidable. If connecting any additional accessories to any trolling motor battery system, or making connections between the trolling motor batteries and other battery systems on the boat, be sure to carefully observe the information below.

CONNECTING THE BATTERIES IN SERIES

The negative (-) connection must be connected to the negative terminal of the same battery that the trolling motor negative lead connects to. In the diagrams below this battery is labeled “Low Side” Battery. Connecting to any other trolling motor battery will input positive voltage into the “ground” of that accessory, which can cause excess corrosion. Any damage caused by incorrect connections between battery systems will not be covered under warranty.

Automatic Jump Start Systems and Selector Switches

Automatic jump start systems and selector switches tie the negatives of the connected batteries together. Connecting these systems to the “High Side” Battery or “Middle” Battery in the diagrams below and will cause significant damage to your trolling motor and electronics. The only trolling motor battery that is safe to connect to one of these systems is the “Low Side” Battery.

NOTICE: The internal bonding wire is equipped with a 3 amp fuse. Improper connections described above carrying in excess of 3 amps will blow this fuse and no further damage will be exhibited. If this occurs, RF interference from the trolling motor affecting sonar units and other electronics will be more significant. If the fuse is blown the wiring error should be found and addressed prior to replacing the fuse. The replacement fuse should be 3 amps or less. An intact fuse does not imply correct rigging; significant damage can be done by incorrect wiring without approaching 3 amps of current.

CONNECTING THE BATTERIES IN SERIES (IF REQUIRED FOR YOUR MOTOR)

24 Volt Systems

Two 12 volt batteries are required. The batteries must be wired in series, only as directed in wiring diagram, to provide 24 volts.

1. Make sure that the motor is switched off (speed selector on “0”).
2. Connect a connector cable to the positive (+) terminal of battery 1 and to the negative (-) terminal of battery 2.
3. Connect positive (+) red motor lead to positive (+) terminal on battery 2.
4. Connect negative (-) black motor lead to negative (-) terminal of battery 1.

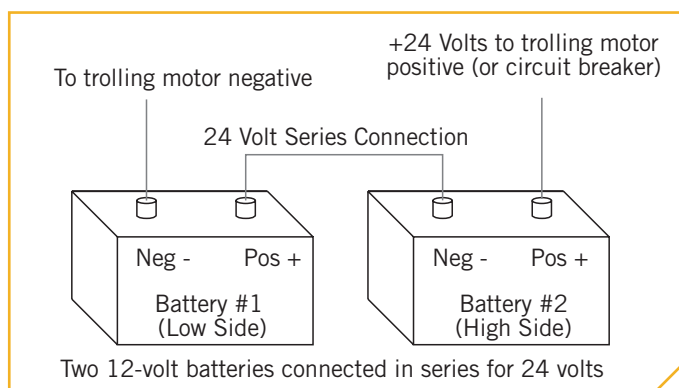

WARNING

For safety reasons do not switch the motor on until the propeller is in the water. If installing a leadwire plug, observe proper polarity and follow instructions in your boat owner’s manual.

WARNING

- For safety reasons, disconnect the motor from the battery or batteries when the motor is not in use or while the battery/batteries are being charged.
- Improper wiring of 24/36 volt systems could cause battery explosion.
- Keep leadwire wing nut connections tight and solid to battery terminals.
- Locate battery in a ventilated compartment.

CONNECTING THE BATTERIES IN SERIES

36 Volt Systems

Three 12 volt batteries are required. The batteries must be wired in series, only as directed in wiring diagram, to provide 36 volts.

1. Make sure that the motor is switched off (speed selector on "0").
2. Connect a connector cable to the positive (+) terminal of battery 1 and to the negative (-) terminal of battery 2 and another connector cable from the positive (+) terminal of battery 2 to the negative (-) terminal of battery 3.
3. Connect positive (+) red motor lead to positive (+) terminal on battery 3.
4. Connect negative (-) black motor lead to negative (-) terminal of battery 1.

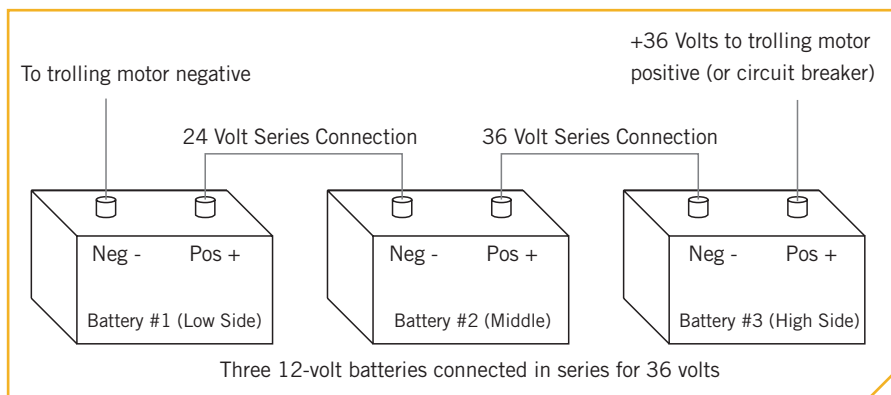

WARNING

For safety reasons do not switch the motor on until the propeller is in the water. If installing a leadwire plug, observe proper polarity and follow instructions in your boat owner's manual.

WARNING

- For safety reasons, disconnect the motor from the battery or batteries when the motor is not in use or while the battery/batteries are being charged.
- Improper wiring of 24/36 volt systems could cause battery explosion.
- Keep leadwire wing nut connections tight and solid to battery terminals.
- Locate battery in a ventilated compartment.

MOTOR WIRING DIAGRAM

ULTERRA WITH i-PILOT OR i-PILOT LINK

The following Motor Wiring Diagram applies to all Ulterra models that come factory installed with either i-Pilot or i-Pilot Link. Universal Sonar or Built-in MEGA Down Imaging are optional features that may come factory installed.

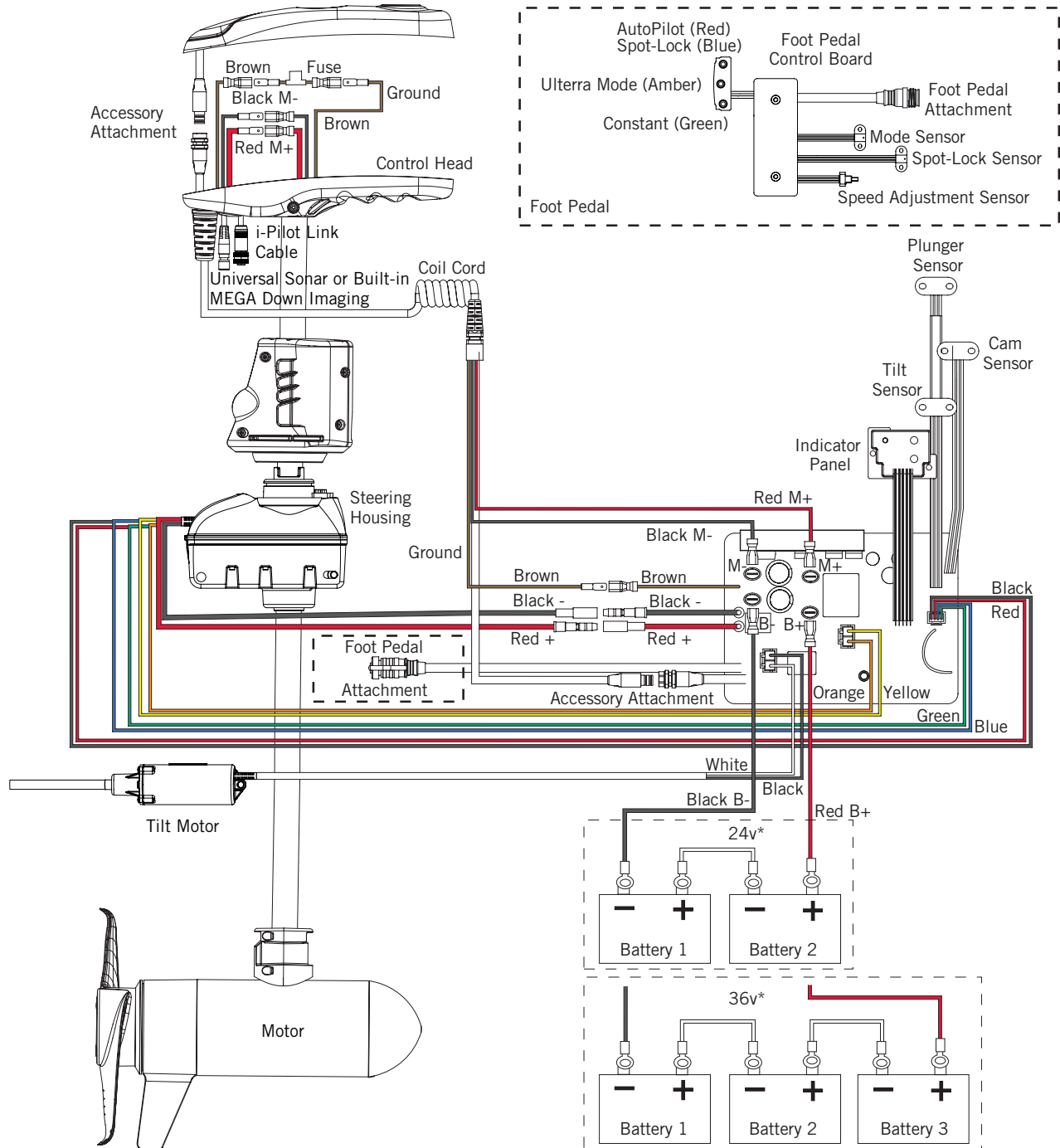

NOTICE: This is a multi-voltage diagram. Double-check your motor's voltage for proper connections. Over-Current Protection Devices are not shown in this illustration. i-Pilot Link Cable attachment for i-Pilot Link only models only. If equipped with Universal Sonar or Built-in MEGA Down or Side Imaging, please visit minnkotamotors.com to learn more.



USING & ADJUSTING THE MOTOR

MOUNT FEATURES

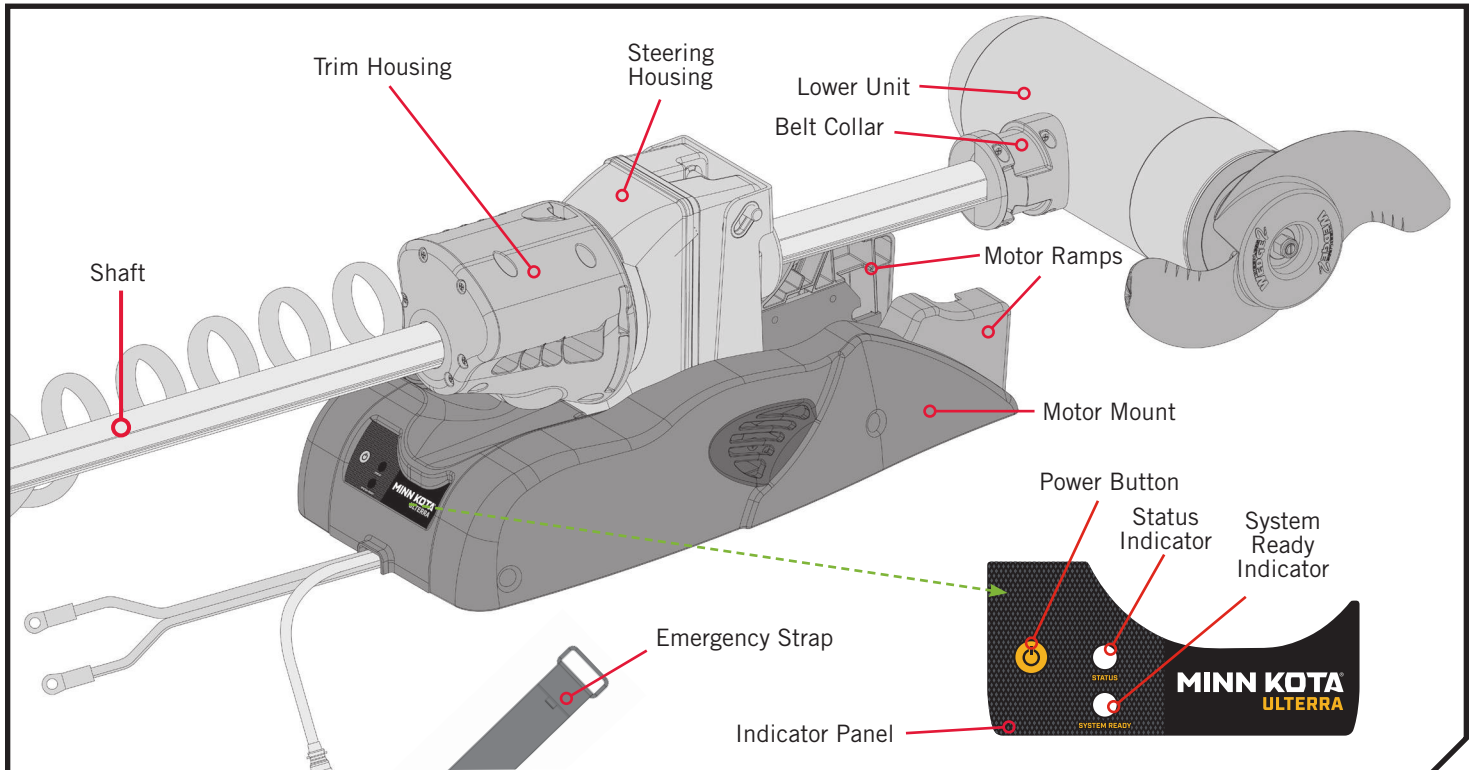
Become familiar with the features of the motor to maximize the capabilities this product offers.



Power Button

The Ultra must be powered “on” and “off” manually. The remote will not turn the motor “on” or “off”. The Power button  is located on the base of the motor on the Indicator Panel. Press the Power button to turn the motor “on”. When the motor is in the stowed position, the Status Indicator  will be illuminated red and the System Ready Indicator  will be illuminated green when powered “on”. To power the motor “off”, press and hold the Power button approximately three seconds, until the green light turns off. Ultra has an auto-shut off as well. It will automatically power off after 1.5 hours of inactivity in the stowed position.



NOTICE: Remember to turn the power off when the motor is not in use to prevent the motor from draining the battery.

CAUTION

Make sure that the Power switch is turned off when the motor is not in use. If the motor control is left on and the propeller rotation is blocked, severe motor damage can result.

For safety reasons, disconnect the motor from the battery/batteries when the motor is not in use or while the battery/batteries are being charged.



Status Indicator

The Status Indicator is located on the Indicator Panel on the base of the motor and works while the motor is powered “on”. The LED associated with the Status Indicator will be illuminated  red when the motor is stowed and will not be illuminated  when the motor is deployed. When the motor is being either stowed or deployed, the red LED will be flashing.

MOUNT FEATURES



› System Ready Indicator

The System Ready Indicator is located on the Indicator Panel on the base of the motor and works while the motor is powered “on”. The LED associated with the System Ready Indicator will be illuminated  green when the motor is operating. If the green light does not remain illuminated  after power up, this is an indicator of insufficient voltage/power.

 WARNING
When stowing or deploying the motor, keep fingers clear of all hinges, pivot points, pinch points and all moving parts.

› Motor Mount

The Motor Mount is designed to securely hold the motor in place on the deck of the boat. It functions to stow and lock the motor flat on the deck when not in use by providing secure stowage for transport. The motor mount also positions the motor when it is in the deployed position.

› Mount Ramps

The Mount Ramps functions to hold the Lower Unit in place when the motor is stowed. The Lower Unit will rest on the Mount Ramps when stowed, helping to secure it in place.

› Emergency Strap

The Emergency Strap must be used to place pressure on the motor shaft to hold the lower unit tightly against the Motor Ramps when the motor is manually stowed. The Emergency Strap should be secured every time the motor is manually stowed to prevent damage from high wind, rough water or vibrations, including while the boat is trailered. See the “Manually Stowing the Ulterra” section of the manual for more information on when the Emergency Strap is needed.

› Belt Collar



The Belt Collar holds the lower portion of the Lift Belt in place. The Lift Belt is runs along the motor Shaft and is used to stow and deploy the motor. See the “Adjusting the Left Belt” section of this manual if the Lift Belt becomes loose anywhere along the Shaft above the Belt Collar.

 WARNING
When the motor is being transported, it is important to always stow the Motor and make sure it is locked in place. A secure stow holds the motor in place during transportation when it is subject to high levels of shock and vibration. Failure to stow the motor may result in injury or damage to the unit.





QUICK STOW & DEPLOY

› Deploying the Motor with i-Pilot

- 1
 - a. Press the Home  button.
 - b. Use the Menu Up  and Menu Down  buttons to find the Deploy menu at the bottom of the display screen.

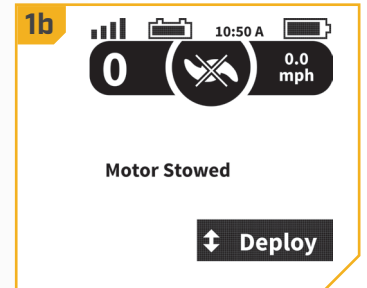
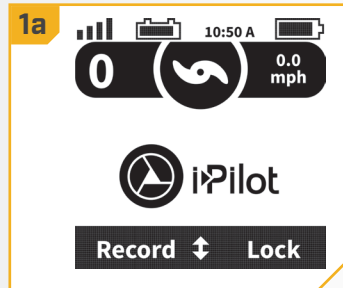

NOTICE: The Deploy menu at the bottom of the display screen can only be found when the motor is stowed.



- 2
 - c. Use the Right Softkey  to select the Deploy menu by double pressing it. Once selected the motor will automatically deploy.



WARNING

As soon as the Deploy menu is selected, the motor will automatically deploy. Be sure the motor is clear from obstructions and has a clear path of travel. The Prop is disabled while the motor is stowed and being deployed to prevent accidental contact with the rotating propeller.

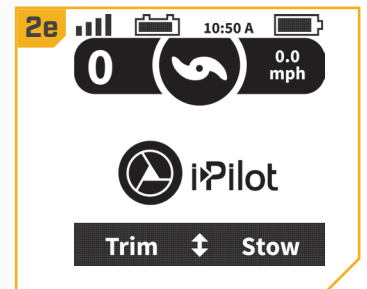
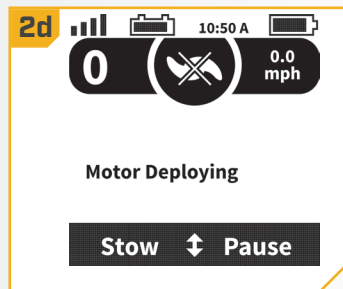
- d. While the Motor is deploying, it is possible to stop the action. Use either the Left Softkey  to select the Stow menu or the Right Softkey  to select the Pause menu.
- e. If the Motor continues, it will complete the deploy process, normal motor operation will follow.



› Stowing the Motor with i-Pilot

- 1
 - a. Press the Home  button.
 - b. Use the Menu Up  and Menu Down  buttons to find the Stow menu at the bottom of the display screen.

NOTICE: The Stow menu at the bottom of the display screen can only be found when the motor is deployed.

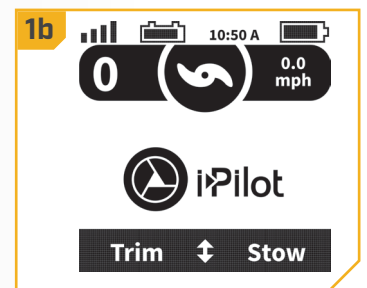
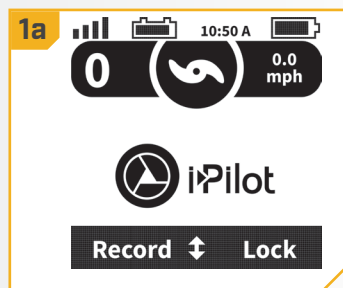



QUICK STOW & DEPLOY

2

- c. Use the Right Softkey  to select the Stow menu. Once selected the motor will automatically stow.

 **WARNING**



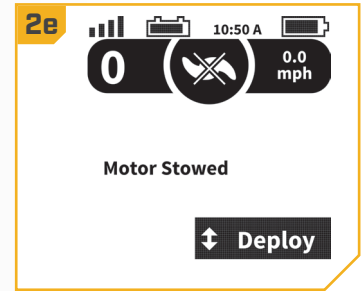
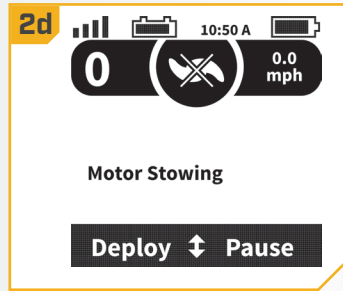

As soon as the Stow menu is selected, the motor will automatically stow. Be sure the motor is clear from obstructions and has a clear path of travel. The Prop is disabled while the motor is being stowed to prevent accidental contact with the rotating propeller.

- d. While the Motor is stowing, it is possible to stop the action. Use either the Left Softkey  to select the Deploy menu or the Right Softkey  to select the Pause menu.
- e. If the Motor continues, it will complete the Stow process and the Prop will be disabled.



Deploying the Motor with i-Pilot Link



1

- a. Press the Home  button.
- b. Scroll through the Content Area using either your finger or the Screen Navigation  button to find the Ulterra  button.
- c. Select the Ulterra  button using either your finger or by pressing the Ok  button to open the Ulterra Menu.

NOTICE: The Ulterra button can only be found in the Content Area with the Home Control Buttons on i-Pilot Link systems on an Ulterra motor. Certain Home Screen Buttons may be locked out while the motor is stowed because those functions require the motor to be deployed to operate.





2

- d. Once in the Ulterra Menu, find the Deploy  button and select it. The Deploy  button requires a double press to engage.

WARNING

As soon as the Deploy button is selected, the motor will automatically deploy. Be sure the motor is clear from obstructions and has a clear path of travel. The Prop is disabled while the motor is stowed and being deployed to prevent accidental contact with the rotating propeller.



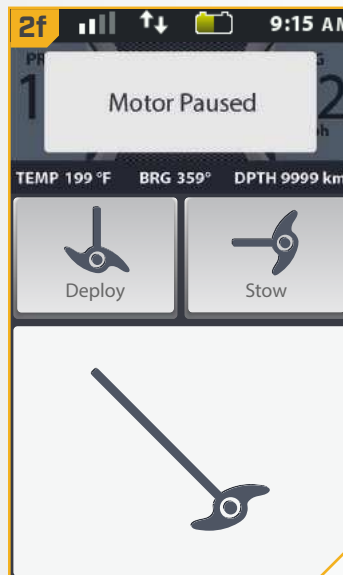
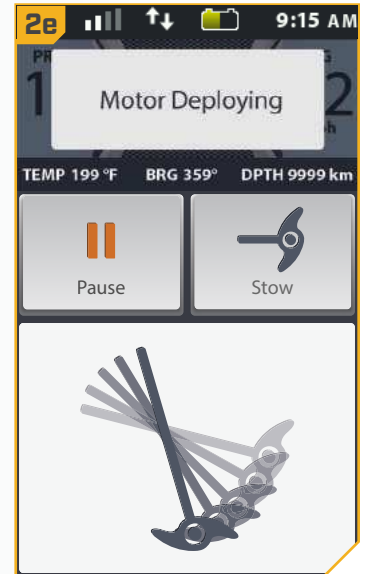
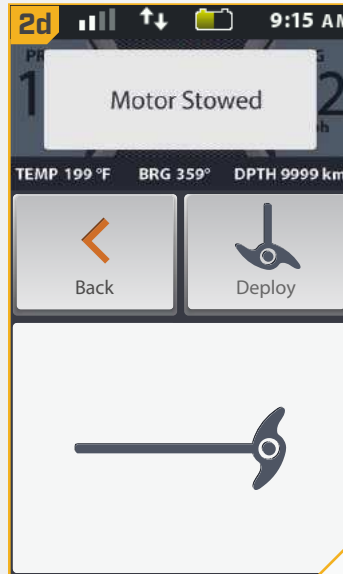

- e. The Ulterra motor will deploy. While the Motor is deploying, it is possible to pause the action. To pause the action, find the Pause  button and select it.
- f. To resume the Deploy action, select the Deploy  button.
- g. If the Motor continues, it will complete the deploy process and normal motor operation will follow.



QUICK STOW & DEPLOY

› Stowing the Motor with i-Pilot Link

1

- Press the Home  button.
- Scroll through the Content Area using either your finger or the Screen Navigation  button to find the Ulterra  button.
- Select the Ulterra  button using either your finger or by pressing the Ok  button to open the Ulterra Menu.

NOTICE: The Ulterra  button can only be found in the Content Area with the Home Control Buttons on i-Pilot Link systems on an Ulterra motor. The motor can only be stowed when it is currently deployed.





2

- Once in the Ulterra Menu, find the Stow  button and select it.

NOTICE: The Stow  button can only be found when the motor is deployed.

WARNING

As soon as the Stow  button is selected, the motor will automatically stow. Be sure the motor is clear from obstructions and has a clear path of travel. The Prop is disabled while the motor is being stowed to prevent accidental contact with the rotating propeller.

- The Ulterra motor will stow. While the Motor is stowing, it is possible to pause the action. To pause the action, find the Pause  button and select it.

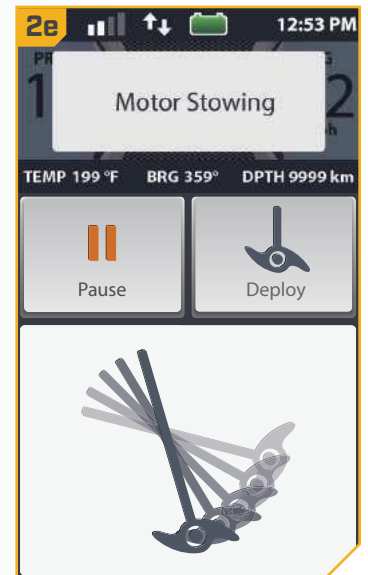

3

- f. To resume the Stow action, select the Stow  button.
- g. If the Motor continues, it will complete the Stow process and normal motor operation will follow.

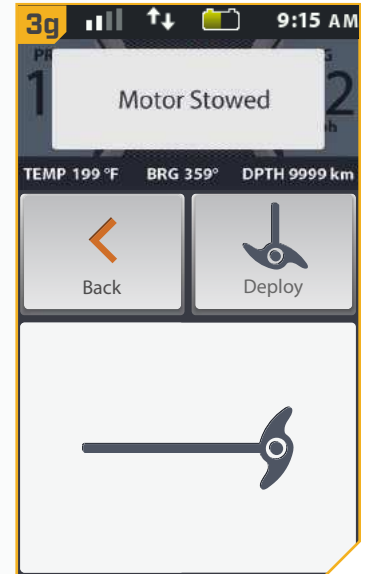
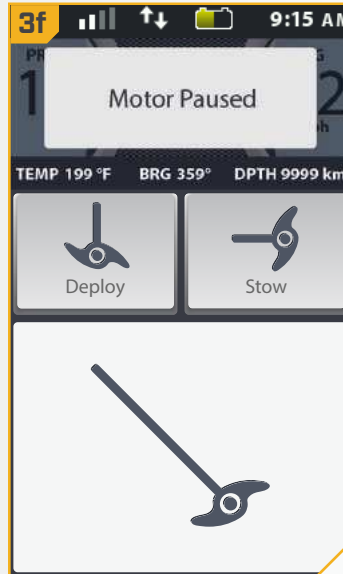

INSTALLING AN EXTERNAL TRANSDUCER

MOTOR ADJUSTMENTS >

> Installing an External Transducer

An external transducer is not included with your trolling motor. An external transducer can be installed onto motors that have Universal Sonar or motors that do not have a built in transducer. For more information on Universal Sonar, please visit minnkotamotors.com. Installing an external transducer is not recommended for motors with Built-in MEGA Down Imaging.

- 1
 - a. Mount the External Transducer according to directions provided with the transducer.
 - b. Leave enough slack in the Transducer Cable between the Lower Unit and Control Head to allow the motor to properly stow and deploy.
 - c. Use two tie wrap cables to secure the Transducer Cable to the Shaft just above the Lower Unit and just below the Control Head.
 - d. Run the Transducer Cable through the Coil Cord to the power supply.

CAUTION

Not following the recommended wire routing for the Universal Sonar and External Transducer Cables may cause damage to the product and void your product warranty. Take care to test the length and placement of cable to be sure that there is enough slack where needed and that cables are free of being entangled in moving parts. Routing the cables in any way other than directed may cause damage to the cables by being pinched or severed.

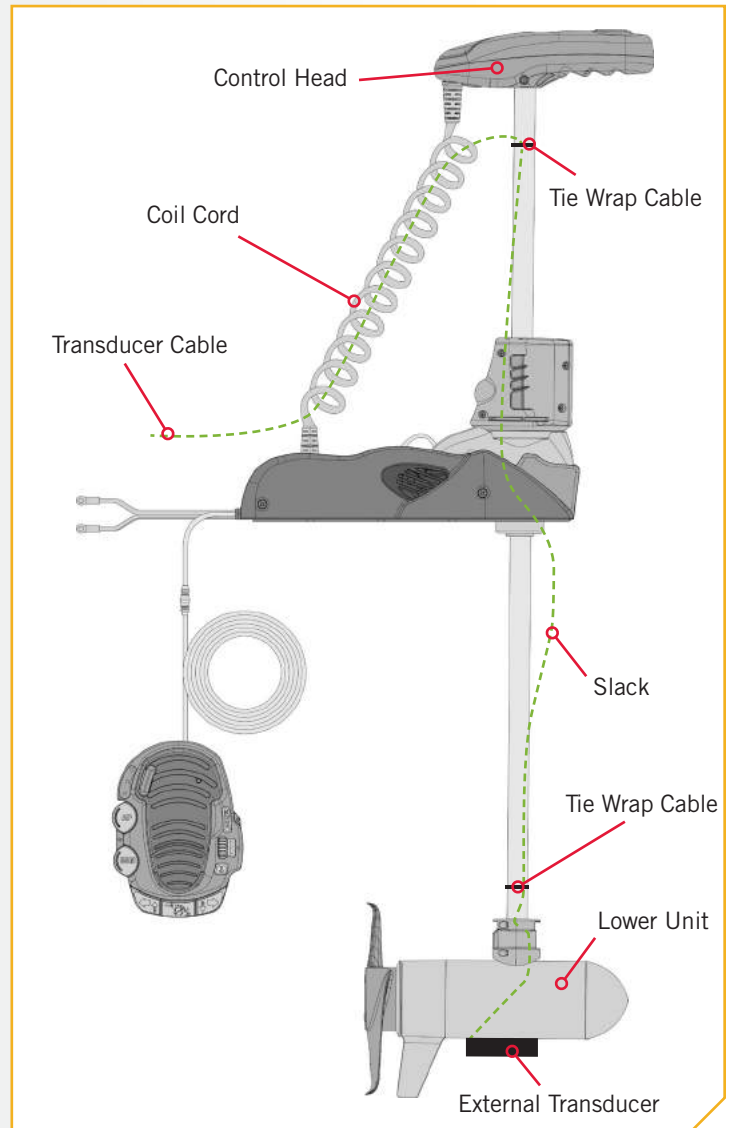

Changing the Prop Orientation

When the motor is mounted onto the boat, the orientation of the Prop may be changed to either Inboard or Outboard to accommodate different boat cover configurations. Complete the following steps to change prop orientation.

WARNING

When the motor is powered "off" while off the Motor Ramps, never turn the lower unit of the motor manually (by hand). This will affect the alignment of the motor and cause it to stow improperly.

- 1 a. Be sure the motor is connected to a power source and turn the motor "on".

WARNING

When stowing or deploying the motor, keep fingers clear of all hinges, pivot points and all moving parts. When stowing and deploying the motor, ensure that it doesn't contact the boat, trailer, or any other obstruction.

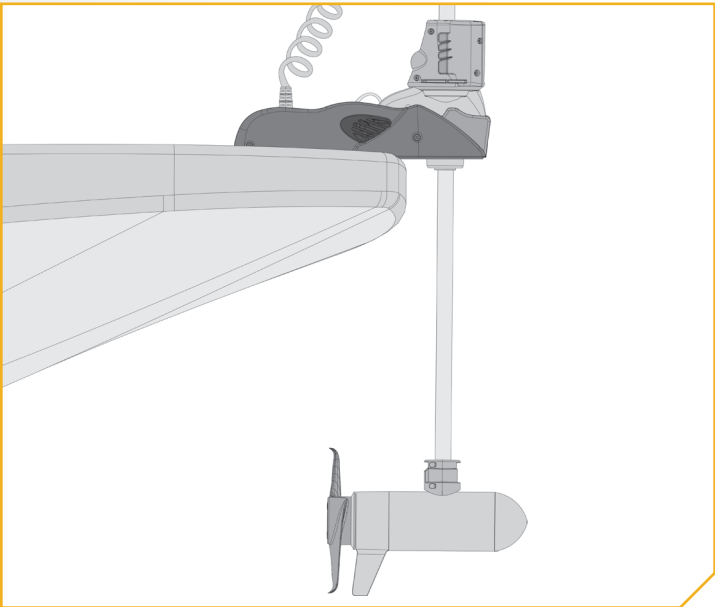

- 2 c. Turn the motor "off". Make sure the Power Cables from the battery are disconnected, or that the breaker, if equipped, is "off".

WARNING

Make sure the motor is mounted on a level surface and is not connected to a power source.

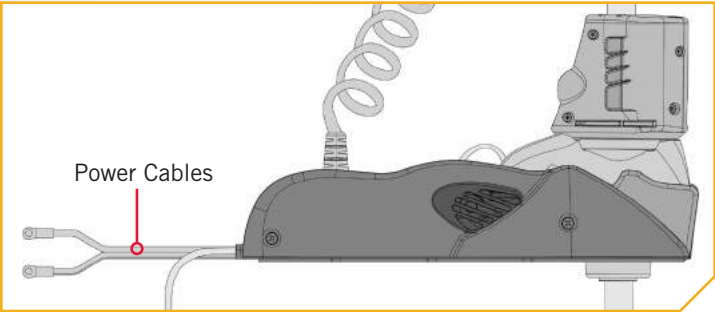

CHANGE THE PROP ORIENTATION

3

- d. Locate the Trim Release Handle on the Side of the Trim Housing. Grasp the Trim Release Handle and pull it out.



WARNING

When using the Trim Handle or moving the Trim Housing, keep fingers clear of all hinges, pivot points and all moving parts above and below the Trim Housing.

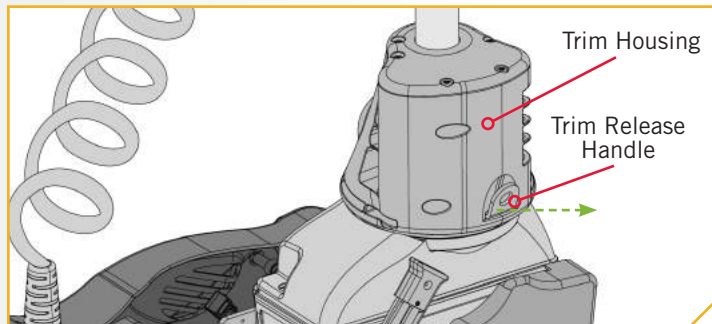

4



WARNING

When lifting the Trim Housing off the Steering Housing, power connections are exposed. Keep fingers and metal objects clear of exposed connections. The power from the connection is removed after 10 seconds once the connection is exposed.

- e. While holding the Trim Release Handle out, grasp the Trim Housing and Shaft and lift them up off the Steering Housing. Wait a minimum of 10 second holding it in this position.
- f. While holding Trim Housing and Shaft up, rotate them 180 degrees.

4e

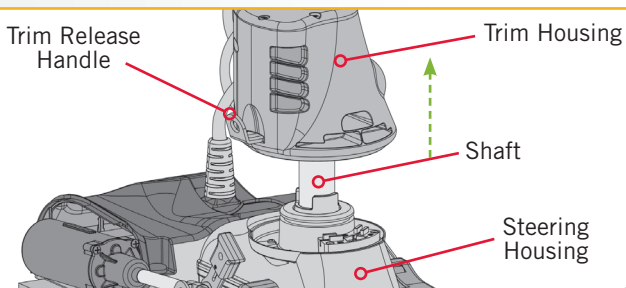

4f

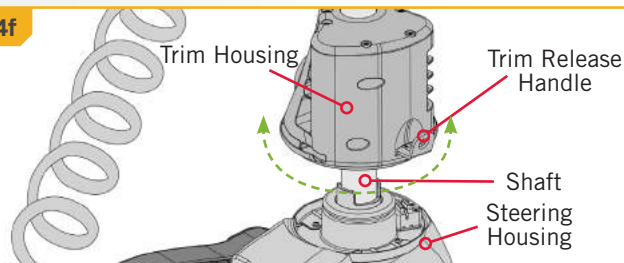

5

- g. The Trim Housing and Shaft may be turned either clockwise, or counterclockwise depending on if the motor is originally mounted on either the Port or Starboard side of the boat and the necessary accommodations that will be needed for each individual situation.

Outboard

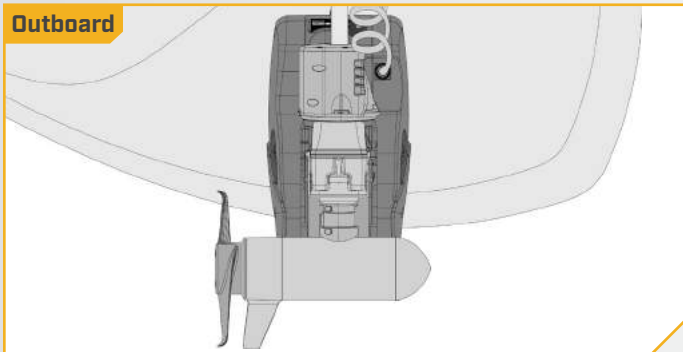

Inboard

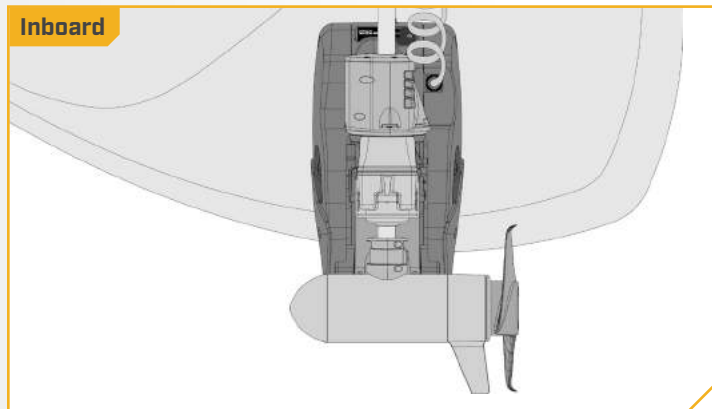

CHANGE THE PROP ORIENTATION

6

- h. Once in the proper orientation, lower the Trim Housing and Shaft onto the Steering Housing.
- i. Let the Trim Release Handle move back in place.

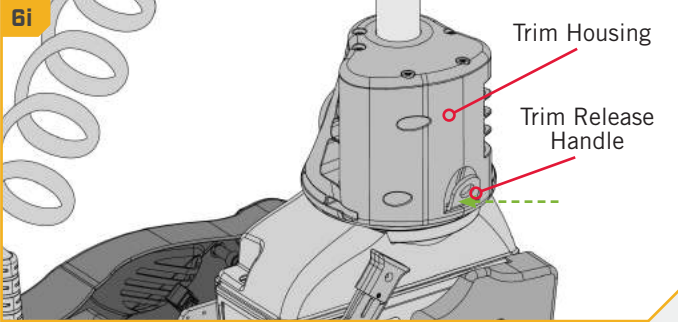

6h

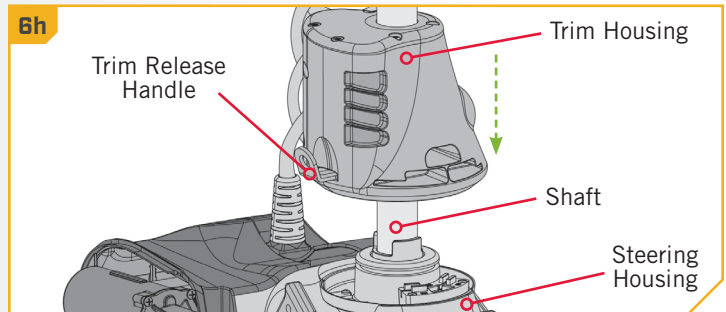

7

- j. Reconnect the Power Cables to the battery and make sure the breaker, if equipped, is turned "on". Turn the motor "on".
- k. Stow the motor using the Stow/Deploy Button on the Foot Pedal or using the i-Pilot or i-Pilot Link remote to check the orientation of the Prop.

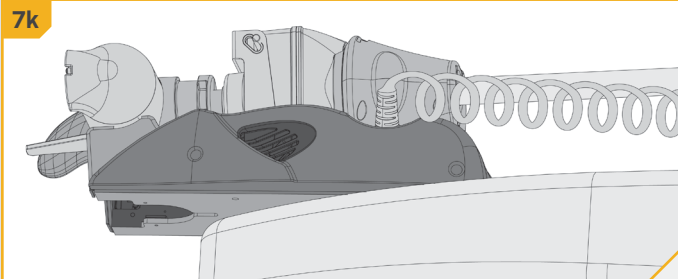

7j

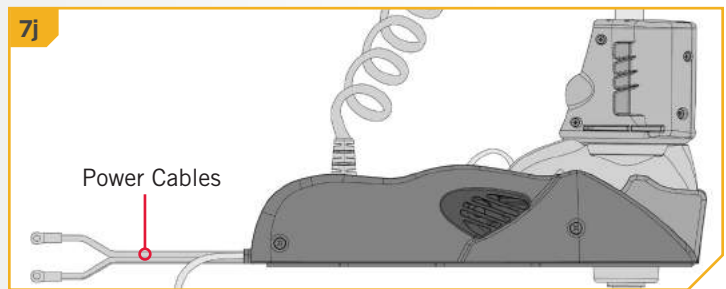

WARNING

When stowing or deploying the motor, keep fingers clear of all hinges, pivot points and all moving parts. When stowing and deploying the motor, ensure that it doesn't contact the boat, trailer, or any other obstruction.

ADJUSTING THE LIFT BELT

Adjusting the Lift Belt

The Lift Belt assists in Trimming the Lower Unit up and down. Periodically slack may appear in the Lift Belt along the Shaft of the motor. The screw that hold the tension on the Lift Belt may occasionally require small adjustments to maintain the tension on the belt.

1

- Locate the Socket Head Cap Screw on the Bottom of the Control Head. It can be found between the Coil Cord and Shaft. This is the screw that is adjusted to increase the tension on the Lift Belt.
- Using a 5/32" Allen Wrench, turn the Socket Head Cap Screw clockwise to tighten the Lift Belt.
- The screw should be tightened to 8 to 10 inch-lbs.

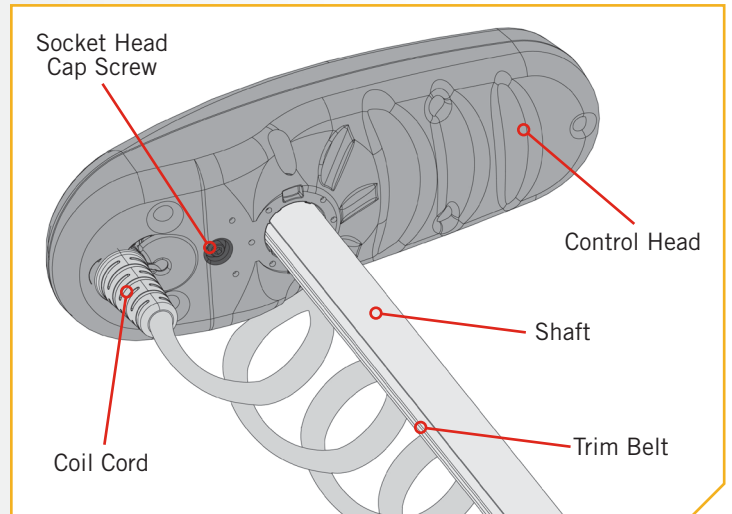

Greasing the Latch Pin and Power Tilt Motor Shaft

In order for the Ulterra to continue running at optimum performance, it is recommended that the Latch Pin and the Motor Shaft for the Power Tilt be greased every season. It is recommended to use a marine grade grease.

1

- Deploy the motor.
- Using a #3 Phillips Screwdriver, remove the Right Sideplate by removing the two screws that hold the sideplate in place. Removing the Right Sideplate will expose the Power Tilt and allow access to the Motor Shaft.
- Apply a marine grade grease to the Power Tilt Motor Shaft.
- Replace the Right Sideplate.

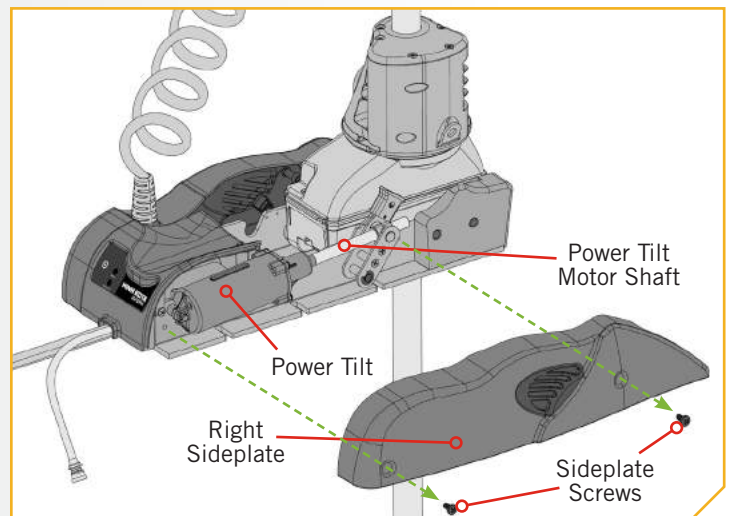

WARNING

When orientating the motor, keep fingers clear of all hinges, pivot points and all moving parts.

STOWING FROM THE ULTERRA MOTOR

2

- e. Stow the motor and locate the Latch Pin at the bottom of the Steering Housing.
- f. Apply marine grade grease to both ends of the Latch Pin to maintain optimal performance.

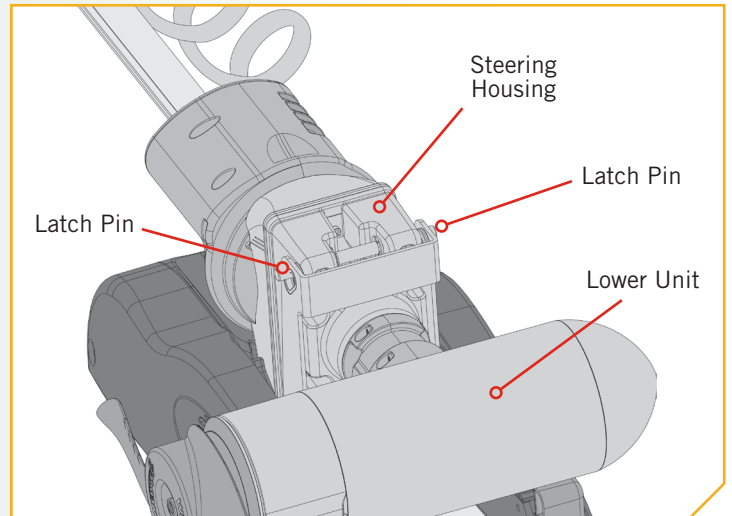

Stowing from the Ulterra Motor

In the unlikely event your i-Pilot or i-Pilot Link remote becomes non-functioning, you can stow the Ulterra from the base of the motor.

1

- a. Locate the Indicator Panel at the base of the Mount.
- b. Make sure that the motor is on by checking that the green LED next to the System Ready Indicator is on.
- c. Press and hold the Power Button located on the Indicator Panel for 10 seconds.
- d. The red and green LEDs next to the Status (red) and System Ready (green) Indicators will flash alternately, and the motor will begin to stow.

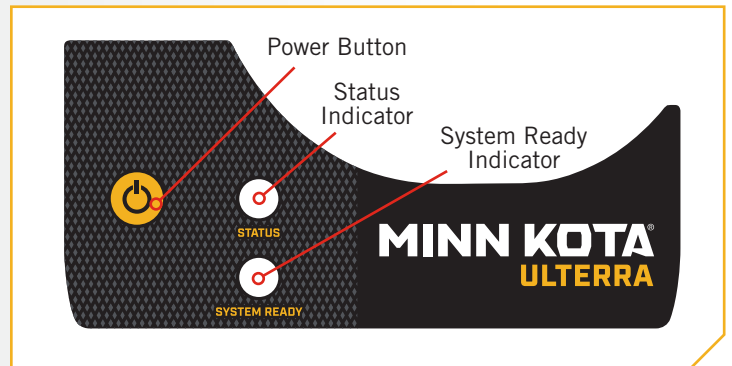

WARNING

During this procedure the motor will go into an automated sequence. Keep fingers clear of all hinges, pivot points and all moving parts. Ensure that the motor, or parts of the motor do not contact the boat, trailer, persons, or any other obstruction.

TRIM/STOW RESET PROCEDURE

Trim/Stow Reset Procedure

In the unlikely event Ulterra will not trim or stow, the following procedure will reset the motor and restore functionality. If Ulterra does not reset, repeat the procedure. If the second attempt fails, please contact your local authorized service center or call Minn Kota service at (800) 227-6433.

1

WARNING

During this procedure the motor will go into an automated sequence. Keep fingers clear of all hinges, pivot points and all moving parts. Ensure that the motor, or parts of the motor do not contact the boat, trailer, persons, or any other obstruction.

- a. Locate the Indicator Panel at the base of the Mount.
- b. Press and hold the Power Button located on the Indicator Panel to turn the motor off. Make sure that the motor is off by checking that the green LED light next to the System Ready Indicator is off.
- c. Press the Power Button until the green LED illuminates and the motor is turned on.
- d. Wait 3 seconds.

NOTICE: If the Lower Unit of the motor is trimmed within 6 inches of the Mount and the boat Hull is obstructing the motor's turning radius, manually turn the Control Head of the motor so that the Lower Unit is perpendicular to the Motor Ramps prior to beginning this procedure.

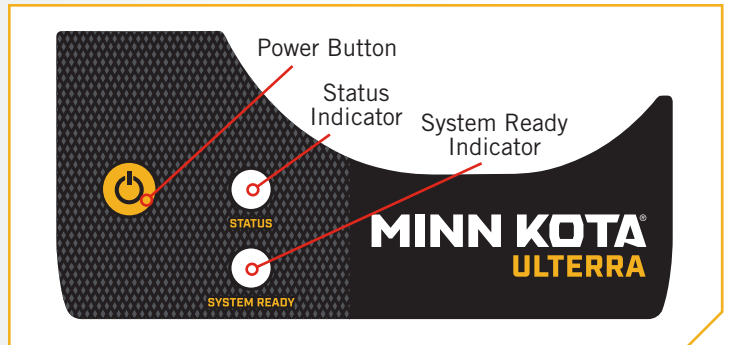

2

- e. Press the Power Button 3 times consecutively within a 2 second period.
- f. The red and green LEDs will flash continuously and the Ulterra will go through the following automated sequence:
 - The motor will position itself into the proper orientation.
 - The motor will automatically trim up to the Mount and then trim down approximately 6 inches.
 - The flashing red LED next to the System Ready Indicator will turn off, and the flashing green LED next to the Status Indicator will become solid green.

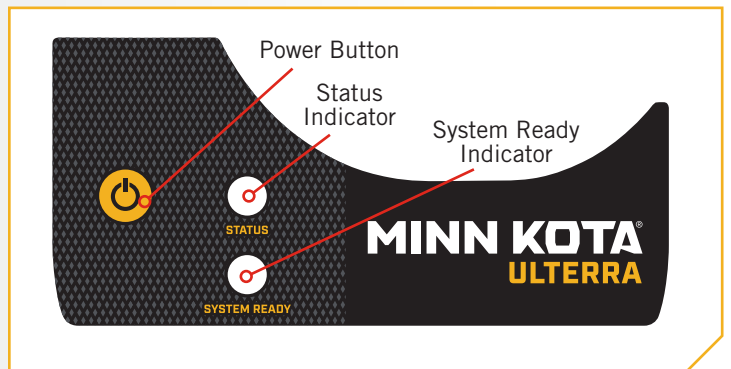

› Manually Stowing the Ulterra

In the unlikely event that the motor will not stow from either the i-Pilot or i-Pilot Link remote or the Foot Pedal, the following alternative stow methods should solve the issue:

1. Trim/Stow Reset Procedure
2. Stowing from the Ulterra Motor
3. If your batteries lose power to the level that the motor will not stow, the motor will most likely stall at a 45 degree angle. If this occurs, reengage power, deploy the motor, trim motor to its highest setting, and turn power off until batteries can be recharged. Once batteries are charged, attempt to stow motor again.

If all three alternative methods have been tried and the motor will still not stow, there is a method to manually stow the motor.

⚠ CAUTION

Once the motor has been manually stowed, it will be non-operational until it is manually reset by an authorized service center.

If a manual stow must be done, follow the instructions below:

- 1** a. While the motor is in the deployed position, use a #3 Phillips Screwdriver, to remove the Right Sideplate. Do this by removing the two screws that hold the sideplate in place.

⚠ WARNING

Moving parts can cut or crush. When using the Trim Handle or moving the Trim Housing, keep fingers clear of all hinges, pivot points and all moving parts. The Tilt Motor Shaft and Tilt Motor Bracket can create a shear point between the Base Extrusion. Use caution when the sideplate is removed and mechanical parts are in motion.

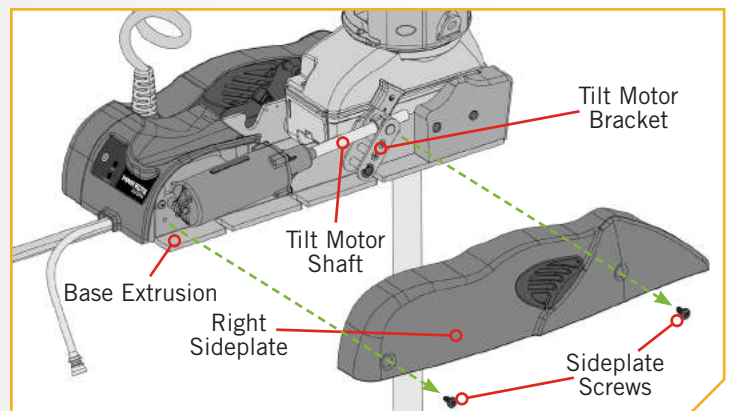

MANUALLY STOWING THE ULTERRA

2

- b. Using a #2 Phillips Screwdriver, loosen the screw on the Manual Tilt Knob.
- c. The Manual Tilt Knob holds two Metal Plates together. Using a Flat Blade Screwdriver pry up on the Manual Tilt Knob until it releases from the Metal Plates.

2b

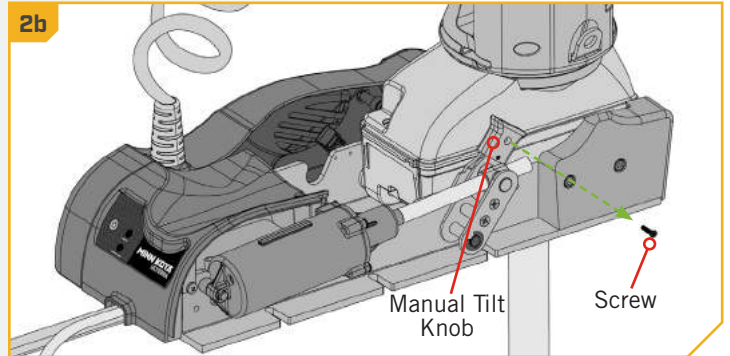

2c

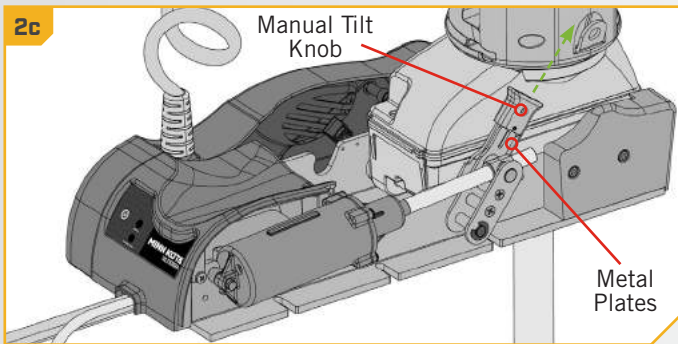

3

- d. Locate the Trim Release Handle on the Side of the Trim Housing. Grasp the Trim Release Handle and pull it out.

WARNING

When using the Trim Handle or moving the Trim Housing, keep fingers clear of all hinges, pivot points and all moving parts above and below the Trim Housing.

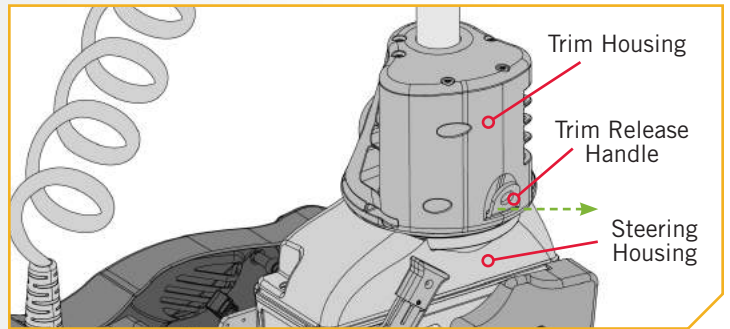

4

- e. While holding the Trim Release Handle out, grasp the Trim Housing and Shaft and lift them up off the Steering Housing.
- f. Lift up on the Trim Housing until Shaft and Trim Housing can be pulled up by hand.

WARNING

When lifting the Trim Housing off the Steering Housing, power connections are exposed. Keep fingers and metal objects clear of exposed connections. The power from the connection is removed after 10 seconds once the connection is exposed.

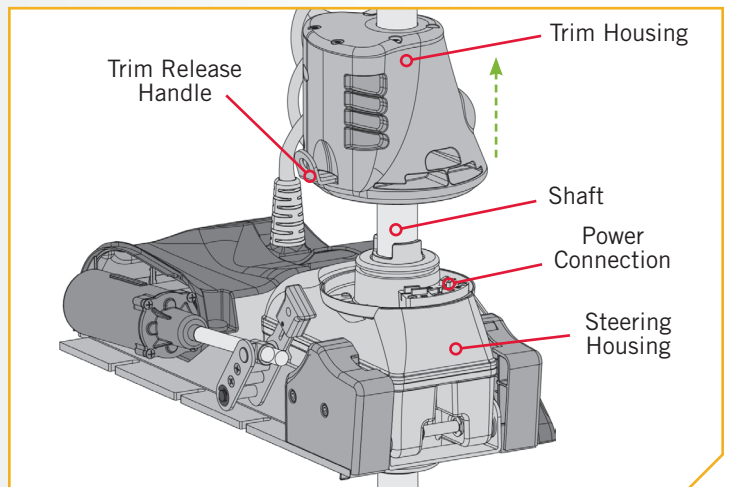

MANUALLY STOWING THE ULTERRA

5

- g. While the Trim Housing and Shaft are lifted up, release the Latch Pin Bracket.
- h. Lift the Trim Housing, Shaft and Lower Unit up, and rotate it.
- i. Pull the Lower Unit onto the Mount Ramps.

5h

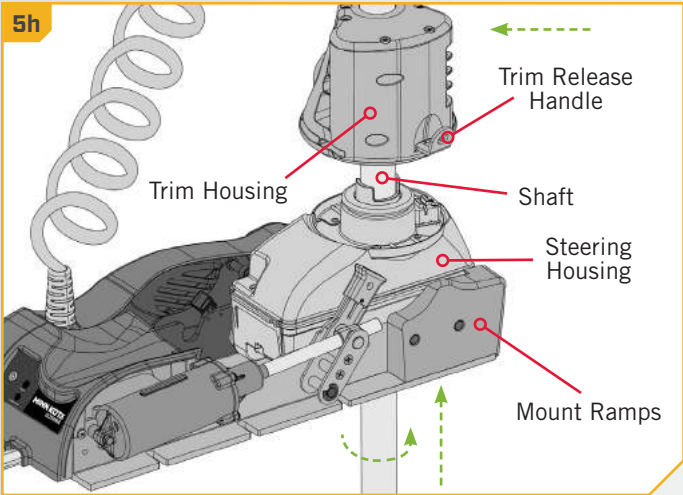

5g

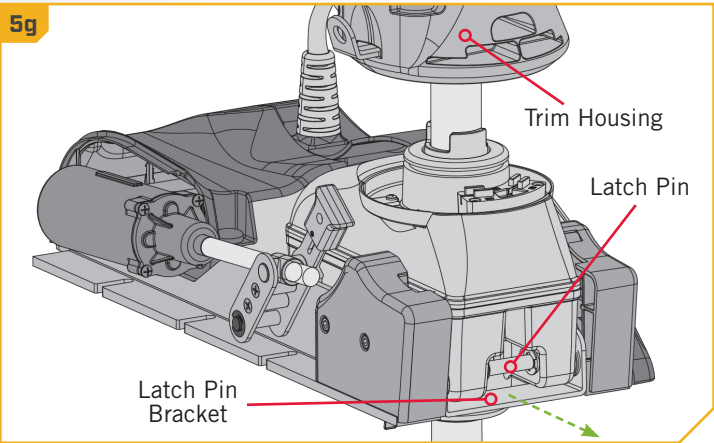

5i

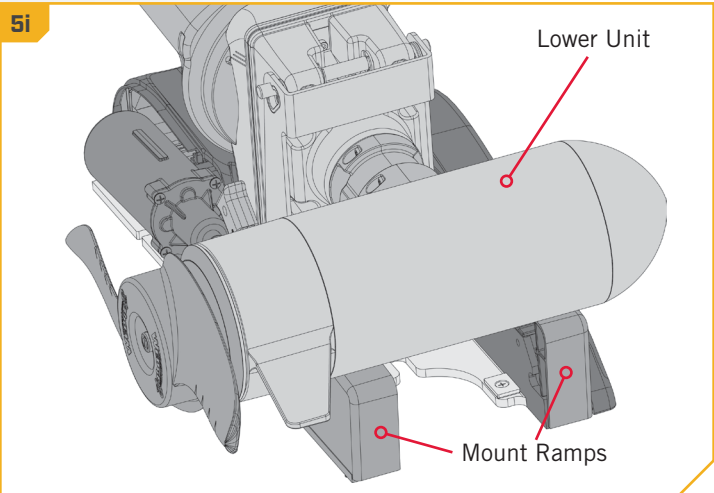

6

- j. Secure the Lower Unit onto the Mount Ramps using the Emergency Strap that was provided with the motor. The D-ring on the Emergency Strap can be hooked into the Base Extrusion below the sideplate that was removed.
- k. With the D-ring secured, wrap the Emergency Strap around the Lower Unit and secure it to itself. The Emergency Strap should be pulled tight enough that the Lower Unit rests securely on the Mount Ramps.

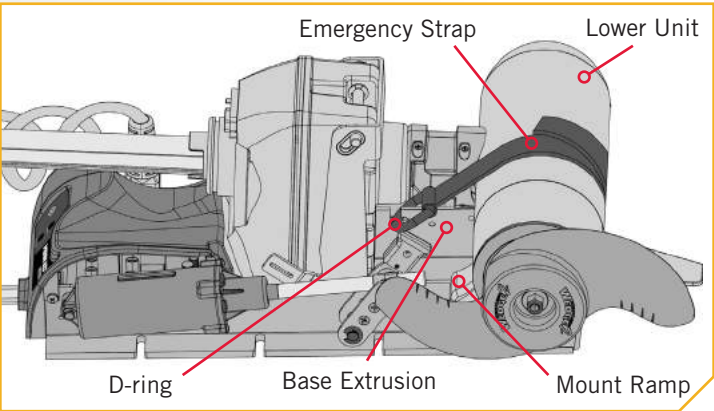

MANUALLY STOWING THE ULTERRA

7

- I. While the motor is in the stowed position, use a #3 Phillips Screwdriver, to replace the Right Sideplate, if desired. Do this by replacing the two screws that hold the sideplate in place.

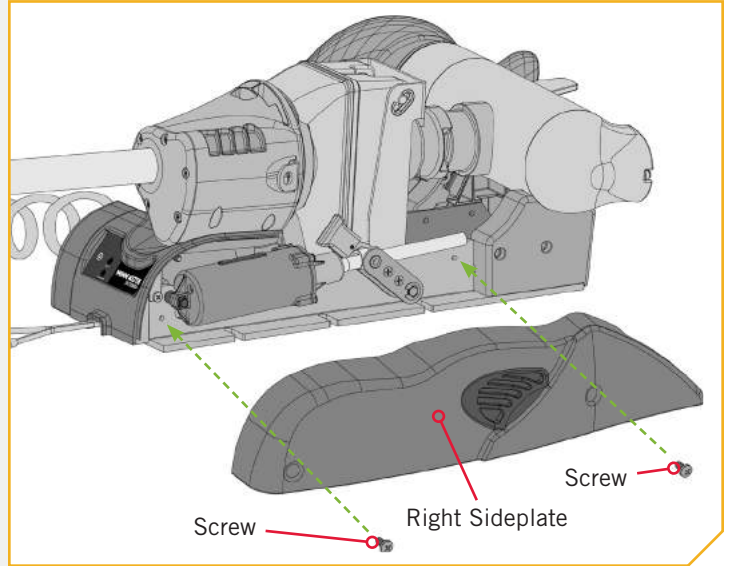

USING THE FOOT PEDAL

CONTROLLING SPEED & STEERING WITH THE FOOT PEDAL

The Foot Pedal is used to operate the motor, and controls on the Foot Pedal are easy to operate. The motor can also be controlled by an i-Pilot or i-Pilot Link remote, as well as any compatible Minn Kota remote. Please refer to the [i-Pilot](#), [i-Pilot Link](#) or compatible remote manual on how the remote controls the motor.

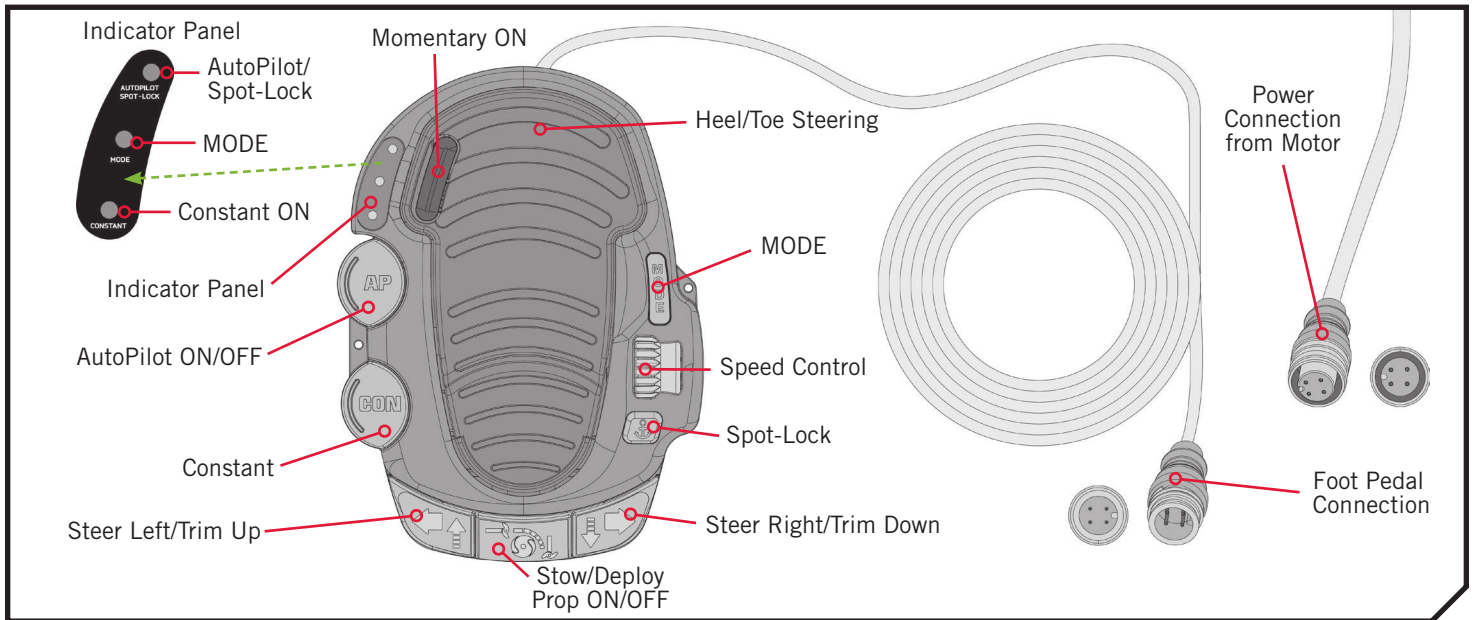

MODES

The Ultra Foot Pedal has two modes of operation, Normal Mode and Ulterra Mode. To alternate between the Modes, press the MODE button located on the right side of the Foot Pedal, just above the Speed Control knob. The amber light on the Indicator Panel illuminates on and off when toggling between modes. The Indicator Panel is located on the top, left side of the Foot Pedal. Switching between the modes of operation affects the functionality of the three buttons at the bottom of the Foot Pedal. These buttons include:

1. Steer Left/Trim Up button
2. Stow/Deploy/Prop ON/OFF button
3. Steer Right/Trim Down button

› Normal Mode

When in Normal Mode, the buttons at the bottom of the Foot Pedal function to Steer Left, Steer Right, and turn the Prop ON/OFF. The amber light  on the Indicator Panel will not be illuminated when in Normal Mode.

› Ulterra Mode

When in Ulterra Mode, the buttons at the bottom of the Foot Pedal function to Trim Up, Trim Down, and Stow/Deploy. The amber light  on the Indicator Panel will be illuminated during Ulterra Mode.

FOOT PEDAL OPERATION

› Motor Speed

The Speed Control knob is located on the right side of the Foot Pedal between the MODE and Spot-Lock buttons. Turn the Speed Knob forward to increase speed and backwards to decrease speed. The Speed Control knob can be set in a range from 0 to 10, and can be adjusted in both Normal and Ulterra Modes. Speed can also be adjusted using the remote.

WARNING

Practice proper ergonomics when operating the foot pedal to prevent injury.



FOOT PEDAL OPERATION





WARNING

You are responsible for the safe and prudent operation of your vessel. We have designed Ulterra to be an accurate and reliable tool that will enhance boat operation and improve your ability to catch fish. This product does not relieve you from the responsibility for safe operation of your boat. You must avoid hazards to navigation and always maintain a permanent watch so you can respond to situations as they develop. You must always be prepared to regain manual control of your boat. Learn to operate your Ulterra in an area free from hazards and obstacles.

Spot-Lock

The Spot-Lock button  is located on the bottom, right side of the Foot Pedal and is labeled with an anchor symbol. When the Spot-Lock button is pressed, the location of the motor is recorded to a temporary Spot-Lock location. The blue light  next to the Spot-Lock label on the Indicator Panel is illuminated when Spot-Lock is engaged. To engage Spot-Lock press the Spot-Lock button, to disengage, press the Spot-Lock button again. When engaging Spot-Lock, a tone will be emitted. When disengaging Spot-Lock with the Spot-Lock button, no tone will be emitted. Steering the motor with the Foot Pedal or adjusting the speed using the Speed Knob will cancel Spot-Lock and a High-Low, High-Low, High-Low tone will be emitted. Spot-Lock can be engaged in Normal and Ulterra Modes. Spot-Lock can also be controlled with the remote. For more specific directions on how to use Spot-Lock, please refer to either the [i-Pilot](#) or [i-Pilot Link](#) Manual.



› Steer Right/Steer Left

The Steer Right  and Steer Left  buttons are located at the bottom of the Foot Pedal. They function to steer right and left when the Foot Pedal is operating in Normal Mode. The amber light  on the Indicator Panel will not be illuminated when in Normal Mode. Holding the Steer Right or Steer Left buttons down will continue to steer the motor to the left or right. Small steering changes of less than one degree can be made by quickly tapping the Steer Right and Steer Left buttons.

CAUTION

The steering system is designed to turn your motor 360 degrees. Be careful to avoid over-wrapping the Coil Cord around the trolling motor Shaft.



› Trim Down/Trim Up

The Trim Down  and Trim Up  buttons are located at the bottom of the Foot Pedal. The Trim Down button trims the motor down and the Trim Up button trims the motor up. Their function is to trim the motor when the Foot Pedal is operating in Ulterra Mode. The amber light  on the Indicator Panel will be illuminated during Ulterra Mode.



WARNING

When trimming the motor, keep fingers clear of all hinges, pivot points and all moving parts. When stowing and deploying the motor, ensure that it doesn't contact the boat, trailer, or any other obstruction.

› Prop ON/OFF

The Prop ON/OFF  button is located in the middle, at the bottom of the Foot Pedal. It functions to turn the Prop on and off when the Foot Pedal is operating in Normal Mode. The amber light  on the Indicator Panel will not be illuminated when in Normal Mode. The Prop will turn on when pressure is applied and turn off when pressure to the button is removed.

› Stow/Deploy

The Stow/Deploy  button is located in the middle, at the bottom of the Foot Pedal. It functions to stow and deploy the motor when the Foot Pedal is operating in Ulterra Mode. The amber light  on the Indicator Panel will be illuminated during Ulterra Mode. To stow the motor, when it is deployed,

WARNING

When stowing or deploying the motor, keep fingers clear of all hinges, pivot points and all moving parts. When stowing and deploying the motor, ensure that it doesn't contact the boat, trailer, or any other obstruction.





press the Stow/Deploy button. To deploy the motor, when it is stowed, double press the Stow/Deploy button. When stowing and deploying the motor, it automatically disables the operational function of the Foot Pedal or paired remote. "Motor Stowed" or "Motor Deploying" will be displayed on the screen of any applicable remote while the specific action is occurring. The Prop is also disabled when the motor is stowed and deployed.

WARNING



When the motor is being transported, it is important to always stow the Motor and make sure it is locked in place. A secure stow holds the motor in place during transportation when it is subject to high levels of shock and vibration. Failure to stow the motor may result in injury or damage to the unit.

› **Constant**

The Constant button  is located on the left side of the Foot Pedal, towards the bottom, right below the AutoPilot button. It functions to toggle the motor between Constant Motor Operation and Momentary Motor Operation. The green light  on the Indicator Panel will be illuminated when the motor is in Constant Motor Operation. In Constant Mode, the propeller will continually run, regardless of whether or not force is being applied to the Momentary button or Prop ON/OFF button. While in Constant Motor Operation, the propeller will run continuously at the speed set by the Speed Control knob, or by the i-Pilot or i-Pilot Link remote.

If a propeller encounters an obstruction while either in Momentary or Constant Mode, while the propeller is running, the increased electrical current being generated by the obstruction will signal the motor to decrease the power to the propeller to prevent damage. If the current overload is detected for more than 20 seconds, the prop will be disabled to prevent damage to the motor. In this event, the operator can turn the prop back on after being sure that the obstruction has been cleared.

› **AutoPilot**

The AutoPilot  button is located in the middle, on the left side of the Foot Pedal. Pressing the AutoPilot button toggles the feature on and off. The red light  on the Indicator Panel is illuminated when this feature is engaged. By default AutoPilot Mode is determined by the remote when AutoPilot is initiated from the Foot Pedal. AutoPilot can be used in both Standard and Ulterra Modes. AutoPilot can also be controlled using the remote. For more specific directions on how to use AutoPilot, please refer to either the [i-Pilot](#) or [i-Pilot Link Manual](#).

› **Momentary**

In Momentary Motor Operation, the propeller will only run while downward force is applied to the Momentary button. The Momentary button is on the Toe End of the Heel/Toe Steering pedal. Applying downward pressure to the Momentary button will turn the propeller on. The motor will then run at the speed set by the Speed Knob. Removing downward force to the Momentary button will turn the propeller off. No indicator light is associated with the Momentary button. The Momentary button functions very similar to the Prop ON/OFF button, but works in both Normal and Ulterra Modes.

› **Heel/Toe Steering**

Push the Toe End of the Foot Pedal down to turn right and push the Heel End of the Foot Pedal down to turn left. The position and direction of the Control Head directly corresponds to the position of the motor. You must use your foot on the pedal to control the steering direction during manual operation. The direction of the motor can also be controlled with the remote. Heel/Toe Steering functions the same Normal Mode and Ulterra Mode.

NOTICE: The motor will not auto correct to drive straight when it encounters an obstruction.

STOWING AND DEPLOYING THE MOTOR WITH THE FOOT PEDAL

FOOT PEDAL ADJUSTMENTS >

STOWING AND DEPLOYING THE MOTOR WITH THE FOOT PEDAL

Use the following procedure to stow and deploy the motor. Keep in mind that if your motor is stalling at a 45-degree angle when attempting to stow, this indicates that batteries are too low to fully stow the motor. If this occurs, reengage power, deploy the motor, trim the motor to its highest setting, and turn power off until batteries can be recharged. Once batteries are charged, attempt to stow motor again.



- 1
 - a. Locate the Indicator Panel at the base of the Mount.
 - b. Make sure that the motor is on by checking that the green LED next to the System Ready Indicator is on.

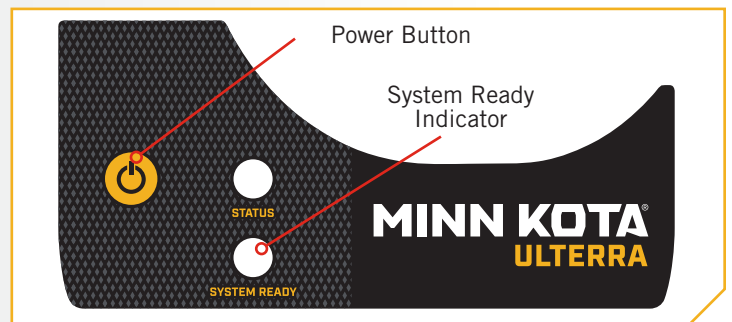

- 2
 - c. On the Foot Pedal, press the Mode Button until the amber LED in the center of the Indicator Panel on the Foot Pedal is illuminated. This puts the Foot Pedal in Ultrerra Mode.

NOTICE: You can only stow and deploy your motor while in Ultrerra mode.

- 2
 - d. To deploy the motor, when it is stowed, double press the Stow/Deploy button. To stow the motor, when it is deployed, press the Stow/Deploy button.

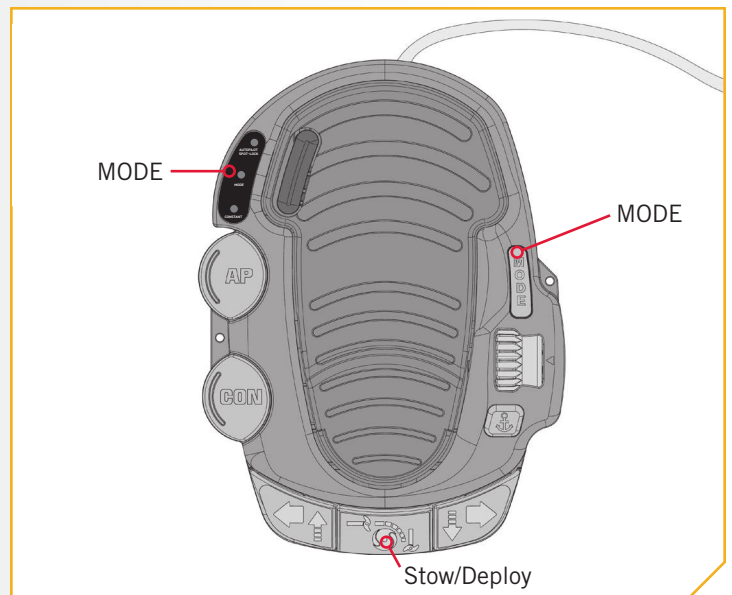

NOTICE: The deploy sequence can be stopped at any time pressing the stow/deploy button. The stow sequence can be stopped at any time by pressing either trim button or the stow/deploy button.

WARNING

When stowing or deploying the motor, keep fingers clear of all hinges, pivot points and all moving parts. When stowing and deploying the motor, ensure that it doesn't contact the boat, trailer, or any other obstruction.

ADJUSTING THE DEPTH OF THE MOTOR (TRIM) WITH THE FOOT PEDAL

ADJUSTING THE DEPTH OF THE MOTOR (TRIM) WITH THE FOOT PEDAL

Once the boat is on the water, it may be necessary to adjust the trim of the lower unit up or down to achieve an optimum depth for motor performance. When setting the depth of the motor, be sure the top of the motor is submerged at least 12" below the surface of the water to avoid churning or agitation of surface water. There will be times when you will need to move your motor up or down depending on how your boat is responding. You can trim up to avoid hitting underwater objects and you can trim down if your prop is coming out of the water. If your motor is equipped with either i-Pilot, or i-Pilot Link, please refer to either the i-Pilot, or i-Pilot Link Owner's Manual to learn how to adjust the trim with the corresponding remote.



When trimming the motor using either a remote or the Foot Pedal, the motor is programmed to operate safely and limit prop rotation when it is within certain limits. The prop will temporarily stop while trimming the motor and resume once trimming is stopped. Trim limits are in place to avoid damage to the unit. An upper trim limit is set 12" from the bottom of the motor mount to the center of the motor. A lower trim limit is set approximately 1.5" from the bottom of the control head to the trim housing. A prop lockout region, defined as 17" from bottom of motor mount to center of motor, is used to eliminate the possibility of the motor contacting the boat hull. All functions with the exception of manual steer and track record are canceled upon trimming into this region.

1

- a. On the Foot Pedal, press the MODE button until the amber LED in the center of the Indicator Panel on the Foot Pedal is illuminated. This puts the Foot Pedal in Ulterra Mode.

NOTICE: You can only trim your motor while in Ulterra Mode.

WARNING

When trimming the motor, keep fingers clear of all hinges, pivot points and all moving parts.

- b. To trim the motor up, press the Trim Up button located on the bottom, left of the Foot Pedal.
- c. To trim the motor down, press the Trim Down button located on the bottom, right of the Foot Pedal.

NOTICE: Please be sure the top of the motor is submerged at least 12" below the surface of the water to avoid churning or agitation of surface water.

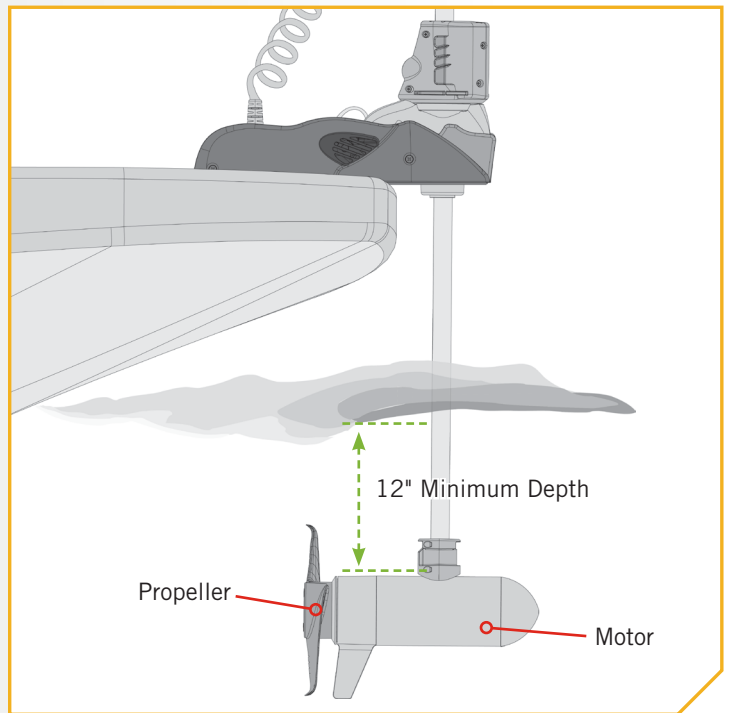

SERVICE & MAINTENANCE

PROPELLER REPLACEMENT

TOOLS AND RESOURCES REQUIRED >

- 9/16" Open End Wrench
- Flat Blade Screwdriver

INSTALLATION >

- Disconnect the motor from all sources of power prior to changing the propeller.
 - Hold the propeller and loosen the Prop Nut with a pliers or a wrench.
 - Remove the Prop Nut and Prop Washer.

NOTICE: If the Drive Pin is sheared or broken, you will need to hold the shaft stationary with a flat blade screwdriver pressed into the slot on the end of the shaft while you loosen the Prop Nut.

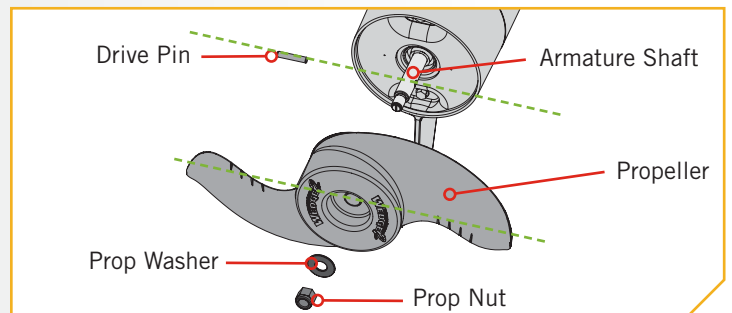

CAUTION

Disconnect the motor from the battery before beginning any prop work or maintenance.

- Turn the old prop to horizontal and pull it straight off. If drive pin falls out, push it back in.

CAUTION

If the prop does not readily slide off, take care to not bend the Armature Shaft while removing the prop by pulling the prop evenly off the Armature Shaft.

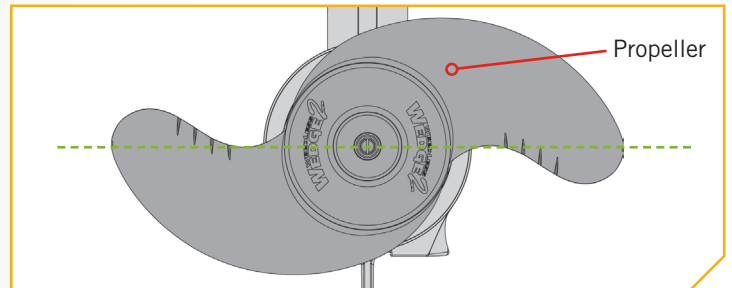

- Align the new Propeller with the Drive Pin.
 - Install the Prop Washer and Prop Nut.
 - Tighten the Prop Nut 1/4 turn past snug at 25-35 in-lbs.

CAUTION

Do not over tighten as this can damage the prop.

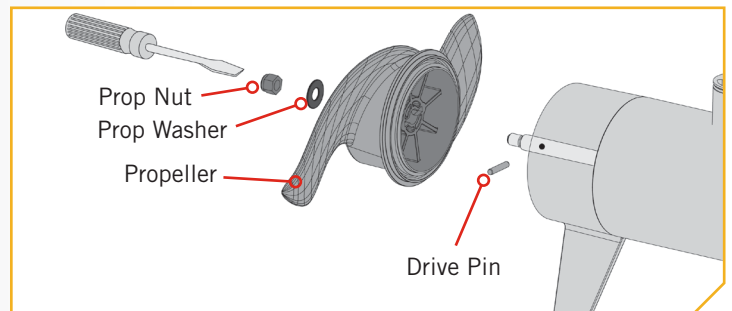



GENERAL MAINTENANCE

- After use, the entire motor should be rinsed with freshwater. This series of motors is not equipped for saltwater exposure.
- The composite shaft requires periodic cleaning and lubrication for proper retraction and deployment. A coating of an aqueous based silicone spray will improve operation.
- The propeller must be inspected and cleaned from weeds and fishing line after every use. Fishing line and weeds can get behind the prop, damage the seals and allow water to enter the motor.
- Verify the prop nut is secure each time the motor is used.
- To prevent accidental damage during transportation or storage, disconnect the battery whenever the motor is off of the water. For prolonged storage, lightly coat all metal parts with an aqueous based silicone spray.
- For maximum battery life recharge the battery(s) as soon as possible after use. For maximum motor performance restore battery to full charge prior to use.
- Keep battery terminals clean with fine sandpaper or emery cloth.
- The propeller is designed to provide weed free operation with very high efficiency. To maintain this top performance, the leading edge of the blades must be kept smooth. If they are rough or nicked from use, restore to smooth by sanding with fine sandpaper.
- Keep the Foot Pedal well dry and clean. Debris that gets in the Foot Pedal can cause interference of pedal operation. It is recommended to use compressed air to clean the foot pedal after each use.

TROUBLESHOOTING

1. Motor fails to run or lacks power:
 - Check battery connections for proper polarity.
 - Make sure the battery is charged.
 - Make sure terminals and wires are clean and corrosion free. Use fine sandpaper or emery cloth to clean terminals.
 - Check circuit protection devices.
 - Check battery water level. Add water if needed.
2. Motor loses power after a short running time:
 - Check battery charge. If low, restore to full charge, or replace.
3. You experience prop vibration during normal operation:
 - Remove and rotate the prop 180°. See removal instructions in the Propeller Replacement Section. Replace prop if worn.
4. Experiencing interference with your fish finder:
 - You may, in some applications, experience interference in your depth finder display. We recommend that you use a separate deep cycle marine battery for your trolling motor and that you power the depth finder from the starting/cranking battery. If problems still persist, call our service department at 1-800-227-6433.
5. Motor contacts an object while trimming causing an audible tone:
 - Reverse the direction of trimming to clear motor from obstruction.
6. Motor contacts an object while stowing causing an audible tone:
 - Reverse the current cycle by pressing the stow/deploy button to clear from obstruction.



TROUBLESHOOTING



7. Motor fails to trim:
 - Check main lift belt tension per the Adjustments section.
8. Motor fails to stow or deploy:
 - Check for obstructions preventing the motor from deploying or stowing.
 - Ensure that manual tilt knob is engaged. See the Emergency Stow Procedure section for details.
 - Check charge state of trolling motor batteries. If trolling motor battery icon on remote is flashing, battery charge is too low for operation.
9. Prop will not turn on:
 - Ensure batteries are sufficiently charged.
 - For safety reasons there is a prop lock out region (approx. 15” from mounting base to lower unit centerline). Ensure that the lower unit is not in this region.

NOTICE: For all other malfunctions, visit an Authorized Service Center. You can search for an Authorized Service Center in your area by visiting our Authorized Service page, found on-line at minnkotamotors.com, or by calling our customer service number at 800-227-6433.



ADVANCED TROUBLESHOOTING

The following advanced scenarios may help you troubleshoot your Ulterra motor.

CAUTION

Always wear safety glasses and gloves. Disconnect all power to the trolling motor before beginning any work or maintenance. Johnson Outdoors Inc. is not responsible for any damage due to improper rigging or installation. If you do not have the skills, experience and tools to perform the following maintenance and repairs, we recommend you seek the help of a Minn Kota Authorized Service Center. A list of Authorized Service Centers can be found at minnkotamotors.com/support/service-providers/locate. Contact the Service Department by email or, by dialing 800-227-6433.

› Case 1

The Ulterra motor does not turn on when the Power button on the control panel is pressed and released. The green “System Ready” and red “Status” LEDs do not light up.

CAUSE: Inadequate voltage, reversed polarity, or the switch/LED circuit board has come loose from the backside of the control panel.

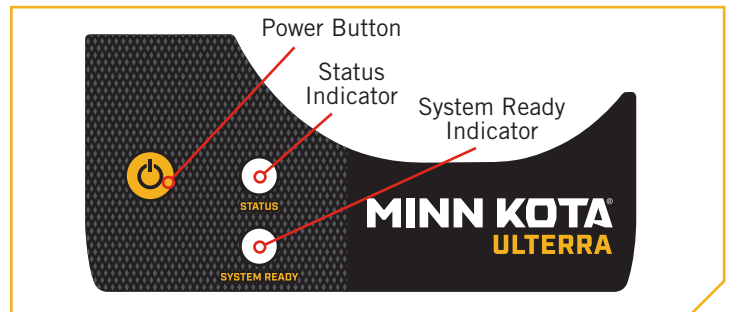

1 CORRECTIVE ACTION:

- Verify that the correct voltage is being supplied to the Ulterra motor (24-volts for Ulterra 80 and 36-volts for Ulterra 112) and that polarity has not been inadvertently reversed. Refer to the Battery and Wiring Installation section of this manual for additional details on wiring.
- If no problems are found with the voltage and power delivery/wiring system, then the Power switch/LED circuit board may have come loose from the control panel during shipment.
- To check for this remove the ¼-20 x ½” Phillips head screws that hold the motor side plates in place with a #2 or #3 screwdriver. (two screws each in the left and right side plates).

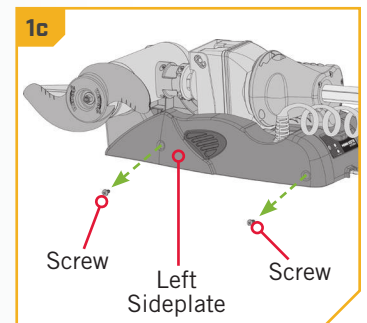
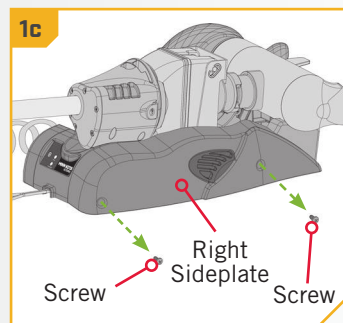

2

- With the side plates removed loosen the two small 10-32 x 3/8” Phillips head screws that hold the control panel cover in place. Lift up the cover as much as possible (due to the motor being stowed there is not much room for this) and look along the backside inner surface of the control panel cover to see if the Power switch/LED display is in place.

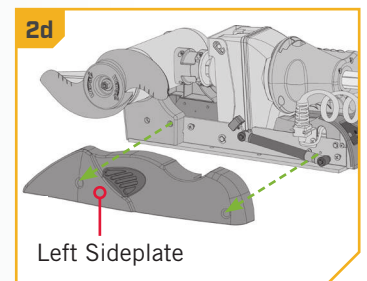
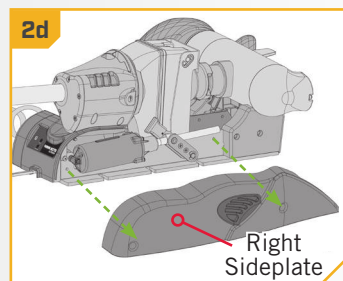

ADVANCED TROUBLESHOOTING

3

- e. If it has come loose, connect the motor to the appropriate voltage. The power can be switched ON by reaching in with a small object (a blade screwdriver, for example) and pressing down on the actuator of the Power switch. The green and red LEDs should light up and the Ulterra can then be deployed via the corded foot pedal or the remote in the normal manner.
- f. With the motor deployed (or partially deployed), the control panel cover assembly can be lifted up to expose the main control board assembly. The switch/LED board snaps into place on the inside surface of the control panel cover.
- g. When re-installing the switch align the actuator pin with the openings in the cover and push the board into position with the two catches, one on each side of the board, engage and hold the board in place.

NOTICE: if deploying the motor on the boat or benchtop the deploy sequence can be stopped by pressing the Stow/Deploy button.

NOTICE: Note the switch/LED circuit board is attached to the main control board by means of the ribbon lead.

4

- h. Reinstall the control panel cover and side plates to complete the repair.
- i. Test the Power switch ON/OFF function several times to insure proper switch retention. Test stow/deploy of the motor as you are able to on the boat or bench to confirm proper functionality.

NOTICE: To turn the motor off with the Power switch hold the switch button down for three seconds, the green and red LEDs should go out when this is done. Release the Power Button, wait about 3 seconds, and press and release the Power button. The green and red LEDs should come back on.

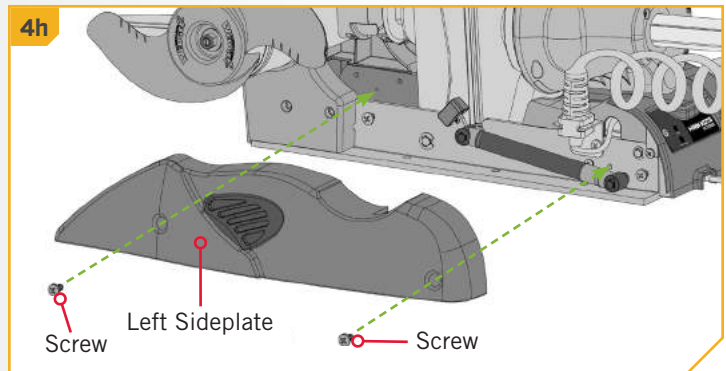
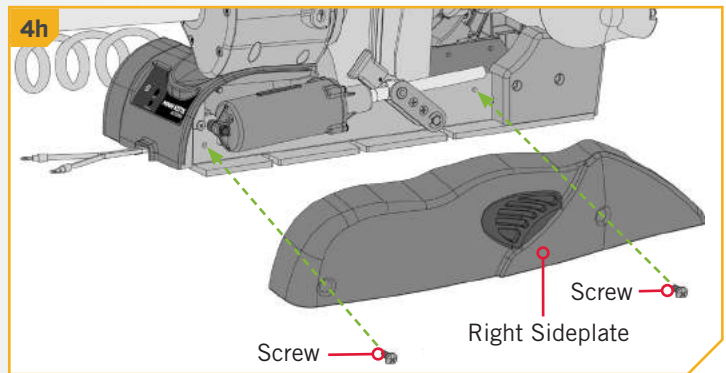

Case 2

Ulterra motor green “System Ready” and red “Status” LEDs come on when the Power button is pressed but immediately go off when the Power button is released.

CAUSE: Inadequate voltage is being supplied to the Ulterra motor. The Ulterra 80 is designed to operate on 24-volts, the Ulterra 112 is designed to operate on 36-volts. With low voltage the Ulterra motors will not stay on when the Power button is pressed and released or, if the green and red LEDs do stay on, they will go out when the command is sent to deploy or stow the motor.

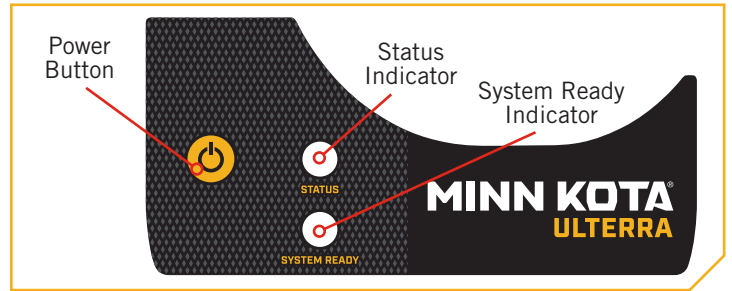

1 CORRECTIVE ACTION:

- a. The only option when this occurs is to provide adequate voltage to the motor. Check batteries for individual voltage values as well as the combined voltage across all the batteries in the series connected battery system. Then check the voltage at the motor battery positive (B+) and battery negative (B-) wires directly at the Ulterra motor to check for a voltage drop. Correct any wiring issues and/or recharge batteries, as required.

NOTICE: For more information refer to the Battery & Wiring Installation section of the manual. It may also be helpful to refer to the Motor Wiring Diagram.

Case 3

Ulterra motor will not deploy when the Stow/Deploy button on the foot pedal or the i-Pilot and i-Pilot Link remote is pressed. When troubleshooting, determine if an error tone is present or not and proceed to either the No Error Tone or Error Tone sections below.

NO ERROR TONE

If no error tone is noted when sending the deploy command:

CAUSE 1: The Ulterra owner/operator may not be pressing the Stow/Deploy button on the remote twice in quick succession, or if using the corded foot pedal, may not have the pedal in the Ulterra Mode and/or may not be pressing the Stow/Deploy button on the foot pedal twice in quick succession. To learn more about Foot Pedal Modes, please refer to the Using the Foot Pedal section of the manual.

1 CORRECTIVE ACTION:

- a. This is not a problem with the motor. It is designed to require two quick presses of the Stow/Deploy button to avoid accidental deployment of the motor. The only corrective action required is to advise that two button presses in quick succession are required to deploy the motor when using the i-Pilot remote or the corded foot pedal (foot pedal must be in “Ulterra” mode). To learn more about Foot Pedal Modes, please refer to the Using the Foot Pedal section of the manual.

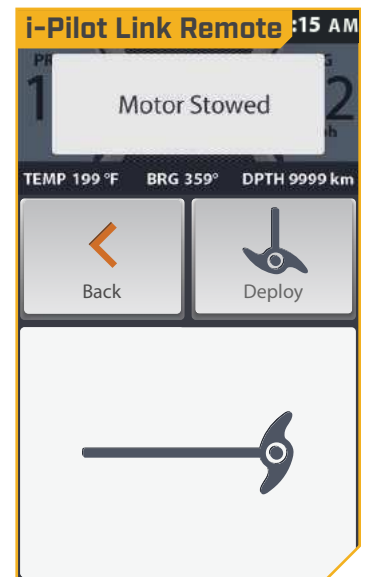
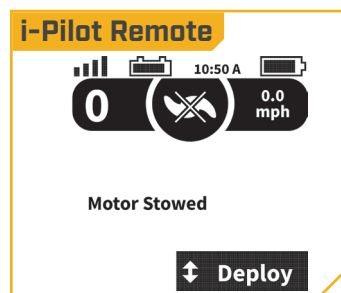
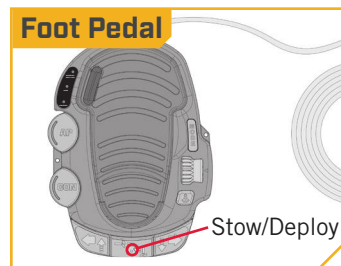

ADVANCED TROUBLESHOOTING

CAUSE 2: This malfunction is often found to be a result of unintentional/accidental damage to one or more of the three wires that connect each of the three Hall Effect Ulterra motor sensors to the main control board. The red, blue, and black wires going to each sensor are enclosed in black or gray mesh tubing running along both sides of the motor base extrusion. These wires can be accidentally damaged, pinched, or cut if care is not used to make certain that the motor (or Quick Release Plate) mounting bolts do not damage the wires when the bolts are tightened. The cutting of any of the sensor wires will cause the motor to be inoperative.

1 CORRECTIVE ACTION:

- a. Seek the help of a Minn Kota Authorized Service Center. A list of Authorized Service Centers can be found at minnkotamotors.com/support/service-providers/locate. Contact our Technical Service Department by email or, by dialing 800-227-6433.

ERROR TONE >

If an error tone is noted when sending the deploy command (this indicates a current limit issue):

CAUSE 1: The audible error tone when attempting to deploy the motor is an indication that something is restricting or preventing movement of the motor unit and shaft.

1 CORRECTIVE ACTION:

- a. To verify that the deploy issue is caused by something that is restricting or binding the motor shaft, we suggest removing the right, front motor ramp.
- b. If the motor does not deploy properly with the ramp removed: Contact your local authorized Minn Kota Service Center. Locate one online at minnkotamotors.com/support/service-providers/locate.
- c. If the motor deploys properly with the ramp removed this confirms a binding issue. Review the alternate causes below to identify the cause and corrective action to follow.

- **CAUSE:** Low or inadequate voltage to the motor/trim housing. **CORRECTIVE ACTION:** Verify that the wiring, connections, plug connections, and battery series connections are all clean and secure. Test the voltage at battery leadwires to ensure correct/adequate voltage is being supplied to the motor.
- **CAUSE:** A foreign object may be pinched between the steering housing and the aluminum mounting base extrusion. **CORRECTIVE ACTION:** Check to make certain that the power cable to the steering housing is not getting pinched between the housing and base.
- **CAUSE:** Dirt or other contaminants may be built up on the composite shaft causing the shaft to stick or bind rather than slide smoothly through the steering housing. **CORRECTIVE ACTION:** Thoroughly clean and wipe down the shaft with a silicone-rich, water-based spray such as Armor All or similar product.
- **CAUSE:** Verify the damper is installed correctly (leg down/toward the control board) and provides resistance to movement. **CORRECTIVE ACTION:** Remove the damper to test it.
- **CAUSE:** Inspect the Tilt Nut Bracket under the right side plate, verify that it is not bent and that the Tilt Nut does not show signs of damage. **CORRECTIVE ACTION:** Replace damaged parts.
- **CAUSE:** Watch the Tilt Motor when it is running, look for any wobble in the screw shaft as an indication it is bent. **CORRECTIVE ACTION:** Replace damaged parts.

NOTICE: You may need to assist the motor deploy sequence by pushing out on the head of the motor while sending a deploy command prior to cleaning.

› Case 4

Motor is deployed with the motor lower unit less than 14-15 inches below the aluminum base extrusion, it will not steer in either direction and the motor lower unit will not run.

CAUSE: Motor is in the “prop lockout region”. This feature is used to eliminate the chance of the motor lower unit or prop contacting the boat hull. For more information refer to the Adjusting Trim section of either the i-Pilot or i-Pilot Link manual. If using the Foot Pedal to trim the motor, it must be in Ulterra Mode. Learn more about Modes and Foot Pedal operation in the Using the Foot Pedal section of the manual.

1 CORRECTIVE ACTION:

- a. Trim the motor down to move the motor lower unit out of the lockout region.

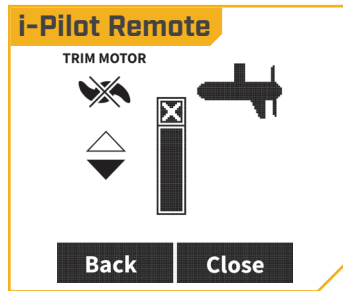
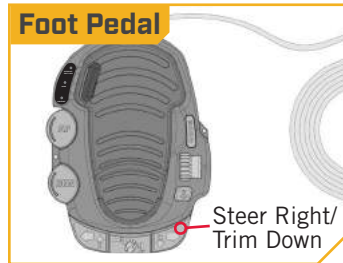

› Case 5

Ulterra motor does not properly position the motor lower unit in the Park Position when stowing. The motor lower unit is not turned to orient it at 90 degrees relative to the motor mounting base so that it lays horizontally when the Ulterra motor pulls the motor on to the motor ramps.

CAUSE: The Ulterra motor has been deployed, power switched OFF or disconnected, and the motor lower unit may have manually turned by hand, or rotated as a result of hitting an obstruction. When this occurs the Ulterra motor’s Park Position is lost and the motor lower unit will no longer be oriented properly when stowing.

1 CORRECTIVE ACTION:

- a. To correct this issue the Ulterra motor must be deployed in the usual manner. Refer to the owner’s manual on how to deploy the motor with the Foot Pedal or the corresponding manual for the i-Pilot or i-Pilot Link remote.

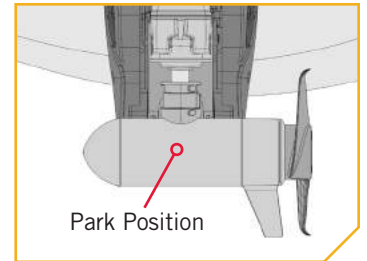
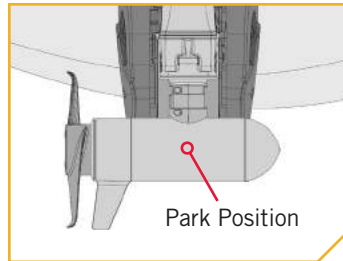

NOTICE: If the motor was stowed with the prop pointing up or down, you may need to depress the button on the left front motor ramp to deploy the motor. Release that button when the motor starts to deploy.

ADVANCED TROUBLESHOOTING

2

- b. Send a command to stow the motor via the remote or Foot Pedal. Allow the Ultrerra motor to steer the lower unit, raise straight up, rotate the shaft and motor assembly into the horizontal/stow position, then you must STOP the stow sequence by pressing the Stow/Deploy button before the Ultrerra starts to pull the lower unit on to the motor ramps.

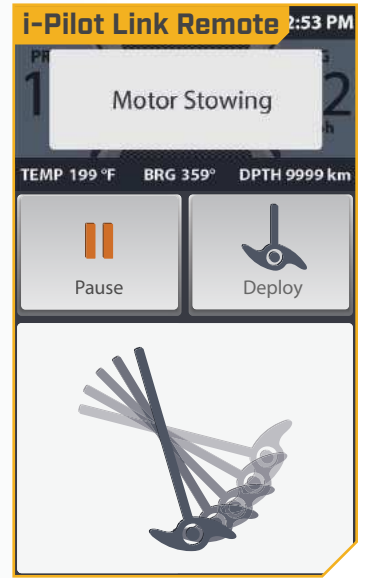
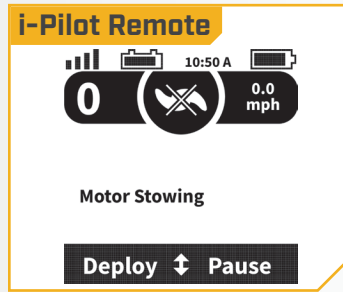
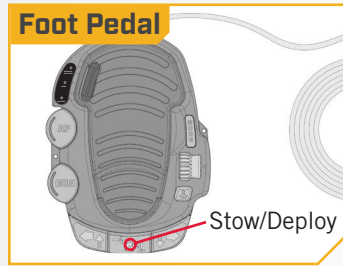

3

- c. At this point, turn the Ultrerra OFF by pressing and holding the Power button on the Indicator Panel about three seconds until the green System Ready LED turns off.
- d. Wait about five seconds, then manually rotate the motor lower unit into the Park Position by grasping and turning either the lower unit or the control box head. The motor should be positioned so that it is laying horizontally at 90 degrees to the mounting base with the prop to the left or right (per your preference).
- e. Turn the power back on at the control panel and stow/deploy the motor to test and confirm that the Park Position has been reset correctly. Repeat this procedure, if necessary, to tweak the Park Position.

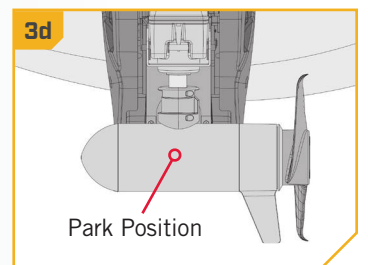
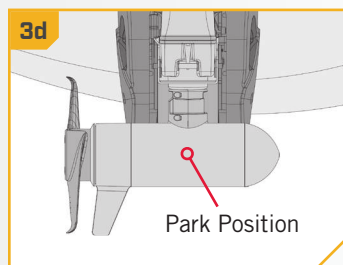
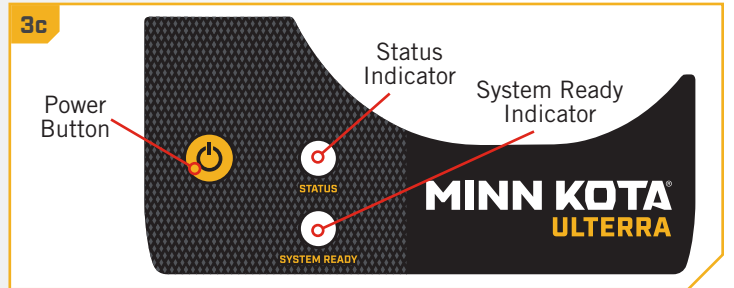

Case 6

The Ultrerra motor does not rotate into the horizontal position when stowing, or the vertical position when deploying, at the appropriate time. During the stow sequence the motor lower unit should come straight up and begin to rotate into the horizontal position when the lower unit is about twelve (12) to thirteen (13) inches below the aluminum base extrusion. During the deploy sequence the motor lower unit should extend about five (5) to six (6) inches out from the steering housing and then begin to rotate into the vertical position.

CAUSE: The trim module has lost its position count and needs to be reset.



1

CORRECTIVE ACTION:

- a. Refer to the Trim/Stow Reset Procedure in this manual.

NOTICE: To do the Trim/Stow Reset Procedure, the motor MUST be in the deployed position, with the motor and shaft assembly vertical and the latch pin in the steering housing engaged into the aluminum base extrusion catches.



FOR FURTHER TROUBLESHOOTING AND REPAIR



FOR FURTHER TROUBLESHOOTING AND REPAIR

We offer several options to help you troubleshoot and/or repair your product. Please read through the options listed below.



Buy Parts Online

You can buy parts on-line directly from our website at minnkotamotors.com. Orders confirmed by 12 Noon Central Time, with Overnight Shipping selected, should ship the same business day if the parts are in stock. All other orders should ship within the next 3 business days, depending on the shipment method chosen, and if the parts are in stock.



Frequently Asked Questions

We have FAQs available on our website to help answer all of your Minn Kota questions. Visit minnkotamotors.com and click on “Frequently Asked Questions” to find an answer to your question.



Call Us (for U.S. and Canada)

Our consumer service representatives are available Monday – Friday between 7:00 a.m. – 4:30 p.m. CST at 800-227-6433. If you are calling to order parts, please have the 11-character serial number from your product, specific part numbers, and credit card information available. This will help expedite your call and allow us to provide you with the best consumer service possible. You can reference the parts list located in your manual to identify the specific part numbers.



Email Us

You can email our consumer service department with questions regarding your Minn Kota products. To email your question, visit minnkotamotors.com and click on “Support”.



Authorized Service Centers

Minn Kota has over 800 authorized service providers in the United States and Canada where you can purchase parts or get your products repaired. Please visit our Authorized Service Center page on our website to locate a service provider in your area.



Scan to visit Minn Kota service online.



COMPLIANCE STATEMENTS

ENVIRONMENTAL COMPLIANCE STATEMENT

It is the intention of JOME to be a responsible corporate citizen, operating in compliance with known and applicable environmental regulations, and a good neighbor in the communities where we make or sell our products.

WEEE DIRECTIVE

EU Directive 2002/96/EC “Waste of Electrical and Electronic Equipment Directive (WEEE)” impacts most distributors, sellers, and manufacturers of consumer electronics in the European Union. The WEEE Directive requires the producer of consumer electronics to take responsibility for the management of waste from their products to achieve environmentally responsible disposal during the product life cycle.

WEEE compliance may not be required in your location for electrical & electronic equipment (EEE), nor may it be required for EEE designed and intended as fixed or temporary installation in transportation vehicles such as automobiles, aircraft, and boats. In some European Union member states, these vehicles are considered outside of the scope of the Directive, and EEE for those applications can be considered excluded from the WEEE Directive requirement.

This symbol (WEEE wheelie bin) on product indicates the product must not be disposed of with other household refuse. It must be disposed of and collected for recycling and recovery of waste EEE. Johnson Outdoors Inc. will mark all EEE products in accordance with the WEEE Directive. It is our goal to comply in the collection, treatment, recovery, and environmentally sound disposal of those products; however, these requirements do vary within European Union member states. For more information about where you should dispose of your waste equipment for recycling and recovery and/or your European Union member state requirements, please contact your dealer or distributor from which your product was purchased.



DISPOSAL

Minn Kota motors are not subject to the disposal regulations EAG-VO (electric devices directive) that implements the WEEE directive. Nevertheless never dispose of your Minn Kota motor in a garbage bin but at the proper place of collection of your local town council.

Never dispose of battery in a garbage bin. Comply with the disposal directions of the manufacturer or his representative and dispose of them at the proper place of collection of your local town council.

REGULATORY COMPLIANCE INFORMATION

› i-Pilot Equipped Motors

For regulatory information on motors that come factory installed with i-Pilot, please refer to the i-Pilot Owner's Manual online at minnkotamotors.com.

› i-Pilot Link Equipped Motors

For regulatory information on motors that come factory installed with i-Pilot Link, please refer to the i-Pilot Link Owner's Manual online at minnkotamotors.com.

FCC COMPLIANCE

FCC COMPLIANCE

This device complies with Part 15 of the FCC rules. **Operation is subject to the following two conditions:**

1. This device may not cause harmful interference.
2. This device must accept any interference that may be received, including interference that may cause undesired operation.

Changes or modifications not expressly approved by Johnson Outdoors Marine Electronics, Inc. could void the user's authority to operate this equipment.

NOTICE: This equipment has been tested and found to comply with the limits for a Class B digital device, pursuant to part 15 of the FCC Rules. These limits are designed to provide reasonable protection against harmful interference in a residential installation. This equipment generates, uses and can radiate radio frequency energy and, if not installed and used in accordance with the instructions, may cause harmful interference to radio communications. However, there is no guarantee that interference will not occur in a particular installation. **If this equipment does cause harmful interference to radio or television reception, which can be determined by turning the equipment off and on, the user is encouraged to try to correct the interference by one or more of the following measures:**

- Reorient or relocate the receiving antenna.
- Increase the separation between the equipment and receiver.
- Connect the equipment into an outlet on a circuit different from that to which the receiver is connected.
- Consult the dealer or an experienced radio/TV technician for help.

INDUSTRY CANADA COMPLIANCE

This product meets the applicable Industry Canada technical specifications. Operation is subject to the following two conditions: (1) this device may not cause interference, and (2) this device must accept any interference, including interference that may cause undesired operation of the device.

Changes or modifications not expressly approved by Johnson Outdoors Marine Electronics, Inc. could void the user's authority to operate this equipment.

ENVIRONMENTAL RATINGS

Ambient operating temperature range: -10C to 50C

Ambient operating humidity range: 5% to 95%

Maximum operating altitude: 10,000 feet

ULTERRA COMPLIANCE

› i-Pilot Equipped Motors

- IC: 4397A-ULTERRAIP15
- FCC ID: T62-ULTERRAIP15

› i-Pilot Link Equipped Motors

- IC: 4397A-ULTERRA20
- FCC ID: T62-ULTERRA20

RADIO OPERATION

NON-EUROPEAN

- Frequency band: 915 MHz to 921 MHz
- Maximum RF power transmitted: 0 dBm

EUROPEAN

- Frequency band: 864 MHz to 870 MHz
- Maximum RF power transmitted: 0 dBm

CE MASTER USER MANUAL (FOR CE CERTIFIED MODELS)

PARTS DIAGRAM & PARTS LIST

ULTERRA - 80/112 LBS THRUST - 24/36 VOLT - 45"/60"/72" SHAFT

The parts diagram and parts list provides Minn Kota® WEEE compliance disassembly instructions. For more information about where you should dispose of your waste equipment for recycling and recovery and/or your European Union member state requirements, please contact your dealer or distributor from which your product was purchased. Tools required, but not limited to: flat head screwdriver, Phillips screwdriver, socket set, pliers, wire cutters.

ULTERRA CONTROL HEAD >

> Control Head Parts Diagram

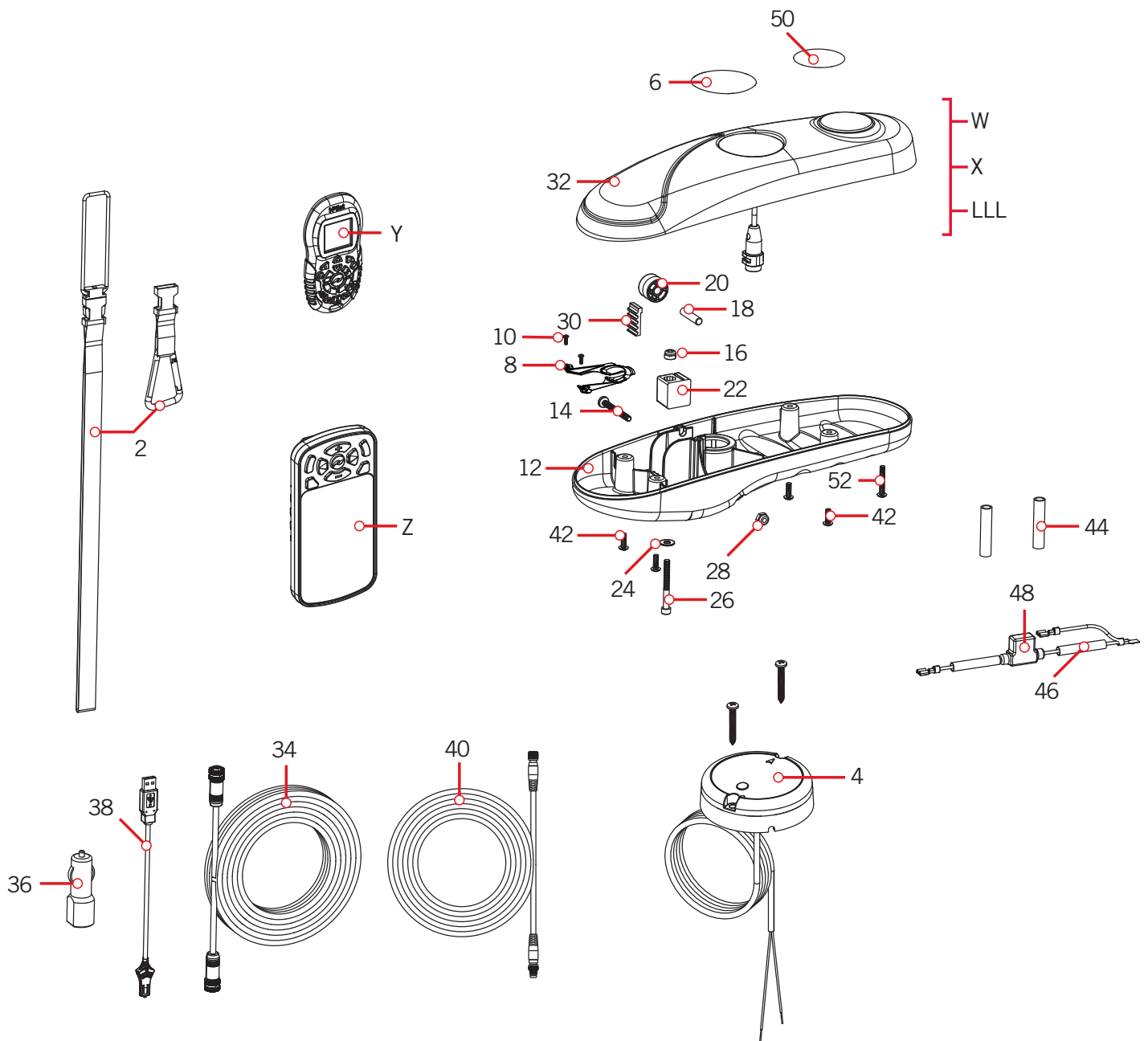

PARTS DIAGRAM & PARTS LIST

Control Head Parts List

Assembly	Part #	Description	Notes	Quantity
W	2774119	MOTOR KIT, iPILOT CONTROLLER 1.6 ULT	◆ *i-PILOT RECEIVER*	1
X	2774117	MOTOR KIT, iPLINK CONTROLLER 3.0 ULT	● *i-PILOT LINK RECEIVER*	1
Y	2994075	REMOTE ASSY, IPILOT 1.6	◆	1
Z	2994076	REMOTE ASSY, IPILOT LINK	●	1
LLL	2774115	iPILOT CONTROLLER 3.0 ULT/MSI	* ●	1
Item	Part #	Description	Notes	Quantity
2	2370817	LANYARD w/CARABINEER, IP REMOTE	◆ ●	1
4	2996400	HEADING SENSOR ASSEMBLY	◆ ●	1
6	2205534	DECAL-GENERIC, PUSH BTN TOP FW		1
	2205530	DECAL, PUSH BTN TOP, ULT 112 FW	*112LB THRUST*	1
	2205532	DECAL, PUSH BTN TOP, ULT 80 FW	*80LB THRUST*	1
8	2224706	PLUG, SCREW-DOWN, BLK		1
10	2372103	SCREW. #6 x 3/8 PLASTITE		2
12	2202506	CONTROL BOX BOTTOM, FW		1
14	2383407	SCREW-#10-24 X 2" PPH ZINC		1
16	2333101	NUT-HEX #10-24 UNC-2B NYL SS		1
18	2202635	PIN-DOWEL, 1/4" OD SS		1
20	2202335	PULLEY, BELT, TOP		1
22	2202800	BLOCK, BELT		1
24	2201721	WASHER-#10 SAE, SS		1
26	2203411	SCREW-#10-24, SHCS, SS, RIE 4606		1
28	2333101	NUT-HEX #10-24 UNC-2B NYL SS		1
30	2200800	BELT-RACK		1
32	2200208	CONTROL BOX COVER, FW		1
34	490389-1	CABLE, ETH (M12-M-M12-F, 30'	● *LINK*	1
36	2395900	ADAPTER, USB POWER PORT, HO, DC	●	1
38	2373241	CABLE, USB REMOTE CHARGER LINK	●	1
40	2211415	CABLE-EXTENSION, PD/AP 110"	+ *US2*	1
	490507-1	CABLE, ADP-INT MDI 14 M12-120"	➔ *MDI*	1
	490516-3	CABLE-INT MSI 14 M12-156" GRND	* *MSI*	1
42	2372100	SCREW-#8-18 X 5/8 THD* (SS		4
44	2065400	WIRE INSULATOR-LGE 1-3/4, BLUE		2
46	2375400	SHRINK TUBE-1/4OD X 1-3/4		2
48	2218201	FUSE HOLDER ASSEMBLY		1
50	2395545	DECAL, DOMED IPILOT FW	◆	1
	2395547	DECAL, DOMED IPILOT LINK FW	●	1

- ▲ Not shown on Parts Diagram.
- ◆ This part is included in an assembly and cannot be ordered individually.
- Only available with models factory installed with i-Pilot.
- Only available with models factory installed with i-Pilot Link.

- + Only available with models factory installed with Universal Sonar.
- ➔ Only available with models factory installed with Built-in MEGA Down Imaging.
- * Only available with models factory installed with Built-in MEGA Side Imaging.

PARTS DIAGRAM & PARTS LIST



Item	Part #	Description	Notes	Quantity
52	2203403	SCREW-#6 X 1.0 BRASS HI-LO		1
▲	2256300	TIE WRAP-5.5" BLACK		2
▲	2297165	MANUAL - DISCLAIMER, DOWNLOAD INFO		1
▲	2207111	MANUAL ULTERRA BT		1
▲	2397100	MANUAL, iPILOT 1.6		1
▲	2397106	GUIDE-QUICK REF, iPILOT 1.6		1
▲	2397102	MANUAL, iPILOT LINK 3.0		1
▲	2397107	GUIDE-QUICK REF, iPILOT 3.0		1
▲	2207113	MANUAL,INSTALL GUIDE, ULT.		1
▲	2394900	INSTRUCTIONS, HEADING SENSOR		1
▲	2207105	QUICK REFERENCE GUIDE - ULTERRA		1
▲	2015800	HANG TAG. "CAUTION...TILT HINGE"		1

- ▲ Not shown on Parts Diagram.
- ✘ This part is included in an assembly and cannot be ordered individually.
- ◆ Only available with models factory installed with i-Pilot.
- Only available with models factory installed with i-Pilot Link.

- ⊕ Only available with models factory installed with Universal Sonar.
- ➔ Only available with models factory installed with Built-in MEGA Down Imaging.
- * Only available with models factory installed with Built-in MEGA Side Imaging.



PARTS DIAGRAM & PARTS LIST

ULTERRA 24 VOLT 4" MOTOR >

> 24 Volt 4" Motor Parts Diagram

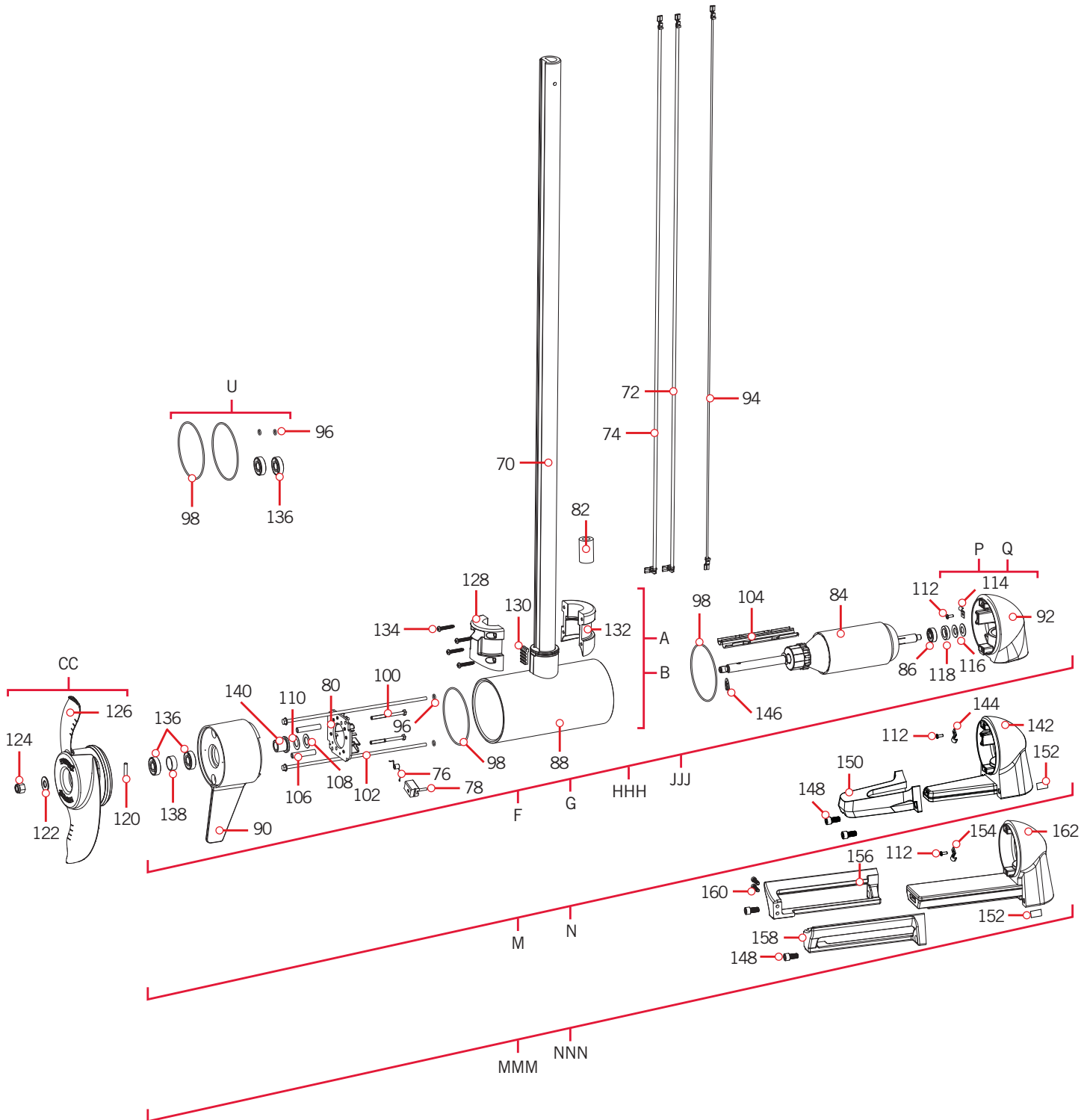

PARTS DIAGRAM & PARTS LIST

24 Volt 4" Motor Parts List

Assembly	Part #	Description	Notes	Quantity
A	2777098	CTR HSG ASY, CB, 80#, FW, 45" TUBE	*TUBE* *NOT FOR MDI MODELS*	1
B	2777099	CTR HSG ASY, CB, 80#, FW, 60" TUBE	*TUBE* *NOT FOR MDI MODELS*	1
F	2777016	MTR/TUBE ASSY 80# 45" US2	+ *MOTOR & TUBE*	1
G	2777015	MTR/TUBE ASSY 80# 60" US2	+ *MOTOR & TUBE*	1
CC	1378132	80# THRUST PROP KIT		1
P	9421-287	PLN END HSG/TRANSDUCER ASY 4.0	+ *80LB THRUST* *45*	1
Q	9421-290	PLN END HSG/TRANSDUCER ASY 4.0	+ *80LB THRUST* *60*	1
U	2889460	SEAL & O-RING KIT	*80LB THRUST*	1
M	2777136	MTR/TUBE ASM 80# 60" ULT/MDI BT	➔ *MOTOR & TUBE*	1
N	2777137	MTR/TUBE ASM 80# 45" ULT/MDI BT	➔ *MOTOR & TUBE*	1
HHH	2777008	MTR/TUBE 80# 45" ULT/US2-M	+ *MOTOR & TUBE* *M SKU* *A SKU*	1
JJJ	2777009	MTR/TUBE 80# 60" ULT/US2-M	+ *MOTOR & TUBE* *M SKU* *A SKU*	1
MMM	2777141	MTR/TUBE 80# 45" ULT/MSI BT	* *MOTOR & TUBE*	1
NNN	2777142	MTR/TUBE 80# 60" ULT/MSI BT	* *MOTOR & TUBE*	1
Item	Part #	Description	Notes	Quantity
70	✘	TUBE-COMP, BLK, 60", w/1/4" WALL n	*SEE B, JJJ OR G*	1
	✘	TUBE-CMP, BLK, 60", 1/4" WALL	*60in* *A SKU* *SEE G, JJJ OR M*	1
	✘	TUBE-COMP, BLK, 45", w/1/4" WALL	*SEE A, F, HHH OR N*	1
	✘	TUBE-CMP, BLK, 45", 1/4" WALL	*SEE A, F, HHH OR N*	1
	✘	TUBE-CMP, BLK, 45", 1/4", DI BORED	*SEE N*	1
	✘	TUBE-CMP, BLK, 60", 1/4", DI BORED	*SEE M*	1
▲	✘	SEAL, BUNG UPPER, FW		1
▲	✘	SEAL, BUNG LOWER		1
72	640-022	LEADWIRE BLK 10 AWG 72.5 XLP	*4* *80LB THRUST* *60*	1
	640-016	LEADWIRE BLK 10AWG 56 1/2 XLP	*4* *80LB THRUST* *45*	1
74	640-126	LEADWIRE RED 10AWG 71" XLP	*4* *80LB THRUST* *60*	1
	640-118	LEADWIRE RED 10 AWG 56 XLP	*4* *80LB THRUST* *45*	1
▲	✘	BRUSH HOLDER	*4* *80LB THRUST*	2
76	975-041	SPRING - TORSION	*4* *80LB THRUST*	2
78	188-094	BRUSH W/TERMINAL	*4* *80LB THRUST*	2
80	9-738-015	BRUSH PLATE-4" terminal	*4* *80LB THRUST*	1
82	✘	BEAD-FERRITE	*A SKU* *M SKU*	1
▲	✘	RIVET-.25"	*4* *80LB THRUST*	6
▲	2260730	CONNECTOR 1/4 MALE TAB QD	*4* *80LB THRUST*	2
84	2-100-214	ARM ASSY 24V 4" 80# (WW2)	*4* *80LB THRUST*	1

- ▲ Not shown on Parts Diagram.
- ✘ This part is included in an assembly and cannot be ordered individually.
- ◆ Only available with models factory installed with i-Pilot.
- Only available with models factory installed with i-Pilot Link.

- + Only available with models factory installed with Universal Sonar.
- ➔ Only available with models factory installed with Built-in MEGA Down Imaging.
- * Only available with models factory installed with Built-in MEGA Side Imaging.

PARTS DIAGRAM & PARTS LIST



Item	Part #	Description	Notes	Quantity
86	140-010	BEARING - BALL	*4* *80LB THRUST*	1
88	✘	CTR HSG ASY 4.0 FW -MGNTZ	*4* *80LB THRUST* *ASSEMBLY A OR B*	1
90	2-300-170	BRUSH END HSG ASY 4.0 FW	*4* *80LB THRUST*	1
92	✘	PLAIN END HSG-PNTD-4"US2.5 CB	✚ *4* *80LB THRUST* *ASSEMBLY P OR Q*	1
94	640-316	BONDING WIRE BROWN 18 AWG 71" GPT	*4* *80LB THRUST* *60*	1
	640-315	BONDING WIRE BROWN 18 AWG 62" GPT	*4* *80LB THRUST* *45*	1
96	701-009	O-RING	*THRU BOLT*	2
98	701-043	O-RING	*4* *80LB THRUST*	2
100	830-027	SCREW - SELF-THREAD 10-32X2.25	*4* *80LB THRUST*	2
102	830-095	THRU BOLT 12-24 x 9.79	*4* *80LB THRUST*	2
104	582-013	CLIP, RETAINING SHORT	*4* *80LB THRUST*	1
106	973-025	SPACER - BRUSHPLATE	*4* *80LB THRUST*	2
108	990-051	WASHER - STEEL THRUST		1
110	990-052	WASHER - NYLATRON		1
112	2302104	SCREW-#6-20 X 3/8 THD CUTS,RIE		1
114	230-038	CABLE CLAMP	✚ *US2*	1
116	992-010	WASHER - BELLEVILLE		2
118	990-045	SPACER - THRUST		1
120	2262658	PIN-DRIVE 1" X 3/16" S/S		1
122	2091701	WASHER-PROP (LARGE) MAX101		1
124	2093101	NUT-PROP,NYLOC,LG,MX101 3/8 SS		1
126	2331160	PROP-WW2 (4") w/ADP.RING		1
128	2201505	COLLAR, BELT CLAMP		1
130	2200800	BELT-RACK, LOWER		1
132	2201500	COLLAR, CLAMP		1
134	3393480	SCREW-#10 X 1.0" PPH HI-LO SS		4
136	888-025	SEAL		2
138	725-095	PAPER TUBE		1
140	144-017	BEARING		1
142	✘	PLAIN END HOUSING PAINTED 4.0 DI	➔	1
144	230-039	CABLE CLAMP	➔ *MDI*	1
146	788-040	RETAINING RING		1
148	830-110	SCREW 5-16 - 18 X 5/8 SHCS SS	➔ *	2
150	792-001	GUARD TRANSDUCER, PNT 4.0 DI	➔	1
152	2006621	DECAL-LOWER UNIT, MDI	➔ *	1
154	230-040	CABLE CLAMP, 1/4" STEEL	*	1
156	792-015	GUARD, TRANSDUCER PNT 4.5 SI RIGHT	*	1

- ▲ Not shown on Parts Diagram.
- ✘ This part is included in an assembly and cannot be ordered individually.
- ◆ Only available with models factory installed with i-Pilot.
- Only available with models factory installed with i-Pilot Link.

- ✚ Only available with models factory installed with Universal Sonar.
- ➔ Only available with models factory installed with Built-in MEGA Down Imaging.
- * Only available with models factory installed with Built-in MEGA Side Imaging.



PARTS DIAGRAM & PARTS LIST



Item	Part #	Description	Notes	Quantity
158	792-016	GUARD, TRANSDUCER, PNT 4.5 SI LEFT	*	1
160	2063410	SCREW-#10-32 X 3/4" CAP SS	*	2
162	✘	PLN END HSG/TRNDCR 4.0 MSI ASM	*	1

- ▲ Not shown on Parts Diagram.
- ✘ This part is included in an assembly and cannot be ordered individually.
- ◆ Only available with models factory installed with i-Pilot.
- Only available with models factory installed with i-Pilot Link.

- ⊕ Only available with models factory installed with Universal Sonar.
- ➔ Only available with models factory installed with Built-in MEGA Down Imaging.
- * Only available with models factory installed with Built-in MEGA Side Imaging.

PARTS DIAGRAM & PARTS LIST

ULTERRA 36 VOLT 4.5" MOTOR

36 Volt 4.5" Motor Parts Diagram

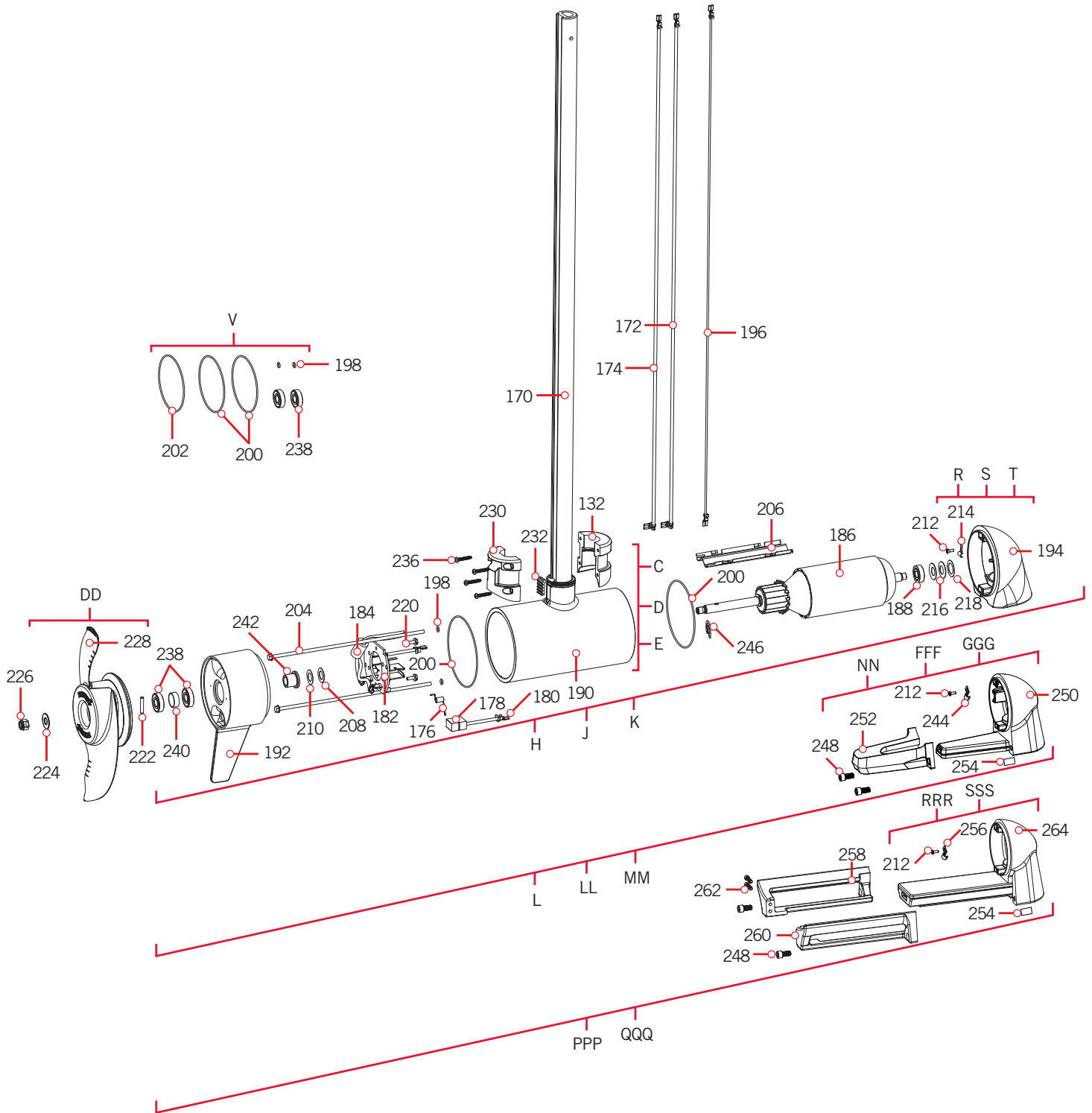

PARTS DIAGRAM & PARTS LIST

36 Volt 4.5" Motor Parts List

Assembly	Part #	Description	Notes	Quantity
C	2777248	CTR HSG ASY, CB, 112#, FW, 45" TUBE	*TUBE*	1
D	2777249	CTR HSG ASY, CB, 112#, FW, 60" TUBE	*TUBE*	1
E	2777250	CTR HSG ASY, CB, 112#, FW, 72" TUBE	*TUBE*	1
H	2777086	MTR/TUBE ASSY 112# 45" US2	+ *MOTOR & TUBE*	1
J	2777085	MTR/TUBE ASSY 112# 60" US2	+ *MOTOR & TUBE*	1
K	2777087	MTR/TUBE ASSY 112# 72" US2	+ *MOTOR & TUBE*	1
DD	1378160	112# THRUST PROP KIT		1
R	9421-244	PLN END HSG/TRANSDUCER ASY 4.5	+ *112LB THRUST* *45*	1
S	9421-246	PLN END HSG/TRANSDUCER ASY 4.5	+ *112LB THRUST* *60*	1
T	9421-247	PLN END HSG/TRANSDUCER ASY 4.5	+ *112LB THRUST* *72*	1
V	2881450	SEAL & O-RING KIT 112	*112LB THRUST*	1
L	2777157	MTR/TUBE ASM 112#45"ULT/MDI BT	➔ *MOTOR & TUBE*	1
LL	2777155	MTR/TUBE ASM 112#72"ULT/MDI BT	➔ *MOTOR & TUBE*	1
MM	2777156	MTR/TUBE ASM 112#60"ULT/MDI BT	➔ *MOTOR & TUBE*	1
NN	2773002	PLN END HSG/TRNDPCR 4.5 MDI	➔ *112LB THRUST* *45"*	1
FFF	2773005	PLN END HSG/TRNDPCR 4.5 MDI	➔ *112LB THRUST* *72"*	1
GGG	2773006	PLN END HSG/TRNDPCR 4.5 MDI	➔ *112LB THRUST* *60"*	1
PPP	2777158	MTR/TUBE ASM 112# 60" ULT/MSI BT	* *MOTOR & TUBE*	1
QQQ	2777159	MTR/TUBE ASM 112# 72" ULT/MSI BT	* *MOTOR & TUBE*	1
RRR	2993016	PLN END HSG/TRNDUCER 4.5 MSI ASM	* *60"*	1
SSS	2993017	PLN END HSG/TRNDUCER 4.5 MSI ASM	* *72"*	1
Item	Part #	Description	Notes	Quantity
170	✘	TUBE-COMP,BLK,60", w/1/4" WALL	*SEE D, J OR MM*	1
	✘	TUBE-COMP,BLK,45", w/1/4" WALL	*SEE C, H OR L*	1
	✘	TUBE-COMP,BLK,72",w/1/4" WALL	*SEE E, LL OR K*	1
▲	✘	SEAL,BUNG UPPER,FW		1
▲	✘	SEAL,BUNG LOWER		1
172	640-045	LEADWIRE BLK 10AWG 76 1/2" GPT	*4.5* *112LB THRUST* *60*	1
	640-049	LEADWIRE BLK 10AWG 88.50" GPT	*4.5* *112LB THRUST* *72*	1
	640-040	LEADWIRE BLK 10AWG 62 1/4" GPT	*4.5* *112LB THRUST* *45*	1
174	640-145	LEADWIRE RED 10AWG 75 7/8" GPT	*4.5* *112LB THRUST* *60*	1
	640-149	LEADWIRE RED 10AWG 88" GPT	*4.5* *112LB THRUST* *72*	1
	640-140	LEADWIRE RED 10AWG 61 1/2" GPT	*4.5* *112LB THRUST* *45*	1
▲	✘	BRUSH HOLDER	*4.5* *112LB THRUST*	2
176	975-045	SPRING-TORSION	*4.5* *112LB THRUST*	2
178	188-095	BRUSH	*4.5* *112LB THRUST*	2

- ▲ Not shown on Parts Diagram.
- ✘ This part is included in an assembly and cannot be ordered individually.
- ◆ Only available with models factory installed with i-Pilot.
- Only available with models factory installed with i-Pilot Link.

- + Only available with models factory installed with Universal Sonar.
- ➔ Only available with models factory installed with Built-in MEGA Down Imaging.
- * Only available with models factory installed with Built-in MEGA Side Imaging.

PARTS DIAGRAM & PARTS LIST



Item	Part #	Description	Notes	Quantity
180	2260731	TERMINAL 1/4" MALE TAB-THREE	*4.5* *112LB THRUST*	2
182	738-011	BRUSH PLATE	*4.5* *112LB THRUST*	1
184	2307312	BEAD-FERRITE	*A SKU* *M SKU* *4.5* *112LB THRUST*	1
186	2-100-245	ARMATURE ASY 4.5"LWR UNIT	*4.5* *112LB THRUST*	1
188	140-014	BEARING-BALL 6000	*4.5* *112LB THRUST*	1
190	✘	CTR HSG ASY 4.5" MAG FW CB TER	*4.5* *112LB THRUST* *ASSEMBLY C, D OR E*	1
192	2-300-155	BRUSH END HSG ASY 4.5" FW	*4.5* *112LB THRUST*	1
194	✘	PLN END HSG 4.5" US2.5 PNT FW	✚ *4.5* *112LB THRUST* *ASSEMBLY R, S OR T*	1
196	640-317	BONDING WIRE BROWN 18 AWG 86" GPT	*4.5* *112LB THRUST* *72*	1
	640-315	BONDING WIRE BROWN 18 AWG 62" GPT	*4.5* *112LB THRUST* *45*	1
198	701-009	O-RING	*THRU BOLT*	2
200	701-098	O-RING, 98MM X 2MM	*4.5* *112LB THRUST*	2
202	701-103	O-RING,103MM X 3.00MM, 70 BUNA	*4.5* *112LB THRUST*	1
204	830-094	THRU BOLT 12-24 X10.31	*4.5* *112LB THRUST*	2
206	582-016	CLIP-RETAINING, SONAR	*4.5* *112LB THRUST*	1
208	990-051	WASHER - STEEL THRUST		1
210	990-052	WASHER - NYLATRON		1
212	2302104	SCREW-#6-20 X 3/8 THD CUTS,RIE		1
214	230-038	CABLE CLAMP	✚ *US2*	1
216	992-011	WASHER-BELLEVILLE	*4.5* *112LB THRUST*	2
218	990-011	WASHER-SHIM OD 1",ID.630"SS	*4.5* *112LB THRUST*	1
220	2053410	SCREW-#8-32 X 1/2 TRI-LOBE HEX	*4.5* *112LB THRUST*	2
222	2262658	PIN-DRIVE 1" X 3/16" S/S		1
224	2091701	WASHER-PROP (LARGE) MAX101		1
226	2093101	NUT-PROP,NYLOC,LG,MX101 3/8 SS		1
228	2341160	PROP-WW2 (4.5) w/ADP.RING		1
230	2201505	COLLAR, BELT CLAMP		1
232	2200800	BELT-RACK, LOWER		1
234	2201500	COLLAR, CLAMP		1
236	3393480	SCREW-#10 X 1.0" PPH HI-LO SS		4
238	888-025	SEAL		2
240	725-095	PAPER TUBE		1
242	144-017	BEARING		1
244	230-039	CABLE CLAMP	➔ *MDI*	1
246	788-040	RETAINING RING		1
248	830-110	SCREW 5-16 - 18 X 5/8 SHCS SS	➔ *	2
250	✘	PLAIN END HOUSING, PNT 4.5 DI	➔ *SEE NN, FFF OR GGG*	1

- ▲ Not shown on Parts Diagram.
- ✘ This part is included in an assembly and cannot be ordered individually.
- ◆ Only available with models factory installed with i-Pilot.
- Only available with models factory installed with i-Pilot Link.

- ✚ Only available with models factory installed with Universal Sonar.
- ➔ Only available with models factory installed with Built-in MEGA Down Imaging.
- * Only available with models factory installed with Built-in MEGA Side Imaging.



PARTS DIAGRAM & PARTS LIST



Item	Part #	Description	Notes	Quantity
252	792-005	GUARD TRANSDUCER, PNT 4.5 DI	➔	1
254	2006621	DECAL-LOWER UNIT, MDI	➔ *	1
256	230-040	CABLE CLAMP, 1/4" STEEL	* *US2*	1
258	792-015	GUARD, TRANSDUCER PNT 4.5 SI RIGHT	*	1
260	792-016	GUARD, TRANSDUCER, PNT 4.5 SI LEFT	*	1
262	2063410	SCREW-#10-32 X 3/4" CAP SS	*	2
264	✘	PLN END HSG/TRNDCR 4.0 MSI ASM	*	1

- ▲ Not shown on Parts Diagram.
- ✘ This part is included in an assembly and cannot be ordered individually.
- ◆ Only available with models factory installed with i-Pilot.
- Only available with models factory installed with i-Pilot Link.

- ⊕ Only available with models factory installed with Universal Sonar.
- ➔ Only available with models factory installed with Built-in MEGA Down Imaging.
- * Only available with models factory installed with Built-in MEGA Side Imaging.



PARTS DIAGRAM & PARTS LIST

ULTERRA STEERING HOUSING

Steering Housing Parts Diagram

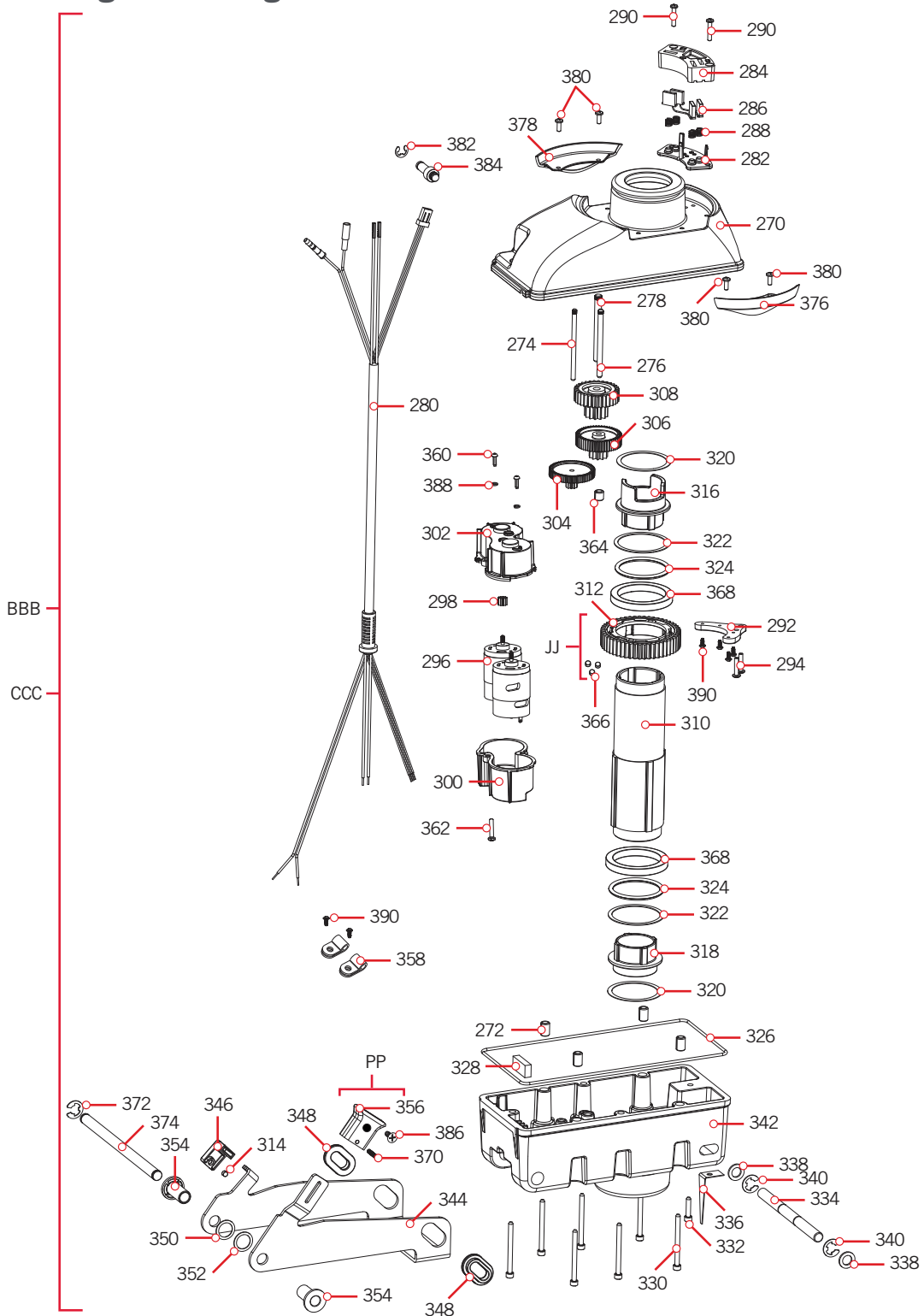

PARTS DIAGRAM & PARTS LIST

Steering Housing Parts List

Assembly	Part #	Description	Notes	Quantity
BBB	2996521	ASM, STEERING 24V	*80LB THRUST*	1
CCC	2996522	ASM, STEERING 36V	*112 LB THRUST*	1
JJ	2772200	OUTPUT GEAR W/MAGNETS		1
PP	2770100	RELEASE KNOB WITH SCREW KIT		1
Item	Part #	Description	Notes	Quantity
270	✘	STEERING HSG COVER FW BLK	*SEE BBB OR CCC*	1
272	✘	PIN-ROLL 5/16" X 1/2"	*SEE BBB OR CCC*	4
274	✘	SHAFT-GEAR, FIRST CLUSTER	*SEE BBB OR CCC*	1
276	✘	SHAFT-GEAR,INTERMED.CLUSTER	*SEE BBB OR CCC*	1
278	✘	SHAFT-GEAR, THIRD CLUSTER	*SEE BBB OR CCC*	1
280	✘	LEADWIRE,STEERING MTR, 8 COND.	*SEE BBB OR CCC*	1
282	✘	INSULATOR, BLOCK-BRUSH	*SEE BBB OR CCC*	1
284	✘	BLOCK-BRUSH, SLIPRING	*SEE BBB OR CCC*	1
286	✘	BRUSH SHUNT ASSEMBLY	*SEE BBB OR CCC*	2
288	✘	BUMPER BRUSH BLOCK	*SEE BBB OR CCC*	4
290	2203408	SCREW-#6-32 X .75" PPH, NYLON		2
292	2201920	BRACKET-SENSOR, STEERING HSG		1
294	2303412	SCREW-#6-20 X 5/8 SELF TAP		2
296	✘	MOTOR, STEERING 36V FW T2	*112LB THRUST* *SEE CCC*	1
	✘	MOTOR, STEERING 24V T2	*80LB THRUST* *SEE BBB*	1
298	2322215	GEAR-PINION, DR.HSG, STAGE 1		1
300	2322520	CASE-MOTOR,STRG HSG,TOP		1
302	2322525	CASE-MOTOR,STRG HSG,BTM		1
304	2322210	GEAR & PINION, DR.HSG, STAGE 2		1
306	2302250	GEAR & PINION,DR. HSG, STAGE 3		1
308	2302255	GEAR & PINION,DR. HSG, STAGE 4		1
310	2322030	TUBE-OUTPUT, MACHINED		1
312	2322200	GEAR-OUTPUT		1
314	✘	MAGNET-.187X.125 NCKL PLT(N/A)	*SEE 346*	1
316	2201510	COLLAR-DRIVE, OUTPUT TUBE		1
318	2321510	COLLAR-DRIVE,BOTTOM		1
320	2321704	WASHER-THRUST, STEERING		2
322	2321720	SHIM,O-RING		2
324	2324608	O-RING,224,STR HSG		2
326	2324604	O-RING, CASE SEAL		1
328	2308601	BREATHER FILTER, DR.HOUSING		1

- ▲ Not shown on Parts Diagram.
- ✘ This part is included in an assembly and cannot be ordered individually.
- ◆ Only available with models factory installed with i-Pilot.
- Only available with models factory installed with i-Pilot Link.

- +
 - ➔
 - *
- Only available with models factory installed with Universal Sonar.
 Only available with models factory installed with Built-in MEGA Down Imaging.
 Only available with models factory installed with Built-in MEGA Side Imaging.

PARTS DIAGRAM & PARTS LIST



Item	Part #	Description	Notes	Quantity
330	2323408	SCREW-#8-32 X 2.0 SHCS SS		7
332	2323410	SCREW-#8-32 X .75 SHCS SS		1
334	2202626	PIN-LATCH, SS		1
336	2322702	SPRING, LATCH PIN SS		2
338	2321702	WASHER-FLAT .375 NYLON		2
340	2263011	E-RING 3/8 DIA. SHAFT*		2
342	✘	HOUSING-STEERING, BTM, FW	*SEE BBB OR CCC*	1
344	2201910	BRACKET, TILT, ZP		1
346	2208600	HOLDER-MAGNET w/MAGNET		1
348	2207305	BUSHING, LATCH PIN		2
350	2201730	WASHER-FLAT, .56 ID NYLON	*BLACK*	1
352	2201731	WASHER-FLAT, NYLON	*WHITE*	1
354	2207310	BUSHING,STEERING HSG, PIVOT		2
356	2200100	KNOB, TILT RELEASE		1
358	2052510	CABLE CLAMP, 3/16", NYLON		2
360	2053422	SCREW-M3-.5 X 10 PPH, ZPS		2
362	2043412	SCREW-#8-18 X 3/4 TY AB SS PPH		1
364	2321730	SPACER,GEAR CLUSTER,STEER HSG		1
▲	✘	HOUSING, CONNECTOR WPJ		1
366	✘	MAGNET-.187X.125 NCKL PLT(N/A)	*SEE JJ*	3
368	2327308	BEARING-BALL,SEALED,6809-2RS		2
370	2383463	SCREW-#6-32 X .625"SET SS		1
372	2263011	E-RING 3/8 DIA. SHAFT*		1
374	2202601	PIN-PIVOT, DRIVEHOUSING, ZP		1
376	2205905	ADAPTER, STEERING HSG RIGHT		1
378	2205900	ADAPTER, STEERING HSG LEFT		1
380	2332103	SCREW-#6-20 X 3/8 THD*(SS)		4
382	2263006	E-RING, 5/16, S/S GAS ASSIST		1
384	2202902	STANDOFF, OIL DAMPENER		1
386	2203407	SCREW-#6-32 X .625" PFH, SS		1
388	2051710	SPLIT LOCK WASHER 3MM		4
390	2373440	SCREW-#4-24 X 1/4 PHCR SS		6

- ▲ Not shown on Parts Diagram.
- ✘ This part is included in an assembly and cannot be ordered individually.
- ◆ Only available with models factory installed with i-Pilot.
- Only available with models factory installed with i-Pilot Link.

- ⊕ Only available with models factory installed with Universal Sonar.
- ➔ Only available with models factory installed with Built-in MEGA Down Imaging.
- * Only available with models factory installed with Built-in MEGA Side Imaging.



ULTERRA TRIM HOUSING >

> Trim Housing Parts Diagram

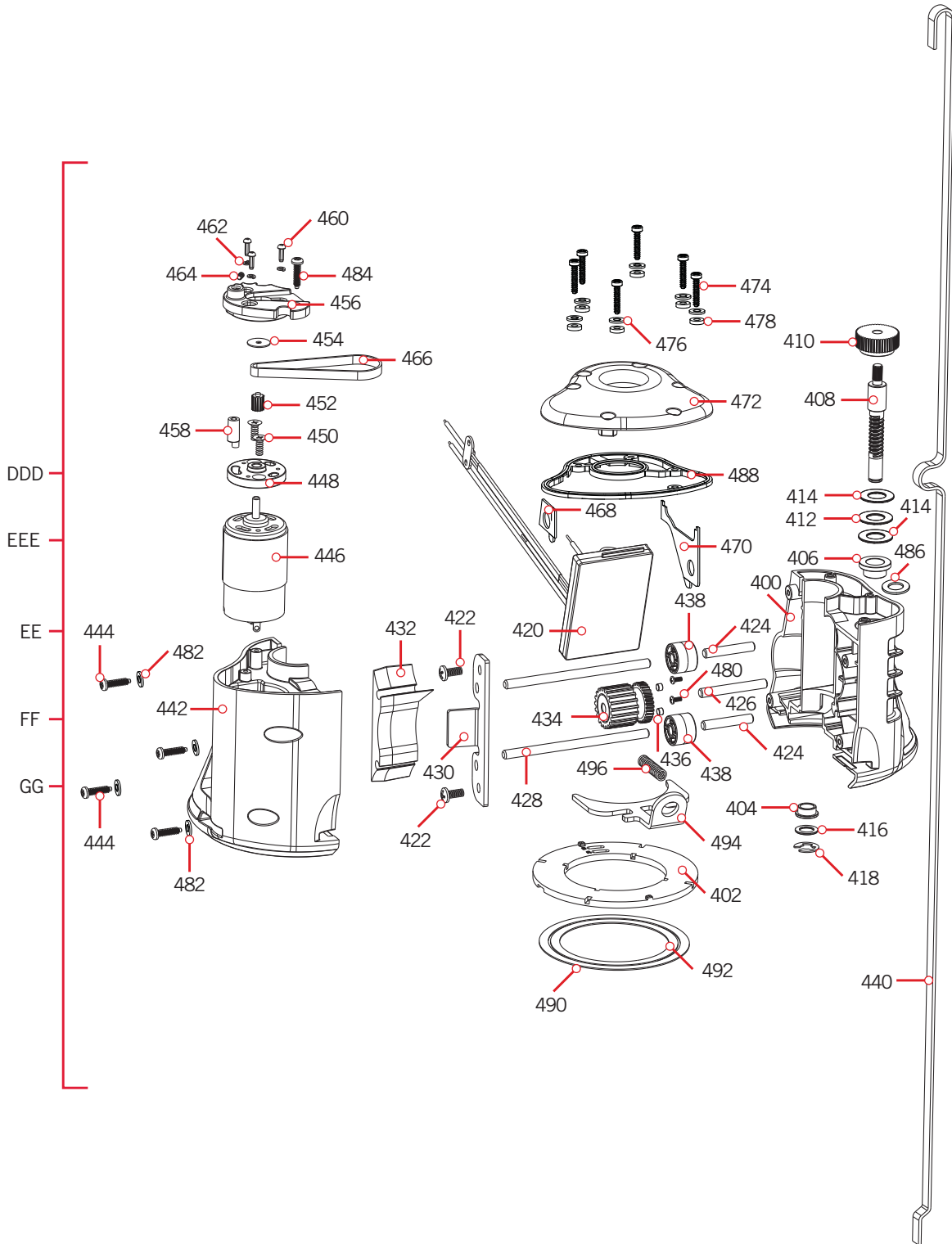

PARTS DIAGRAM & PARTS LIST

Trim Housing Parts List

Assembly	Part #	Description	Notes	Quantity
DDD	2887802	ASSY,TRIM MODULE, FW, 60"		1
EEE	2887820	ASSY,TRIM MODULE, FW, 72"		1
EE	2887807	ASSY,TRIM MODULE, FW, 45"		1
FF	2887827	ASSY,TRIM MOD "M",FW, 45"	*M SKU*	1
GG	2887823	ASSY,TRIM MOD "M",FW, 60"	*M SKU*	1
Item	Part #	Description	Notes	Quantity
400	✘	HOUSING-TRIM, GEAR SIDE	*SEE DDD, EEE, EE, FF OR GG*	1
402	✘	CARRIER, SLIPRING CONTACTS	*SEE DDD, EEE, EE, FF OR GG*	1
404	✘	BUSHING, TRIM, BOTTOM	*SEE DDD, EEE, EE, FF OR GG*	1
406	✘	BUSHING-HAT 1/2"SHFT BRNZ	*SEE DDD, EEE, EE, FF OR GG*	1
408	✘	SHAFT-WORM	*SEE DDD, EEE, EE, FF OR GG*	1
410	✘	PULLEY, TRIM JACKSHAFT, MACH.	*SEE DDD, EEE, EE, FF OR GG*	1
412	✘	BEARING-THRUST, NEEDLE	*SEE DDD, EEE, EE, FF OR GG*	1
414	✘	WASHER-THRUST, 1/2"	*SEE DDD, EEE, EE, FF OR GG*	2
416	✘	WASHER-THRUST, 3/8"	*SEE DDD, EEE, EE, FF OR GG*	1
418	✘	E-RING 3/8 DIA. SHAFT*	*SEE DDD, EEE, EE, FF OR GG*	1
420	✘	BOARD ASSY, WIRELESS TRIM	*SEE DDD, EEE, EE, FF OR GG*	1
	✘	BOARD ASSY, WIRELESS TRIM "M"	*SEE DDD, EEE, EE, FF OR GG*	1
422	✘	SCREW-#4-24 X 1/4 PHCR SS TY B	*SEE DDD, EEE, EE, FF OR GG*	2
424	✘	PIN, BELT PULLEY	*SEE DDD, EEE, EE, FF OR GG*	2
426	✘	PIN, 2' X 1/4"	*SEE DDD, EEE, EE, FF OR GG*	1
428	✘	PIN-DOWEL, 1/8"	*SEE DDD, EEE, EE, FF OR GG*	2
430	✘	BRACKET, DRIVE BLOCK	*SEE DDD, EEE, EE, FF OR GG*	1
432	✘	BLOCK, TUBE DRIVE	*SEE DDD, EEE, EE, FF OR GG*	1
434	✘	GEAR/PULLEY-WORM, CLUSTER ASM	*SEE DDD, EEE, EE, FF OR GG*	1
▲	✘	MAGNET-.187X.125 NCKL PLT(N/A)	*SEE 434*	2
438	✘	PULLEY, BELT, TOP	*SEE DDD, EEE, EE, FF OR GG*	2
440	2770816	BELT-LIFT 45"		1
	2770818	BELT-LIFT 60"		1
	2770819	BELT-LIFT 72"		1
442	✘	HOUSING-TRIM, MOTOR SIDE	*SEE DDD, EEE, EE, FF OR GG*	1
444	✘	SCREW -4MM DELTA PT SS	*SEE DDD, EEE, EE, FF OR GG*	4
446	✘	MOTOR, TRIM	*SEE DDD, EEE, EE, FF OR GG*	1
448	✘	PLATE-ADAPTER, LIFT MOTOR	*SEE DDD, EEE, EE, FF OR GG*	1
450	✘	SCREW-M4 X 10 PFH, ZP	*SEE DDD, EEE, EE, FF OR GG*	2
452	✘	PULLEY, LIFT MOTOR, MACHINED	*SEE DDD, EEE, EE, FF OR GG*	1

- ▲ Not shown on Parts Diagram.
- ✘ This part is included in an assembly and cannot be ordered individually.
- ◆ Only available with models factory installed with i-Pilot.
- Only available with models factory installed with i-Pilot Link.

- ⊕ Only available with models factory installed with Universal Sonar.
- ➔ Only available with models factory installed with Built-in MEGA Down Imaging.
- * Only available with models factory installed with Built-in MEGA Side Imaging.

PARTS DIAGRAM & PARTS LIST



Item	Part #	Description	Notes	Quantity
454	✘	WASHER-#6, .625 OD, ZP STEEL	*SEE DDD, EEE, EE, FF OR GG*	1
456	✘	PLATE-MOTOR	*SEE DDD, EEE, EE, FF OR GG*	1
458	2058411	TENSIONER-BELT		1
460	2053422	SCREW-M3-.5 X 10 PPH, ZPS		3
462	2051710	LOCKWASHER-SPLIT, 3MM, ZP		3
464	2053420	SCREW-SET-#8-32 X 1/4" S/S		1
466	2200810	BELT-TRIM		1
468	2206914	GASKET, TRIM HSG ASM, LFT, BLK		1
470	2206915	GASKET, TRIM HSG ASM, RIGHT BLK		1
472	2206410	COVER, TRIM HOUSING		1
474	2203401	SCREW -4MM DELTA PT SS		6
476	3391732	WASHER, SEALING		6
478	3394602	WASHER-FLAT #8 SS		6
480	2373440	SCREW-#4-24 X 1/4 PHCR SS		2
482	3394602	#8 FLAT WASHER SS		4
484	2203401	SCREW-4MM DELTA PT SS		1
486	✘	O-RING, 014-BUNA N, ULTERRA		1
488	2206911	GASKET, TRIM HOUSING ASSEMBLY BLK		1
490	✘	RING-CONTACT, SLIPRING LARGE	*SEE DDD, EEE, EE, FF OR GG*	1
492	✘	RING-CONTACT, SLIPRING SMALL	*SEE DDD, EEE, EE, FF OR GG*	1
494	✘	HANDLE, TRIM HSG RELEASE, ZP	*SEE DDD, EEE, EE, FF OR GG*	1
496	✘	SPRING-5/16" OD, SS	*SEE DDD, EEE, EE, FF OR GG*	1

- ▲ Not shown on Parts Diagram.
- ✘ This part is included in an assembly and cannot be ordered individually.
- ◆ Only available with models factory installed with i-Pilot.
- Only available with models factory installed with i-Pilot Link.

- ⊕ Only available with models factory installed with Universal Sonar.
- ➔ Only available with models factory installed with Built-in MEGA Down Imaging.
- * Only available with models factory installed with Built-in MEGA Side Imaging.



PARTS DIAGRAM & PARTS LIST

ULTRERRA FOOT PEDAL

Foot Pedal Parts Diagram

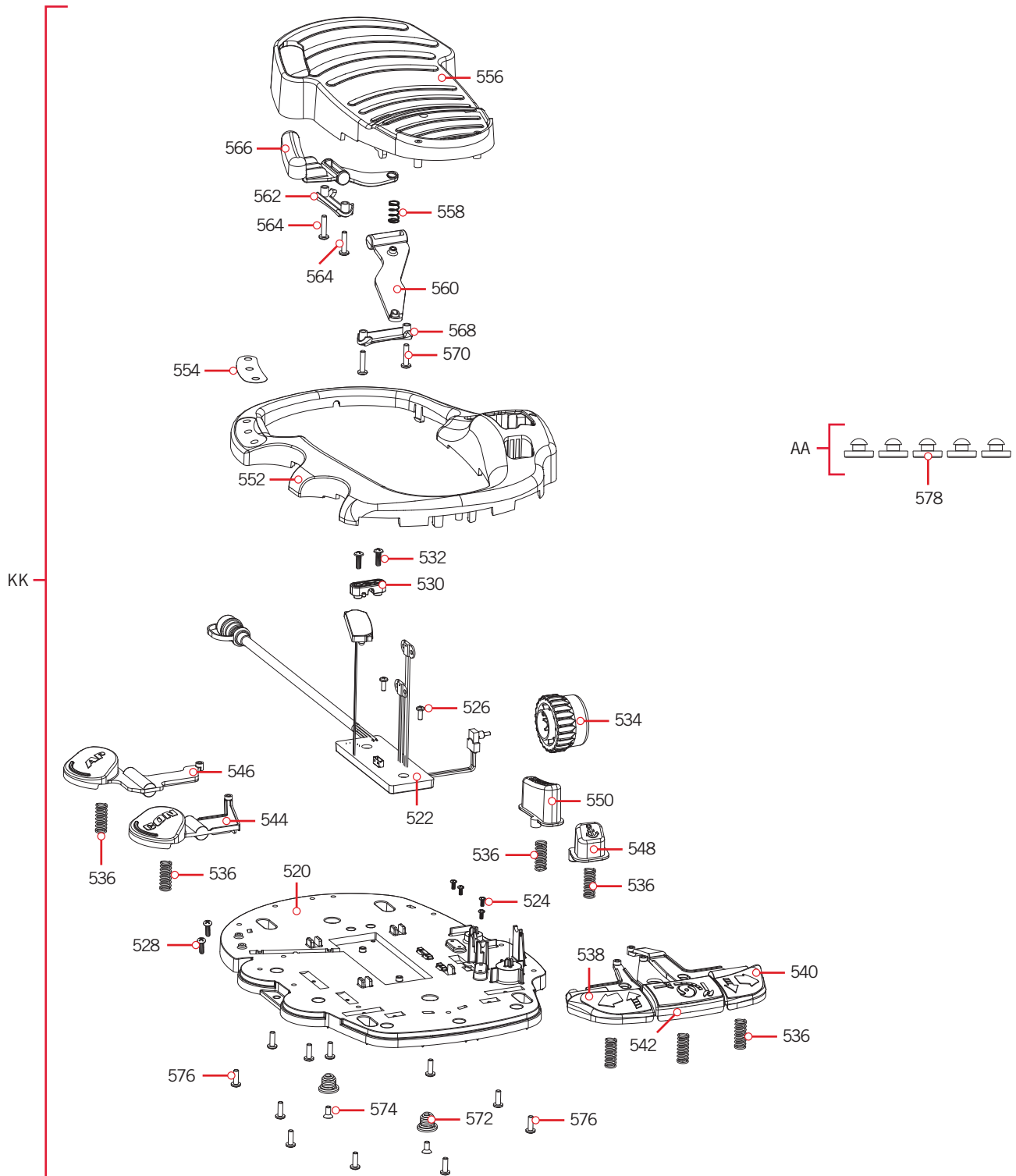

PARTS DIAGRAM & PARTS LIST

Foot Pedal Parts List

Assembly	Part #	Description	Notes	Quantity
KK	2994741	FOOT PEDAL ASSY, ULTERRA		1
AA	2994859	BAG ASY-TERROVA/V2,RUB.BUMPERS		1
Item	Part #	Description	Notes	Quantity
520	2204500	BASE PLATE-ULTERRA / TERROVA		1
522	✘	PCB ASSY, ULTERRA	*SEE KK*	1
524	2373440	SCREW-#4-24 X 1/4 PHCR SS TY B		6
526	2332103	SCREW-#6-20 X 3/8 THD*(SS)		2
528	2302100	SCREW-#6-20 X 1/2 THD CUTS		2
530	2322900	STRAIN RELIEF, FOOT PEDAL		1
532	2372100	SCREW-#8-18 X 5/8 THD* (SS)		2
534	2320100	KNOB-SPEED, FOOT PEDAL		1
536	2322704	SPRING, LARGE SHORT SS		7
538	2203710	BUTTON,LFT STR w/TRIM UP ARROW		1
540	2203711	BUTTON,RGT STR w/TRIM UP ARROW		1
542	2203715	BUTTON, MOMENTARY/STOW-DEPLOY		1
544	2323715	BUTTON,MOM/CON,FT PEDAL		1
546	2323725	BUTTON,AP,FT PEDAL		1
548	2203720	BUTTON, SPOT LOCK,ULTERRA/TRRV		1
550	2203725	BUTTON, MODE, ULTERRA		1
552	2200200	COVER,HEEL TOE FOOT PEDAL		1
554	2205605	DECAL, 3 INDICATORS, ULTERRA		1
556	2324401	PEDAL,HEEL/TOE FOOT PEDAL		1
558	2322714	SPRING (LEE #LC-029E-4-S) SS		1
560	2328600	FLEX FINGER, FOOT PEDAL		1
562	2321300	CLAMP-LEFT, FT PEDAL		1
564	2223430	SCREW-#8x3/4 PPH,TYPE 25,SS		2
566	2323710	BUTTON,MOM LEFT,FT PEDAL		1
568	2321300	CLAMP-LEFT, FT PEDAL		1
570	2223430	SCREW-#8x3/4 PPH,TYPE 25,SS		2
572	2322706	SPRING-BARREL SS		2
574	2323420	SCREW-#8-18 X 3/8" PFH SS TY B		2
576	2301310	SCREW-#8-18 X 1/2 (SS)*		11
578	2325110	PAD, FOOTPEDAL		5

- ▲ Not shown on Parts Diagram.
- ✘ This part is included in an assembly and cannot be ordered individually.
- ◆ Only available with models factory installed with i-Pilot.
- Only available with models factory installed with i-Pilot Link.

- ✚ Only available with models factory installed with Universal Sonar.
- ➔ Only available with models factory installed with Built-in MEGA Down Imaging.
- * Only available with models factory installed with Built-in MEGA Side Imaging.

PARTS DIAGRAM & PARTS LIST



ULTRERRA MOUNT

Mount Parts Diagram

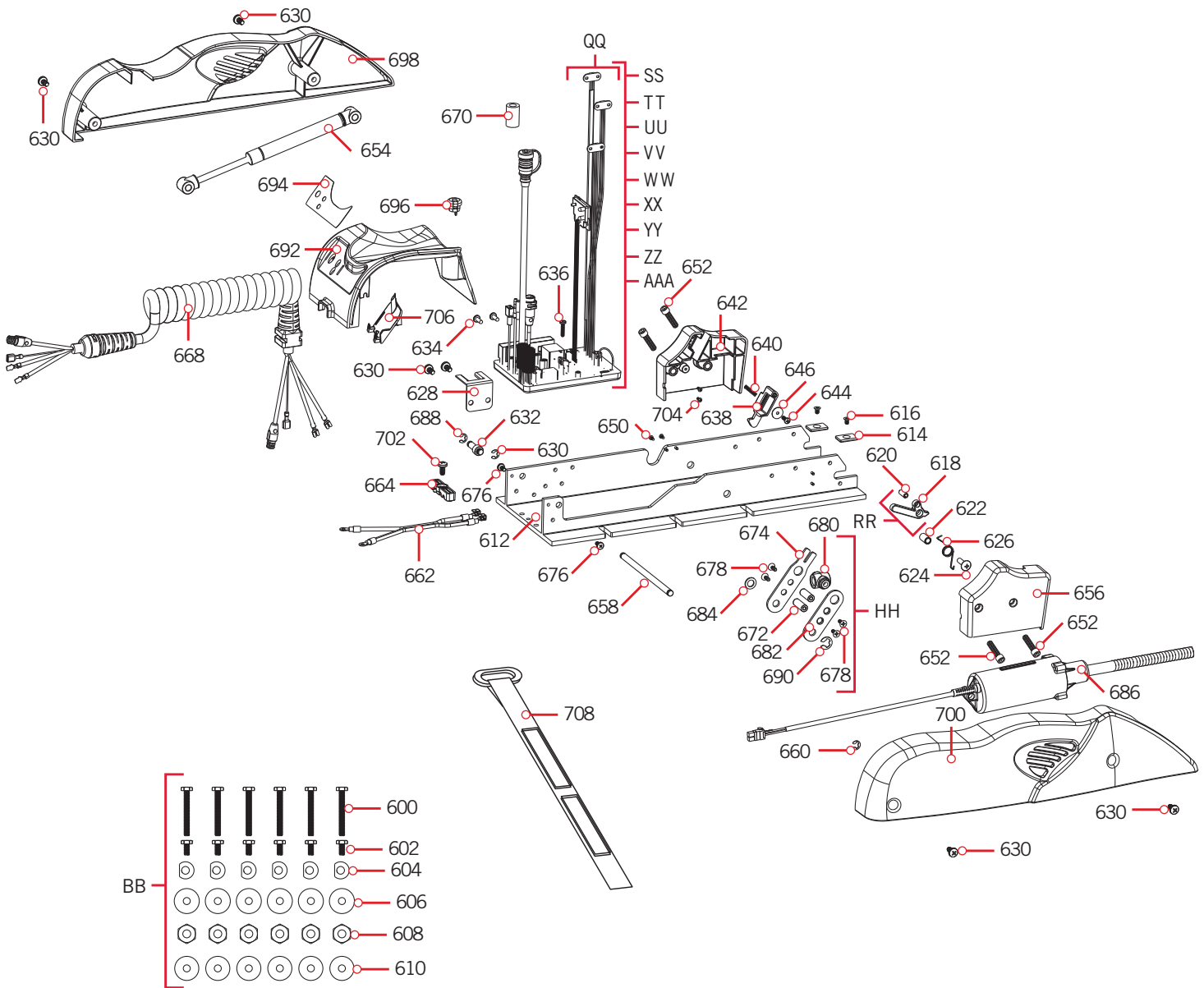

PARTS DIAGRAM & PARTS LIST

Mount Parts List

Assembly	Part #	Description	Notes	Quantity
BB	2994917	BAG ASSY, ULTERRA MTG HARDWARE		1
QQ	2880350	SENSOR WIRE W/BUTT CONNECTORS		1
RR	2777900	CAM W/MAGNET, SPRING PIN		1
SS	2774080	MAIN CTRL BD, US/AU/CA, 24V, 60"	*80LB THRUST* *60*	1
TT	2774081	MAIN CTRL BD, US/AU/CA, 24V, 45"	*80LB THRUST* *45*	1
UU	2774082	MAIN CTRL BD, US/AU/CA, 36V, 60"	*112LB THRUST* *60*	1
VV	2774083	MAIN CTRL BD, US/AU/CA, 36V, 45"	*112LB THRUST* *45*	1
WW	2774084	MAIN CTRL BD, EUR, 24V, 60"	*80LB THRUST* *60* *M SKU EUROPE*	1
XX	2774085	MAIN CTRL BD, EUR, 24V, 45"	*80LB THRUST* *45* *M SKU EUROPE*	1
YY	2774086	MAIN CTRL BD, EUR, 36V, 60"	*112LB THRUST* *60* *M SKU EUROPE*	1
ZZ	2774087	MAIN CTRL BD, EUR, 36V, 45"	*112LB THRUST* *45* *M SKU EUROPE*	1
AAA	2774091	MAIN CTRL BD, US/AU/CA, 36V, 72"	*112LB THRUST* *72*	1
HH	2774201	TILT BRACKET ASSEMBLY		1
Item	Part #	Description	Notes	Quantity
600	2203430	SCREW-1/4-20 X 2.0 HHCS SS		6
602	2203431	SCREW-1/4-20 X 0.5 HHCS SS		6
604	2201725	WASHER-CLIPPED, 1/4", 1.00" OD		6
606	2261713	WASHER-1/4 FLAT 18-8 SS		6
608	2263103	NUT-1/4-20 NYLOCK SS		6
610	2301720	WASHER-MOUNTING - RUBBER		6
612	2201901	BASE, MACHINED, FW		1
614	2205105	PAD, STOP		2
616	2203420	SCREW-#10-24 X 5/16 PFH		2
618	2207900	CAM, PIN SENSOR w/MAGNET		1
620	2262632	PIN-SPRING 1/4" X 5/8" SS		1
622	2201702	SPACER, PIN SENSOR		1
624	9280710	HDW SCR 1/4 20X7/8 TRUSS PHIL		1
626	2042711	SPRING-TORSION, SS		1
628	2200821	CLIP-CORD, ZP		1
630	2323404	SCREW-1/4-20 X 1/2" T-L ZP		4
632	2202902	STANDOFF, OIL DAMPENER		1
634	2323406	SCREW-#10-24 X .50 CRPH SS		2
636	2373487	SCREW-#8-32 X 3/4" PPH MACH SS		1
638	2203700	PLUNGER, RAMP w/MAGNET		1
640	2202703	SPRING, PLUNGER-RAMP		1

- ▲ Not shown on Parts Diagram.
- ✳ This part is included in an assembly and cannot be ordered individually.
- ◆ Only available with models factory installed with i-Pilot.
- Only available with models factory installed with i-Pilot Link.

- ⊕ Only available with models factory installed with Universal Sonar.
- ➔ Only available with models factory installed with Built-in MEGA Down Imaging.
- * Only available with models factory installed with Built-in MEGA Side Imaging.

PARTS DIAGRAM & PARTS LIST



Item	Part #	Description	Notes	Quantity
642	2203916	RAMP-MOTOR, LEFT, 80#		1
	2203917	RAMP-MOTOR, LEFT, 112#		1
644	2301310	SCREW-#8-18 X 1/2 (SS)*		1
646	2201722	WASHER-#6, .625 OD, ZP STEEL		1
648	2373440	SCREW-#4-24 X 1/4 PHCR SS TY B		2
650	2053411	SCREW-#4-40 X 1/4 PPH ZP		4
652	2263453	SCREW-1/4-20 X 1" SHCS S/S		4
▲	2200825	CLIP, SENSOR CABLE		2
654	2208800	DAMPER, HYBRID, 80#		1
	2208802	DAMPER, HYBRID, 112#		1
656	2203911	RAMP-MOTOR, RIGHT, 80#		1
	2203912	RAMP-MOTOR, RIGHT, 112#		1
658	2202606	PIN, ACTUATOR, ZP		1
660	2263006	E-RING,5/16,S/S GAS ASSIST		1
662	2090651	LEADWIRE,10 GA,PD/GENESIS		1
664	2321310	STRAIN RELIEF		1
666	2263453	SCREW-1/4-20 X 1" SHCS S/S		1
668	2991272	COIL CORD ASY 54/60" U.SONAR		1
	2991276	COIL CORD ASY 72" U.SONAR		1
670	2307313	BEAD-FERRITE		1
672	2202901	STANDOFF, LIFT ARM		2
674	2204201	ARM-LIFT, INNER, ZP		1
676	2383447	SCREW-#10-32 X 3/8" PPH SS		2
678	2203410	SCREW-#10-32 X .5"		4
680	2203100	NUT, TILT MOTOR		1
682	2204206	ARM-LIFT, OUTER, ZP		1
684	2321702	WASHER-FLAT .375 NYLON		1
686	2997813	ASSEMBLY, TILT MOTOR		1
688	2263006	E-RING,5/16,S/S GAS ASSIST		1
690	2263011	E-RING 3/8 DIA. SHAFT*		1
692	2206510	HOUSING-CONTROL, BLACK		1
694	2205602	DECAL, B.METER/CON/PWR FW, BLK		1
696	2202910	STRAIN RLF,HEYC SR 6N3-4		1
698	2203907	SIDEPLATE, LEFT		1
700	2203902	SIDEPLATE, RIGHT		1
702	2323404	SCREW-1/4-20 X 1/2" T-L ZP		1
▲	2256300	TIE WRAP-5.5" BLACK		2

- ▲ Not shown on Parts Diagram.
- ✳ This part is included in an assembly and cannot be ordered individually.
- ◆ Only available with models factory installed with i-Pilot.
- Only available with models factory installed with i-Pilot Link.

- ✚ Only available with models factory installed with Universal Sonar.
- ➔ Only available with models factory installed with Built-in MEGA Down Imaging.
- * Only available with models factory installed with Built-in MEGA Side Imaging.



PARTS DIAGRAM & PARTS LIST



Item	Part #	Description	Notes	Quantity
▲	2052510	CABLE CLAMP, 3/16", NYLON		2
704	2373440	SCREW-#4-24 X 1/4 PHCR SS TY B		2
706	2200823	CLIP, POWER BUTTON		1
708	2203801	STRAP, HOLD DOWN, ULTERRA		1

- ▲ Not shown on Parts Diagram.
- ✘ This part is included in an assembly and cannot be ordered individually.
- ◆ Only available with models factory installed with i-Pilot.
- Only available with models factory installed with i-Pilot Link.

- ⊕ Only available with models factory installed with Universal Sonar.
- ➔ Only available with models factory installed with Built-in MEGA Down Imaging.
- * Only available with models factory installed with Built-in MEGA Side Imaging.



RECOMMENDED ACCESSORIES

› ON-BOARD & PORTABLE BATTERY CHARGERS

Stop buying new batteries and start taking care of the ones you've got. Many chargers can actually damage your battery over time – creating shorter run times and shorter overall life. Digitally controlled Minn Kota chargers are designed to provide the fastest charge that protect and extend battery life.



MK212PC



MK210D



MK110PD

› TALON SHALLOW WATER ANCHOR

Introducing the all-new, sleek redesigned Talon. Talon is the only shallow water anchor with up to 15' of anchoring depth, multiple anchoring modes, and control from the bow, transom, console, remote or mobile device.



BUILT-IN WORK LIGHT

Lets you tie lines and work from the transom any time of day — or night. Includes both white and blue LED lights with three brightness settings.



UP TO 15' DEEP

Control more water and catch more fish with the first 15' shallow water anchor.



MORE CONTROL OPTIONS

- Control Panel
- Wireless Remote
- Mobile App
- Wireless Foot Switch
- Humminbird® Connectivity
- i-Pilot® & i-Pilot Link™ Remote



BLUETOOTH® CONNECTIVITY

Lets you control Talon from your mobile device and easily update it. Also opens up communication to other control options.

› MINN KOTA ACCESSORIES

We offer a wide variety of trolling motor accessories, including:

- 60-Amp Circuit Breaker
- Mounting Brackets
- Stabilizer Kits
- Extension Handles
- Battery Connectors
- Battery Boxes
- Quick Connect Plugs



minnkotamotors.com



Part #2207111

Minn Kota Consumer & Technical Service
Johnson Outdoors Marine Electronics, Inc.
PO Box 8129
Mankato, MN 56001

121 Power Drive
Mankato, MN 56001
Phone (800) 227-6433
Fax (800) 527-4464



©2019 Johnson Outdoors Marine Electronics, Inc.
All rights reserved.

ECN 40130

Rev N

12/19