

SCALE 0.500

REV. ECN NO.		REVISIONS	DESCRIPTION	BY	DATE
A	44387		RELEASE FOR PRODUCTION	NMB	10NOV2023

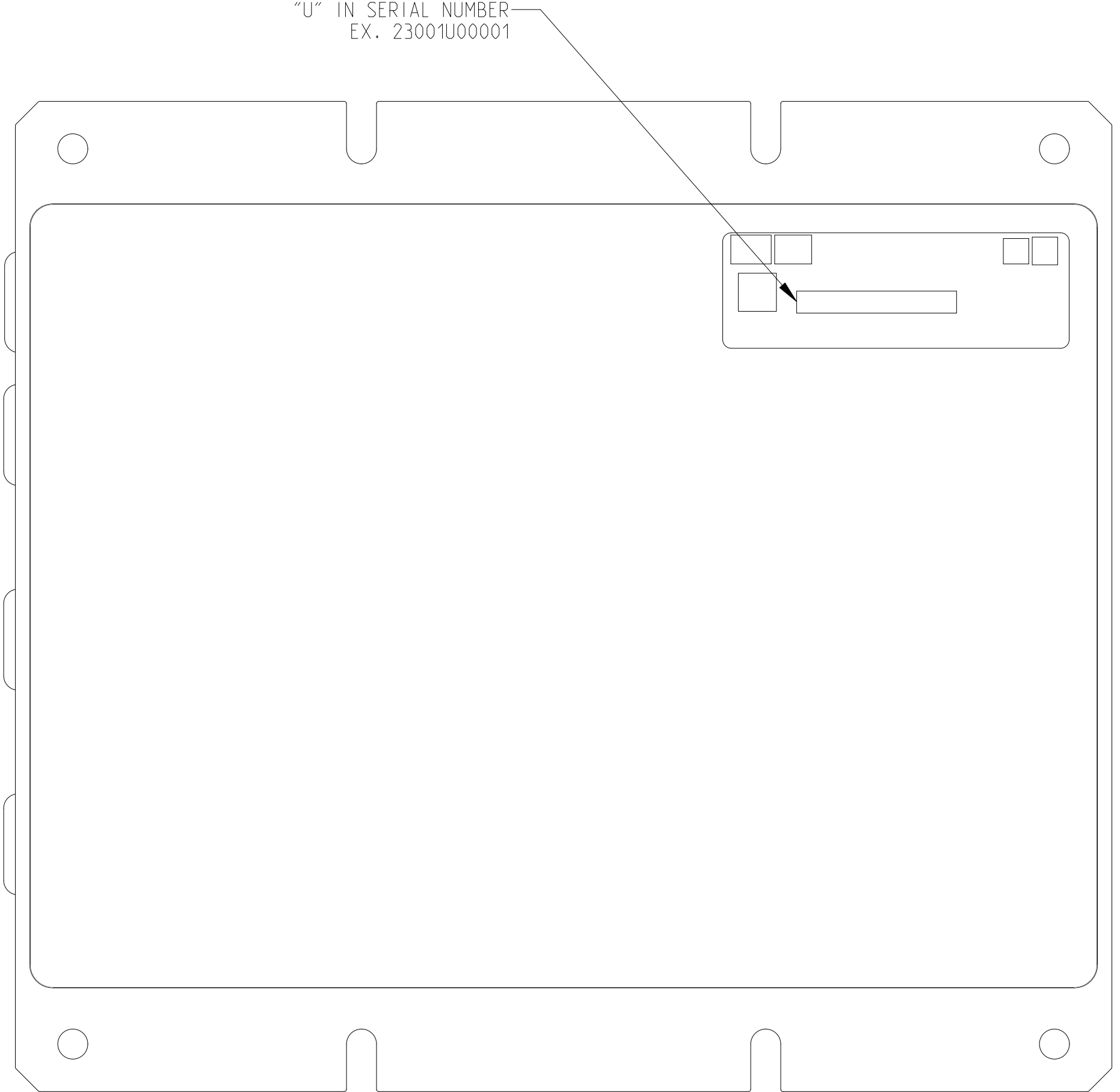
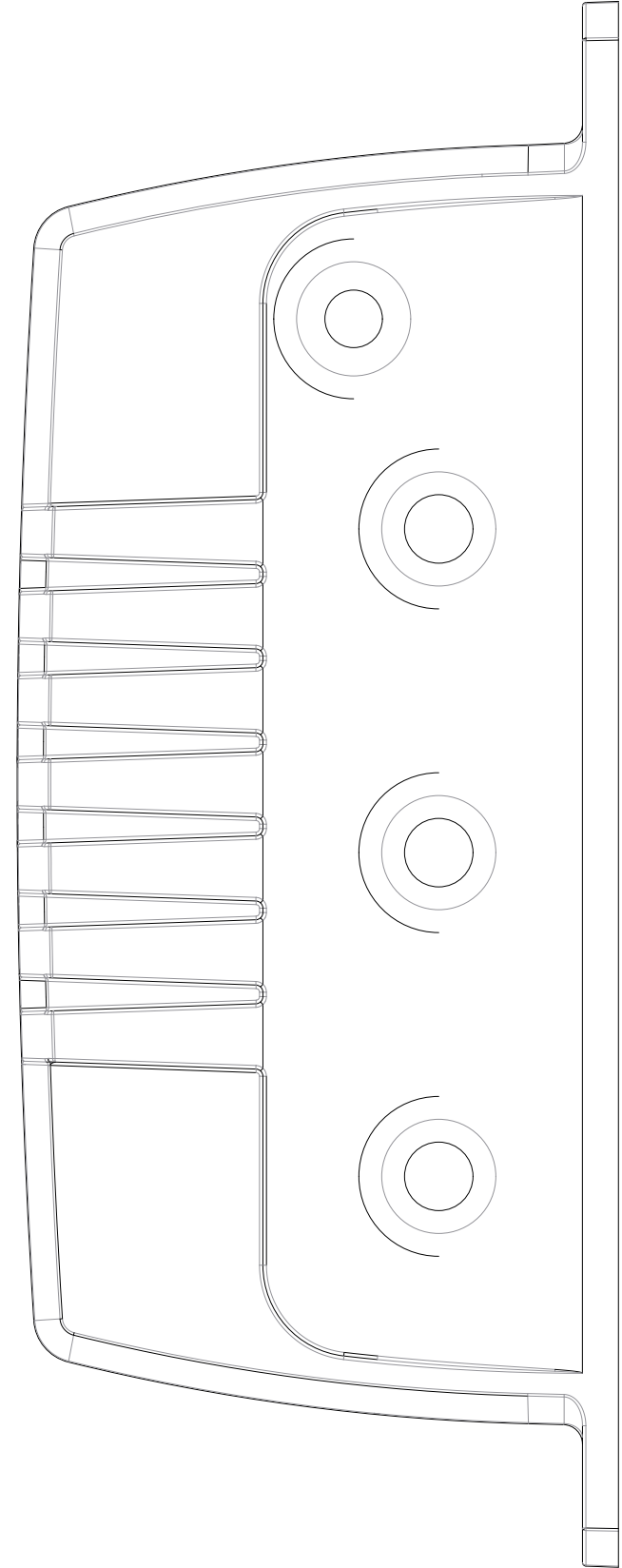
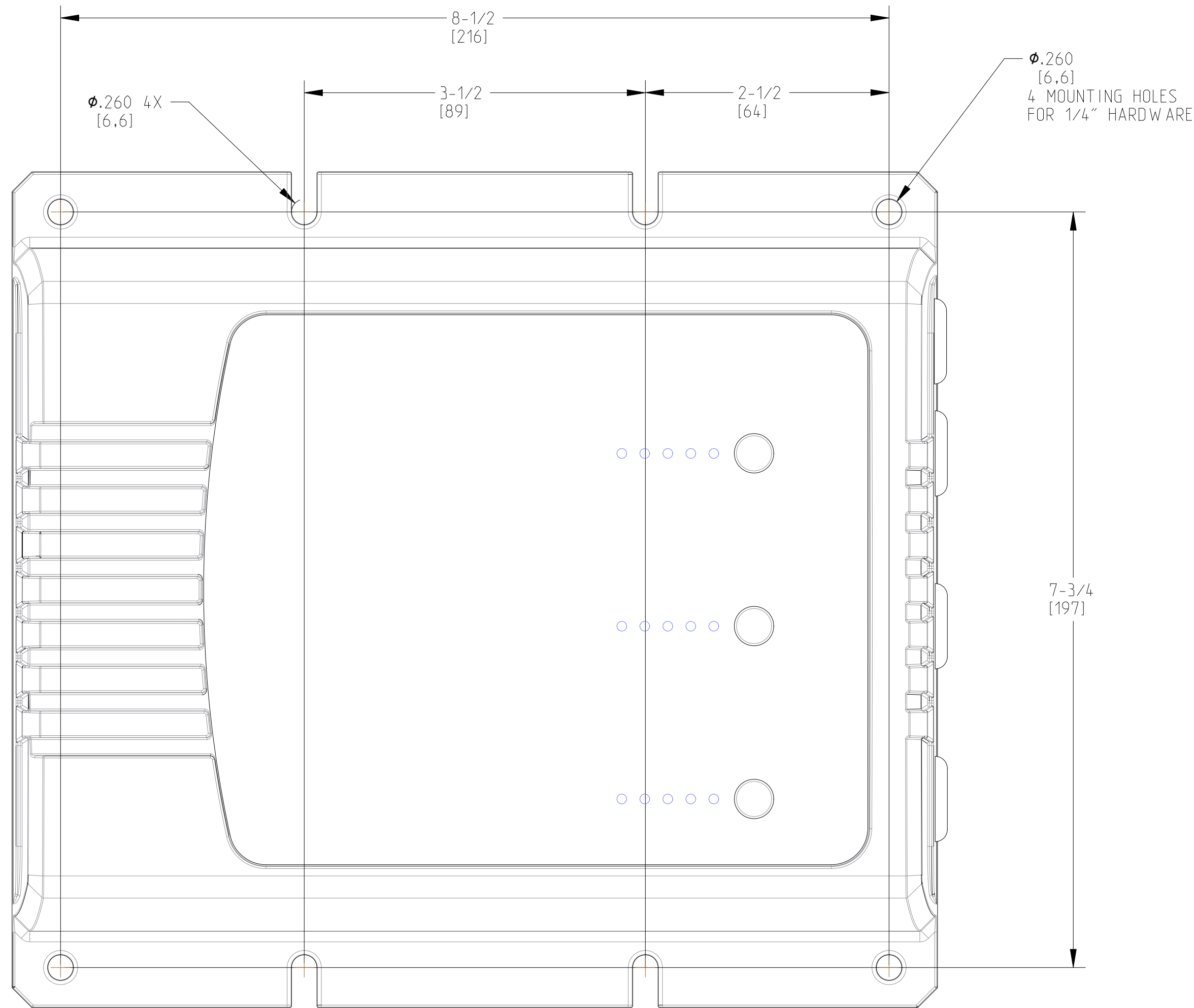

CAUTION: ALWAYS WEAR SAFETY GLASSES AND GLOVES. DISCONNECT ALL POWER BEFORE BEGINNING ANY WORK OR MAINTENANCE. JOHNSON OUTDOORS INC. IS NOT RESPONSIBLE FOR ANY DAMAGE DUE TO IMPROPER RIGGING OR INSTALLATION. IF YOU DO NOT HAVE THE SKILLS, EXPERIENCE AND TOOLS TO PERFORM THE FOLLOWING MAINTENANCE AND REPAIRS, WE RECOMMEND YOU SEEK THE HELP OF AN AUTHORIZED SERVICE CENTER. OR CONTACT OUR TECHNICAL SERVICE DEPARTMENT BY DIALING 800-227-6433.

CUSTOMER DRAWING

JOHNSON OUTDOORS
MARINE ELECTRONICS, INC.

DRAWING NAME: MK345PCL CHARGER D SIZE: A

DRAWING NO: CD0026 SHEET 1 OF 2 U/A: IN. (MM) REV: A

REVISIONS				
REV.	ECN NO.	DESCRIPTION	BY	DATE
		SEE SHEET 1		

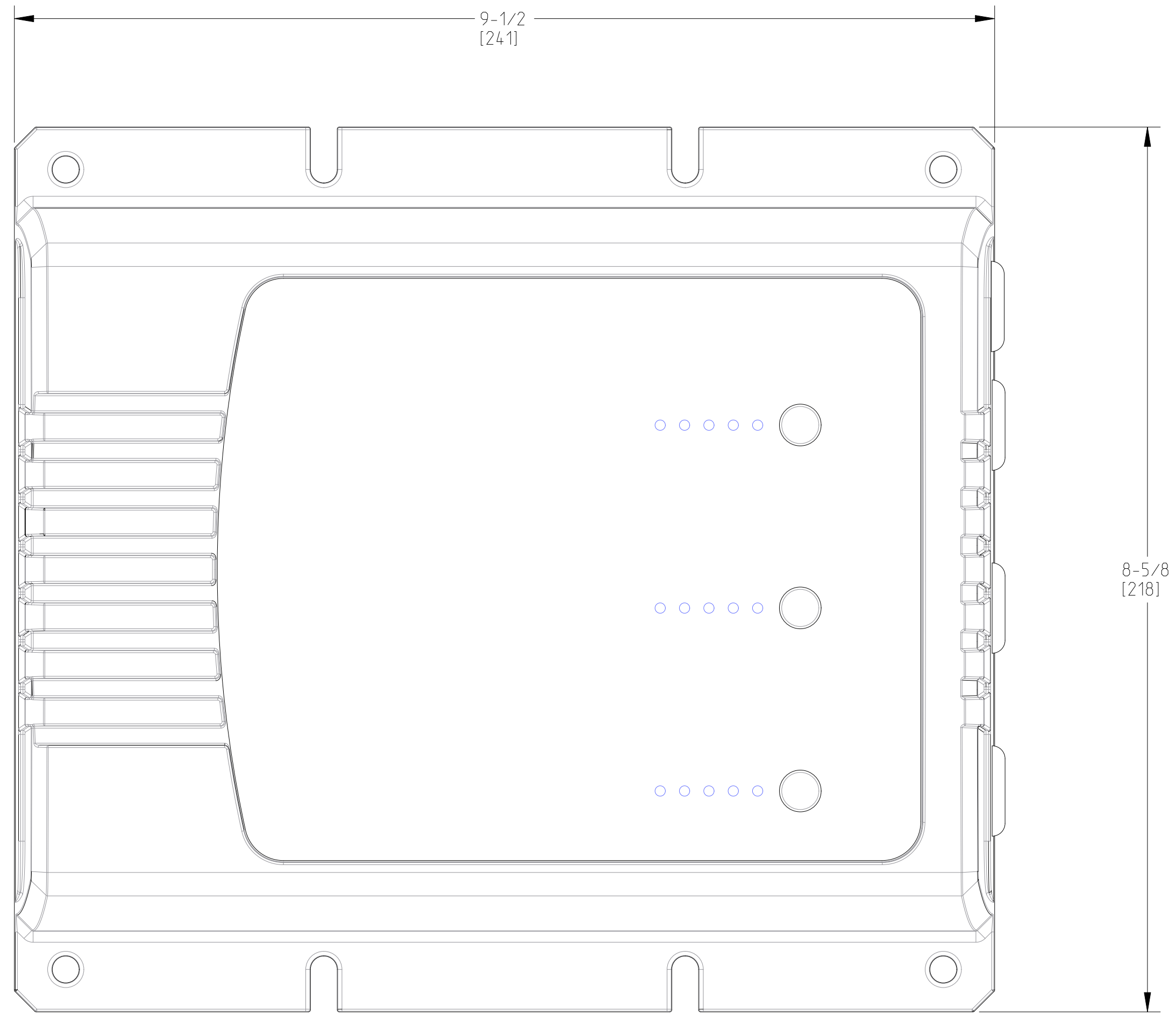

MAINTAIN SIX INCHES OF CLEARANCE ON ALL SIDES OF CHARGER FOR PROPER AIR CIRCULATION AND COOLING



CAUTION: ALWAYS WEAR SAFETY GLASSES AND GLOVES. DISCONNECT ALL POWER BEFORE BEGINNING ANY WORK OR MAINTENANCE. JOHNSON OUTDOORS INC. IS NOT RESPONSIBLE FOR ANY DAMAGE DUE TO IMPROPER RIGGING OR INSTALLATION. IF YOU DO NOT HAVE THE SKILLS, EXPERIENCE AND TOOLS TO PERFORM THE FOLLOWING MAINTENANCE AND REPAIRS, WE RECOMMEND YOU SEEK THE HELP OF AN AUTHORIZED SERVICE CENTER. OR CONTACT OUR TECHNICAL SERVICE DEPARTMENT BY DIALING 800-227-6433.

CUSTOMER DRAWING

JOHNSON OUTDOORS
MARINE ELECTRONICS, INC.

DRAWING NAME: MK345PCL CHARGER

DRAWING NO: CD0026

SHEET 2 OF 2

U/A: IN. (MM)

REV: A

D SIZE