

CD0024

REV. ECN NO.		REVISIONS DESCRIPTION	BY	DATE
A	44082	RELEASE FOR PRODUCTION	JRL	29JUN2023

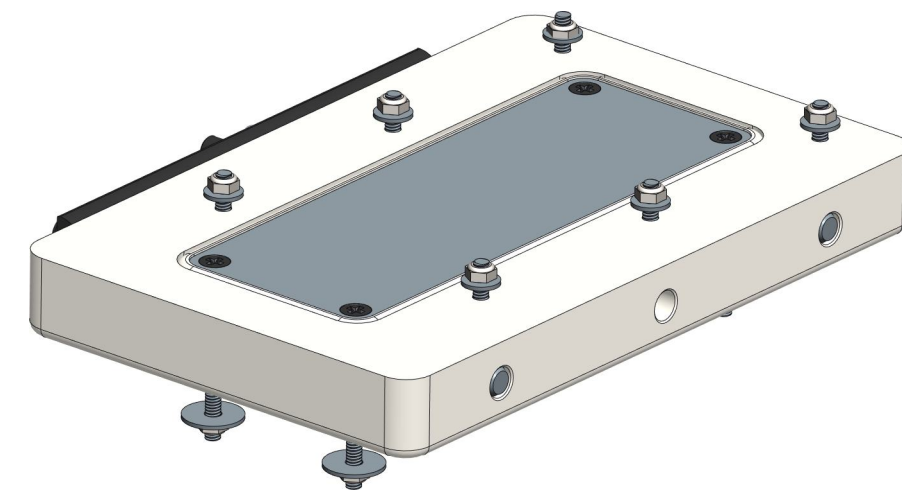

SCALE 0.333

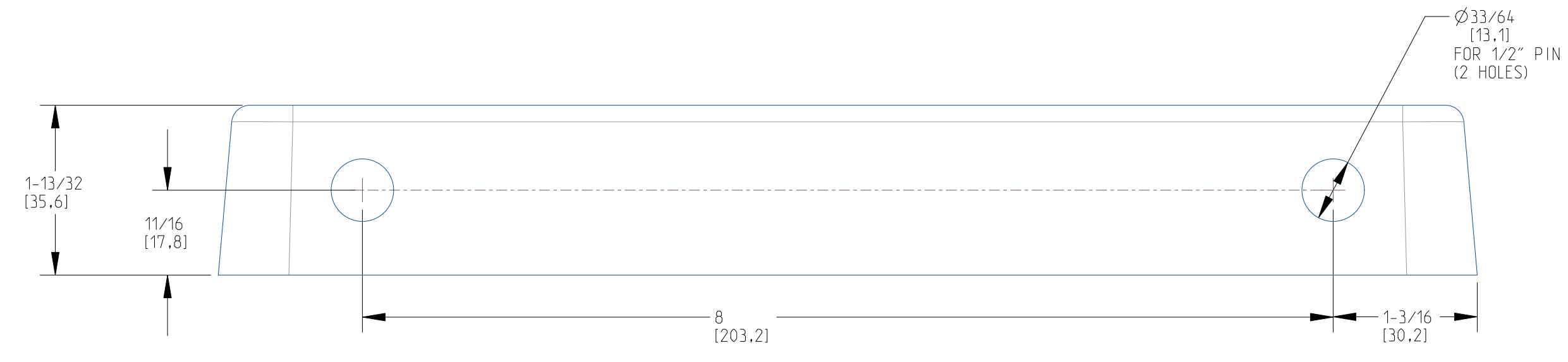
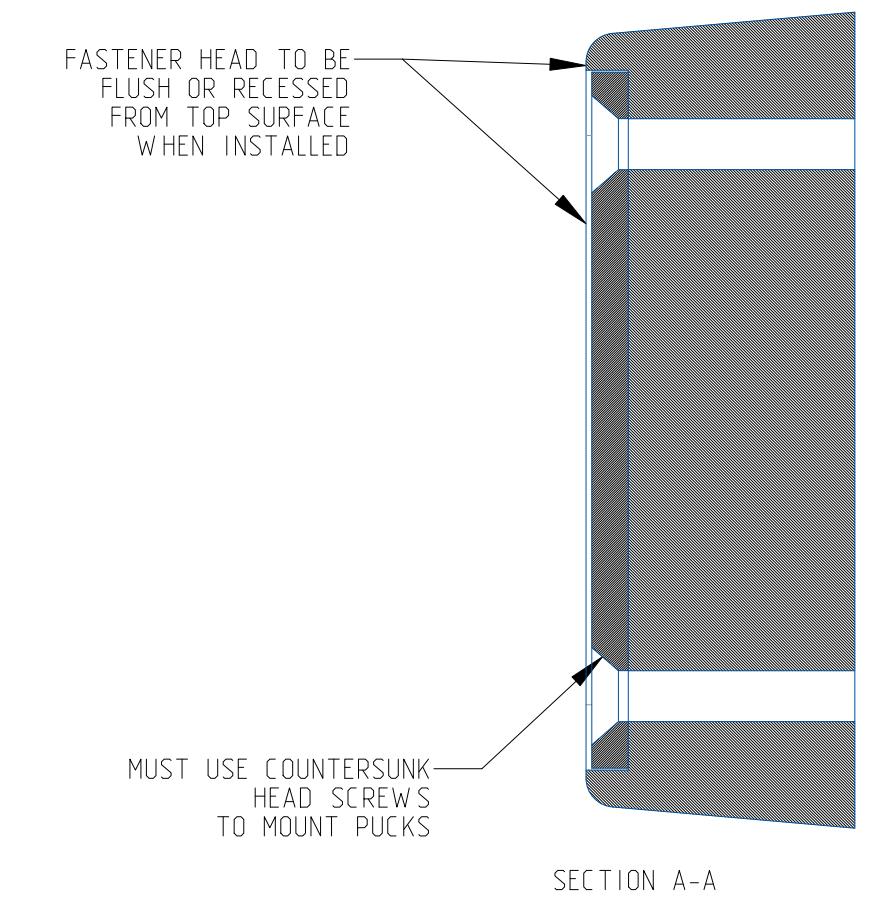

NOTES:
 - RECOMMENDED DRILL SIZE 9/32
 - MOUNTING FASTENERS TO BE MINNKOTA SUPPLIED 1/4-20 WITH COUNTERSUNK HEADS

CAUTION: ALWAYS WEAR SAFETY GLASSES AND GLOVES. DISCONNECT ALL POWER BEFORE BEGINNING ANY WORK OR MAINTENANCE. JOHNSON OUTDOORS INC. IS NOT RESPONSIBLE FOR ANY DAMAGE DUE TO IMPROPER RIGGING OR INSTALLATION. IF YOU DO NOT HAVE THE SKILLS, EXPERIENCE AND TOOLS TO PERFORM THE FOLLOWING MAINTENANCE AND REPAIRS, WE RECOMMEND YOU SEEK THE HELP OF AN AUTHORIZED SERVICE CENTER. OR CONTACT OUR TECHNICAL SERVICE DEPARTMENT BY DIALING 800-227-6433.

CUSTOMER DRAWING			
JOHNSON OUTDOORS MARINE ELECTRONICS, INC.			
DRAWING NAME: RTA-62/MKA-64		D size: A	
DRAWING NO: CD0024	SHEET 1 OF 2	U/A: IN. [MM]	REV: A

D

C

B

A

CD0024

REV. ECN NO.		REVISIONS	BY	DATE
		DESCRIPTION		
		SEE SHEET 1		

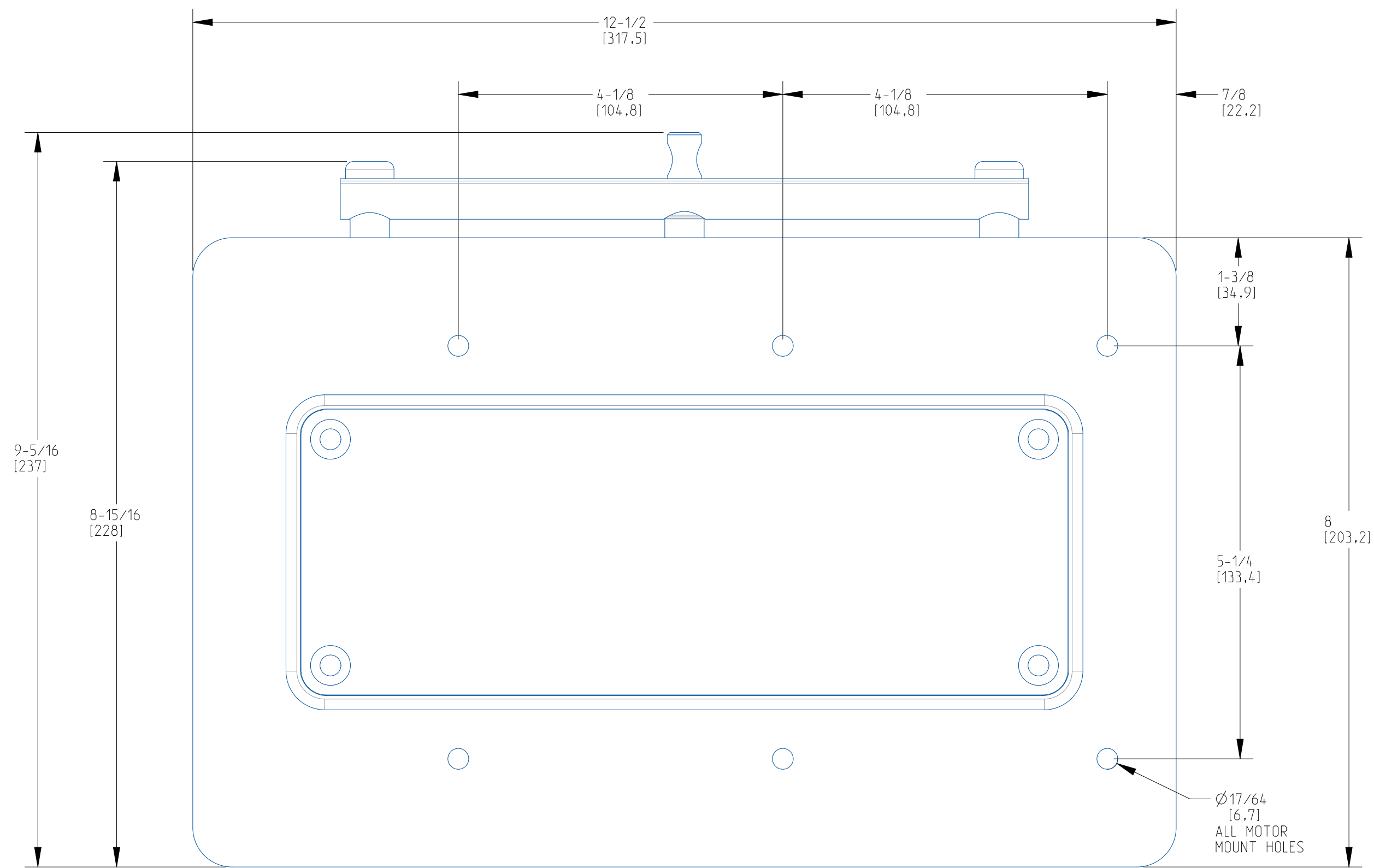
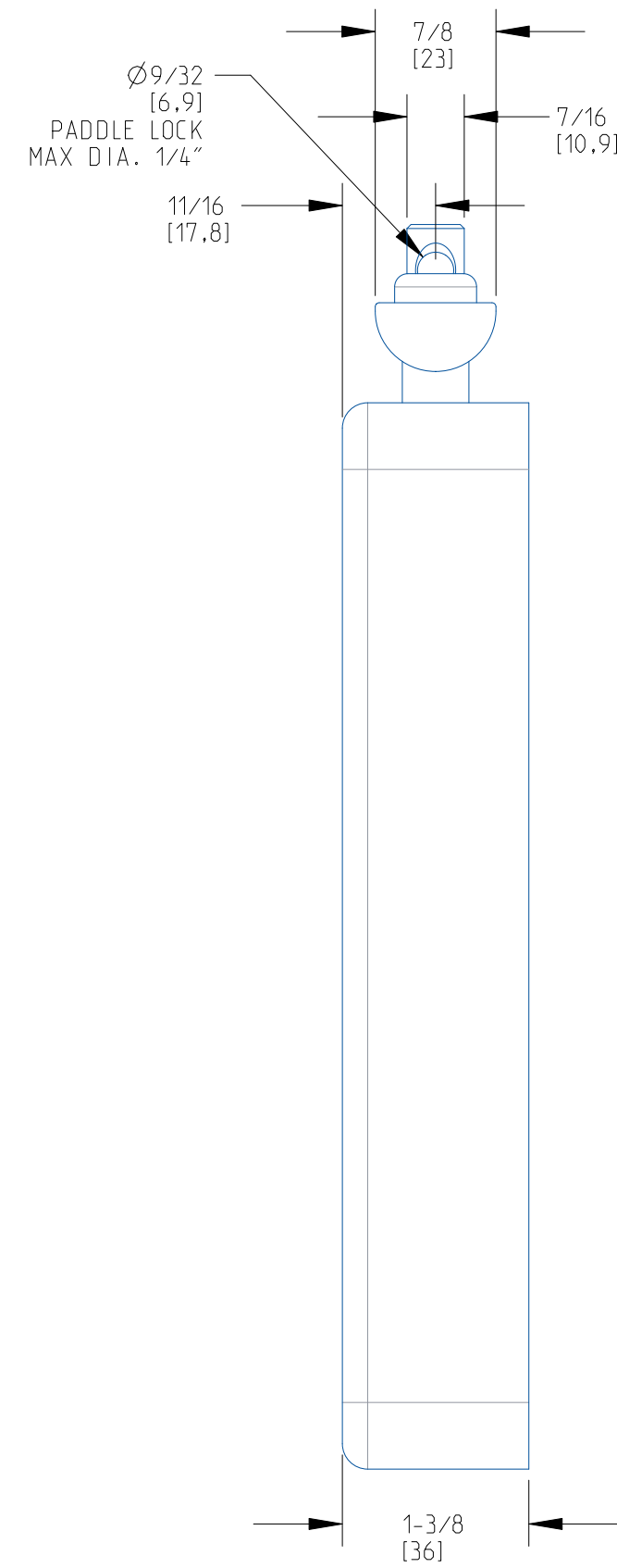

MOTOR SECURED WITH DRAWBAR

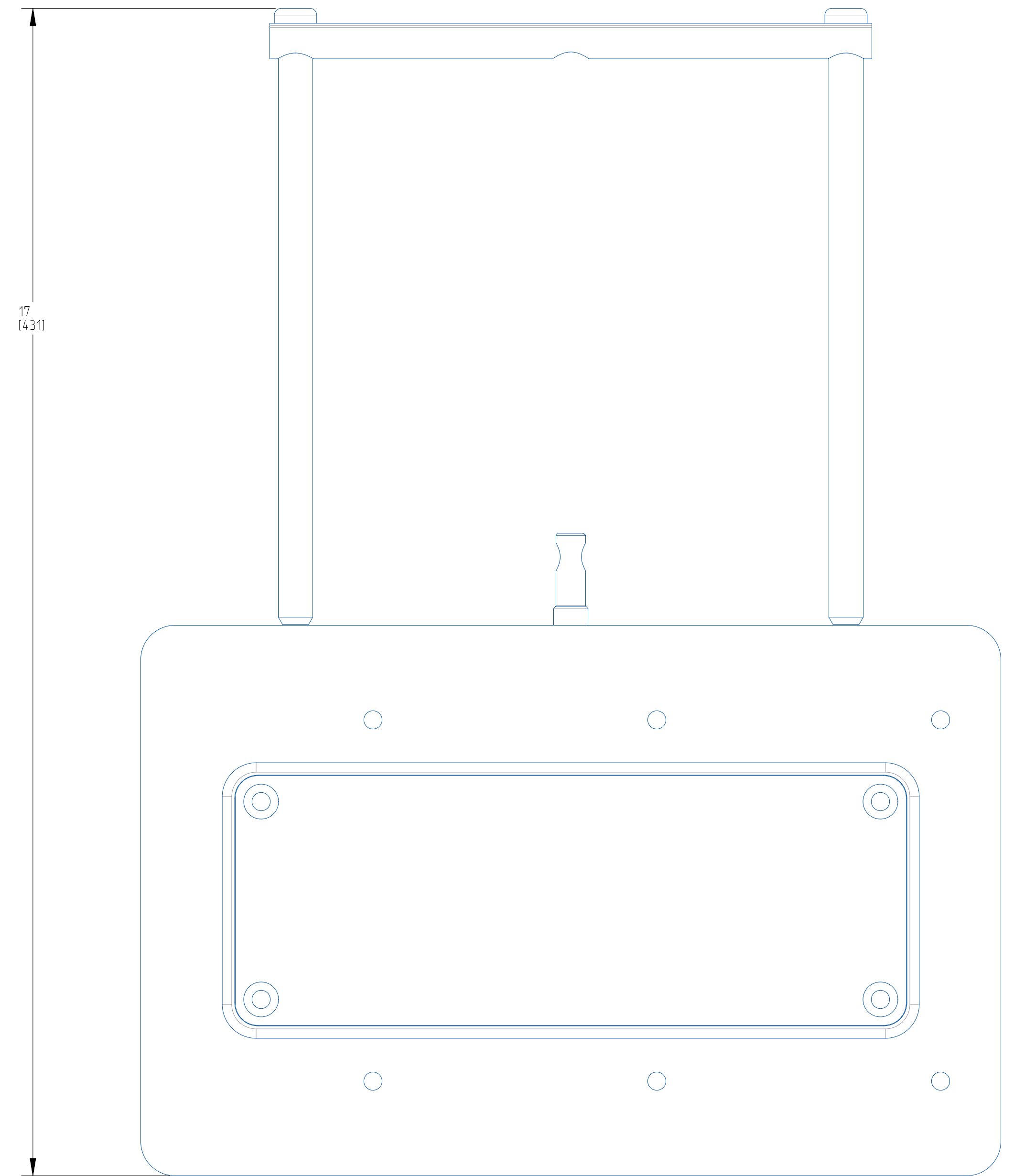

DRAWBAR REMOVAL CLEARANCE

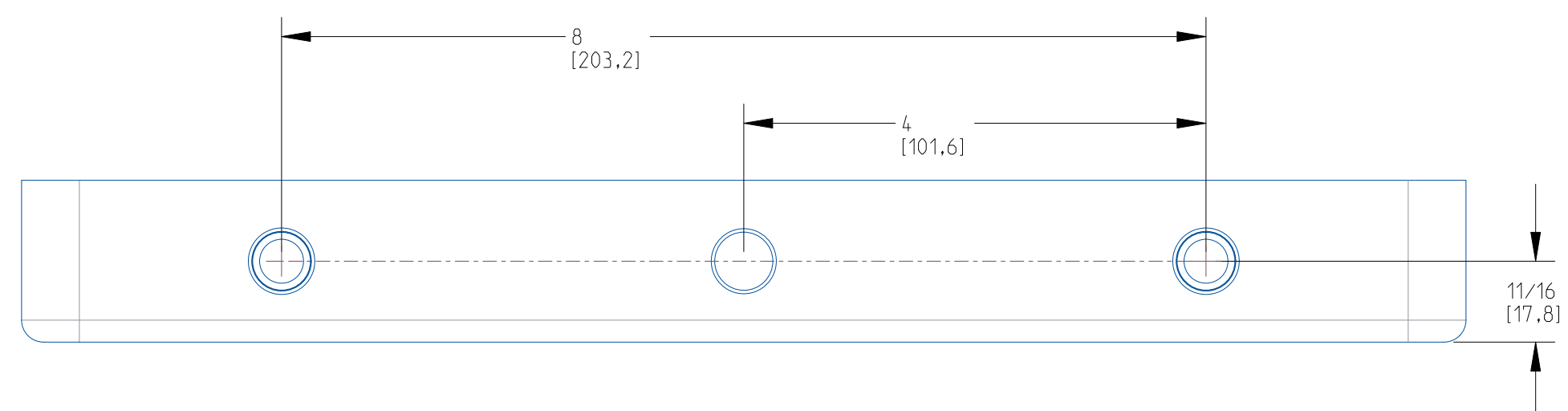

CUSTOMER DRAWING

JOHNSON OUTDOORS
MARINE ELECTRONICS, INC.

DRAWING NAME: RTA-62/MKA-64

DRAWING NO: CD0024

SHEET 2 OF 2

U/A: IN. [MM]

REV: A

D SIZE

CAUTION: ALWAYS WEAR SAFETY GLASSES AND GLOVES. DISCONNECT ALL POWER BEFORE BEGINNING ANY WORK OR MAINTENANCE. JOHNSON OUTDOORS INC. IS NOT RESPONSIBLE FOR ANY DAMAGE DUE TO IMPROPER RIGGING OR INSTALLATION. IF YOU DO NOT HAVE THE SKILLS, EXPERIENCE AND TOOLS TO PERFORM THE FOLLOWING MAINTENANCE AND REPAIRS, WE RECOMMEND YOU SEEK THE HELP OF AN AUTHORIZED SERVICE CENTER. OR CONTACT OUR TECHNICAL SERVICE DEPARTMENT BY DIALING 800-227-6433.