

# TALON SPACER BLOCK KIT 1810210

THE SPACER BLOCK WILL WORK WITH COMPATIBLE JACK PLATES ALONG WITH OTHER DESIGNS. DRILLING HOLES TO ACCEPT THE SIDE MOUNT BRACKETS AND/OR SPACER BLOCK MAY VOID YOUR MANUFACTURER'S WARRANTY. MINN KOTA IS NOT RESPONSIBLE FOR DAMAGES THAT MAY RESULT.

THE SPACER BLOCK KIT PROVIDES 2" OF CLEARANCE WHEN MOUNTING A "J" STYLE BRACKET TO THE SIDE OF A COMPATIBLE JACK PLATE WITH MOUNTING OBSTRUCTIONS.

## INSTALLATION : ATLAS JACK PLATES

**NOTE:** Some earlier Atlas hydraulic jack plates do not have mounting holes drilled from the factory. Jackplates without mounting holes will have to be drilled, refer to your jack plate instruction sheet for further details.

### *ATLAS HYDRAULIC WITH HOLES:*

1. Locate the (2) 1/2" mounting holes on either the port or starboard side of the jack plate  
NOTE: Holes may be located under the side decals.
2. Align the holes in the adapter bracket with the holes in the jack plate and spacer block kit.
3. Fasten the adapter bracket to the jackplate with the longer hardware provided with the spacer block kit.

### *ATLAS HYDRAULIC WITHOUT HOLES:*

NOTE: Drilling (2) 1/2" mounting holes is required for this installation. Drilling mounting holes thru the Atlas jack plate **WILL NOT** void your manufacturer's warranty.

1. Position the spacer block against the side of the jack plate (port or starboard) and slide towards outboard until it touches the main jack plate support. **See Photo 1.**
2. Mark the (2) mounting holes on the side of the jack plate.
3. Drill (2) 1/2" holes thru the jack plate. Make sure there is nothing on the inside that could get damaged.
4. Align the holes in the adapter bracket with the holes in the jack plate and spacer block kit.
5. Fasten the adapter bracket to the jackplate with the longer hardware provided with the spacer block kit.

### **LIMITED TWO-YEAR WARRANTY:**

Johnson Outdoors Inc. warrants to the original purchaser that the purchaser's Talon adapter bracket is free from defects in materials and workmanship appearing within two (2) years after the date of purchase.

This warranty does NOT apply in the following circumstances: (1) when the product has been installed, combined, altered, adjusted, or handled in a manner other than according to the instructions furnished with the product; (2) when any defect, problem, loss, or damage has resulted from or caused by normal wear and tear, blemishes that do not affect the functionality of the product, or accidents, abuse, alteration, modification, misuse or improper care or maintenance in accordance with the instructions of the owner's manual for the motor.

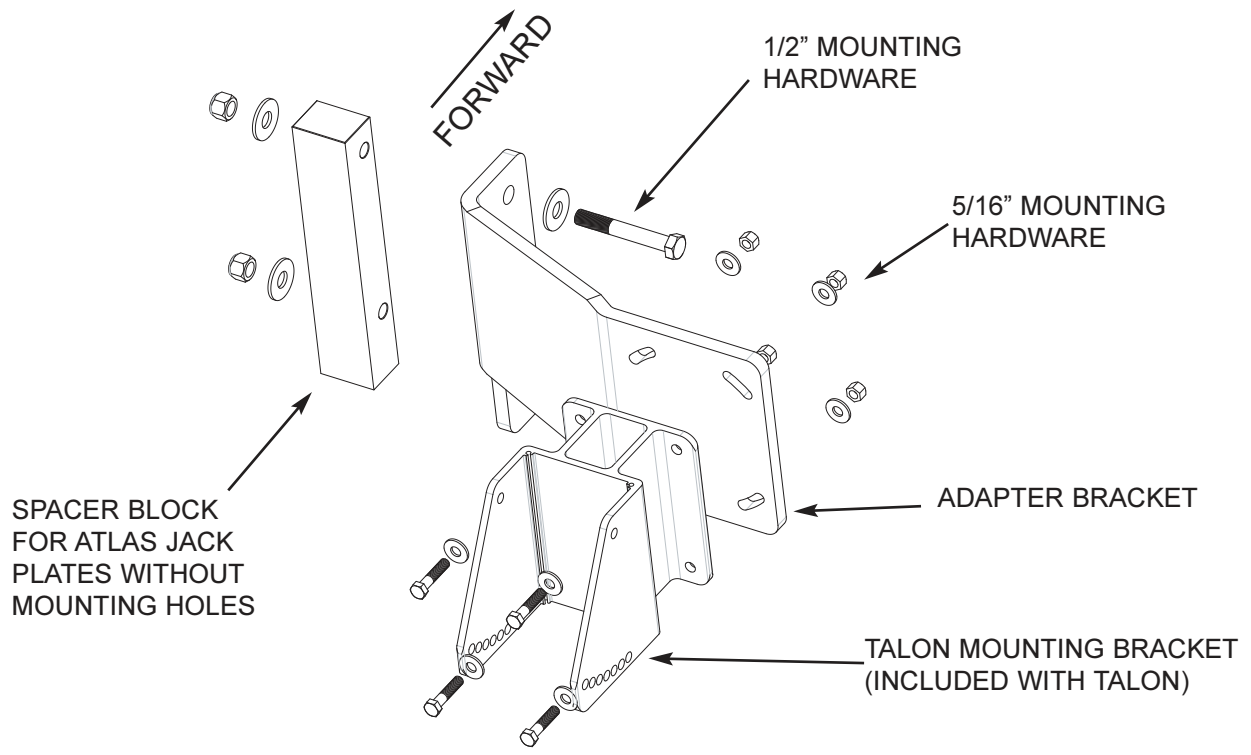

MOUNTING EXAMPLE: 9" OFFSET--STARBOARD SIDE MOUNT BRACKET WITH OPTIONAL SPACER BLOCK

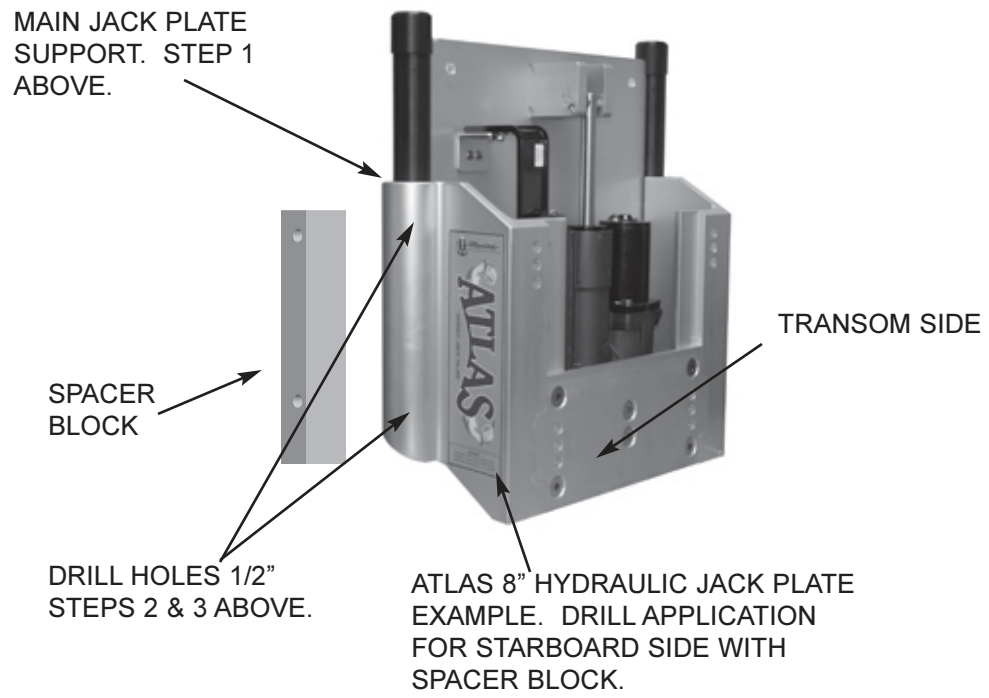

PHOTO 1 - ATLAS HYDRAULIC