

Quick Disconnect Mounting Bracket

531919-1_B

Thank You

Thank you for choosing Humminbird®, the #1 name in fishfinders. Humminbird® has built its reputation by designing and manufacturing top-quality, thoroughly reliable marine equipment. Genuine Humminbird® accessories offer the opportunity to upgrade and expand the capabilities of your Humminbird® product.

Your Humminbird® accessory is designed for trouble-free use in even the harshest marine environment. In the unlikely event that your Humminbird® accessory does require repairs, we offer an exclusive Service Policy - free of charge during the first year after purchase, and available at a reasonable rate after the one-year period. For complete details, see the Warranty section included in this manual.

Contact our Customer Resource Center at **1-800-633-1468** or visit our Web site at humminbird.com.

Installation Overview

Following are instructions for the installation of the Quick Disconnect Mounting Bracket. Before you start installation, we encourage you to read these instructions carefully in order to get the full benefit from your Humminbird® accessory.

If you find that any items are missing from your installation kit, call our Customer Resource Center at **1-800-633-1468** or visit our Web site at humminbird.com.

Supplies: In addition to the hardware supplied with your installation kit, you will need a drill, your control head, the mounting bracket, the connector holder, the power cable, the mounting hardware, a 9/64" drill bit, a 1" hole saw, a Phillips and a flat-head screwdriver, an adjustable wrench, a level, and marine-grade silicone sealant.

NOTE: If you are installing the Speed Sensor accessory (optional), you will also need to purchase the Sonar/Speed Y-Cable. Contact our Customer Resource Center for details at **1-800-633-1468** or visit our Web site at humminbird.com.

Installation

To install the Quick Disconnect Mounting System on your boat, perform the procedures in the following sections.

1. Determine Where to Mount

Begin the installation by determining where to mount the control head. Consider the following to determine the best location:

- To check the location planned for the control head, test run the cables for power, transducer, and optional accessories (speed, Ethernet, etc.).
- There are two ways to route the cables to the unit: through a hole in the mounting surface underneath the mounting bracket, or from a hole outside the mounting bracket. Routing the cables under the mounting bracket provides maximum weather protection; however, this may not be feasible if the area under the control head is inaccessible. In this case, route the cables through a hole at another location and cover with the supplied hole cover.
- The mounting surface should be stable enough to protect the control head from excessive wave shock and vibration, and should provide visibility while in operation.
- The mounting area should allow sufficient room for the unit to pivot and swivel freely, and for easy removal and installation (see illustrations).

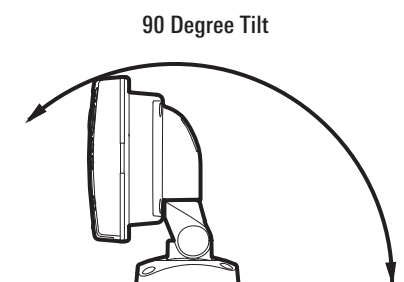
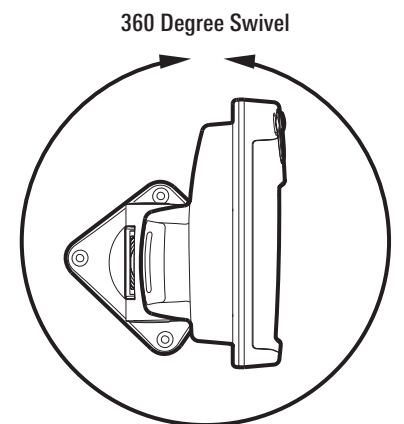

Quick Disconnect Mounting Bracket

531919-1_B

2. Drill the Mounting Holes

1. Set the mounting bracket in place on the mounting surface. Mark the four mounting screw locations with a pencil or a punch.
2. Set the mounting bracket aside, and drill the four mounting holes using a 9/64" drill bit. If you have access to the underside of the mounting surface, mark and drill a 1" hole centered between the four mounting screw holes.

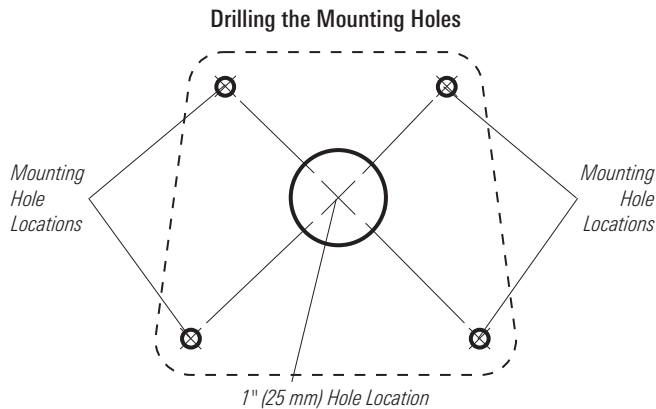

3. Route the Cables Through the Mounting Bracket

- 1a. If the cables must pass through a hole directly beneath the mounting bracket, mark and drill an additional 1" (25 mm) hole centered between the four mounting holes. Route the cables through the grommet, then press the grommet in place around the cables and into the 1"(25 mm) hole. Pass the cables out of the top of the mounting bracket.
- 1b. If the cables cannot be routed directly beneath the mounting bracket, mark and drill a 1" (25 mm) hole that will allow you to run the cables close to the bracket. Pass the cables through the 1" (25 mm) hole, through the mounting base, and out of the top of the mounting bracket. Using needle-nose pliers, break out the tabs on the rear of the mounting base. Place the Hole Cover over the mounting surface hole, then use it to mark the position of the two mounting screws. Remove the Hole Cover, drill the two mounting holes using a 9/64" (3.5 mm) bit, fill them with marine-grade silicone, then replace the Hole Cover and insert the #8 Phillips countersink wood screws. **Hand-tighten only.**

NOTE: Remove the break-out tabs only if the cable hole is not under the mount.

2. Place the mounting bracket on the mounting surface aligned with the drilled holes and fill the mounting holes with marine grade silicone. Insert the four #8 Phillips countersink wood screws into the mounting holes. **Hand-tighten only.**

CAUTION! Do not cut or shorten the transducer cable, and try not to damage the cable insulation. Route the cable as far as possible from any VHF radio antenna cables or tachometer cables to reduce the possibility of interference. If the cable is too short, extension cables are available to extend the transducer cable up to a total of 50'. For assistance, contact the Customer Resource Center at humminbird.com or call 1-800-633-1468 for more information.

CAUTION! Do NOT mount the cables where the connectors could be submerged in water or flooded. If cables are installed in a splash-prone area, it may be helpful to apply dielectric grease to the inside of the connectors to prevent corrosion. Dielectric grease can be purchased separately from a general hardware or automotive store.

Routing the Cables Through the Mounting Bracket

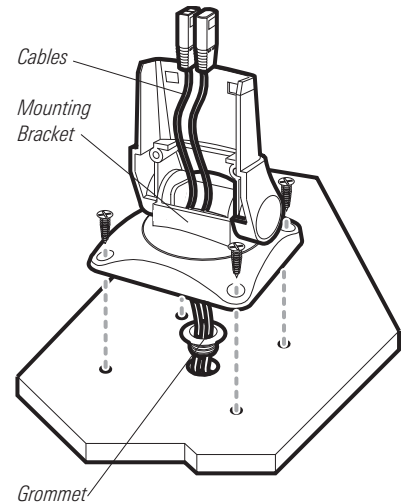

Routing the Cables Through the Hole Not Covered by the Mounting Bracket

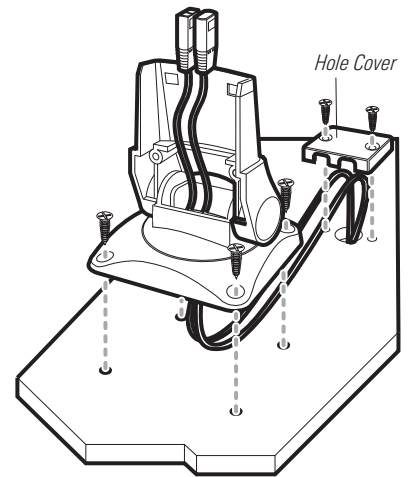

Removing the Break-Out Tabs

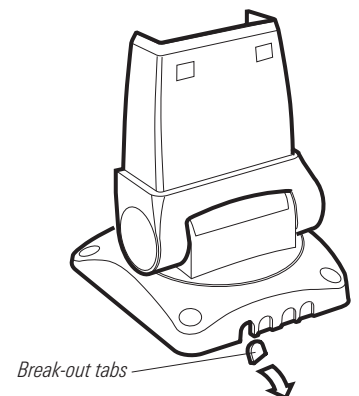

Quick Disconnect Mounting Bracket

531919-1_B

4. Connect the Cable

1. Insert the connectors into the appropriate slots on the connector holder. The cable connectors are labeled, and there are corresponding labels on the connector holder on the rear of the fishfinder. The slots are keyed to prevent reversed installation, and insertion should be easy—do not force the connectors into the slots.

NOTE: If you are installing the Speed Sensor accessory (optional), insert the Sonar/Speed Y-Cable connector into the T2 slot on the connector holder. Then, connect the transducer connector and speed sensor connector to the corresponding connectors on the Y-Cable. The Y-Cable requires a separate purchase.

2. Carefully pull the excess cable from beneath the mounting surface so the connector holder aligns with the mounting holes on the front of the mounting bracket.
3. Snap the support plate to the rear of the connector holder as illustrated.
4. Insert the connector holder into place and use the two #6-32 x 3/4" screws to fasten it to the mounting bracket.

Snapping the Support Plate onto the Connector Holder

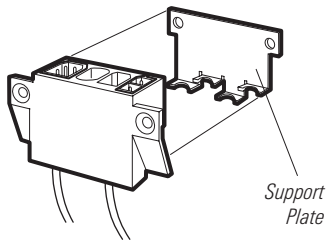

Attaching the Connector Holder to the Mounting Bracket

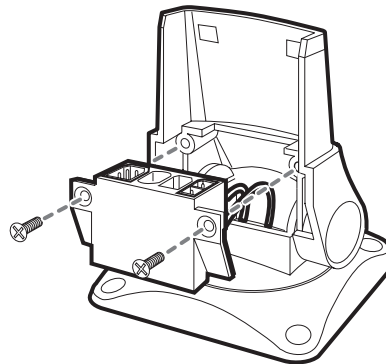

5. Install the control head by sliding it onto the mounting bracket until it is fully seated. To remove the unit, simply depress the latch on the rear of the unit and lift.
6. If the cables pass outside the mounting bracket, reinstall the hole cover over the thru-hole and fasten in place using the two #8 x 7/8" wood screws.

Your fishfinder is now ready for operation.

Cable Connector Holder

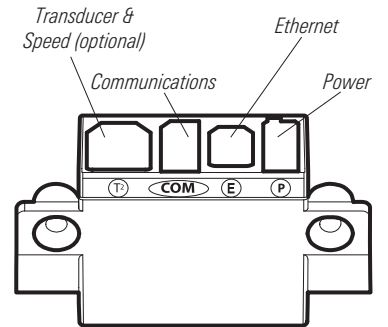

Inserting the Cable Connectors into the Connector Holder

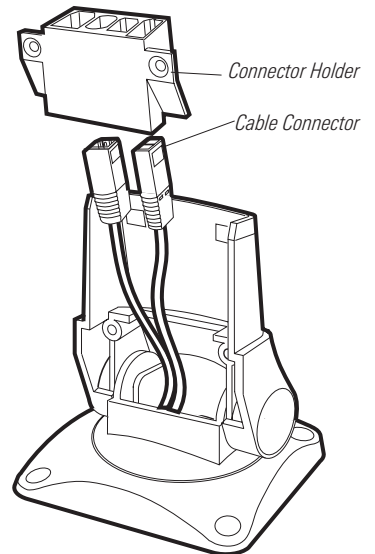

Removing the Unit from the Mount

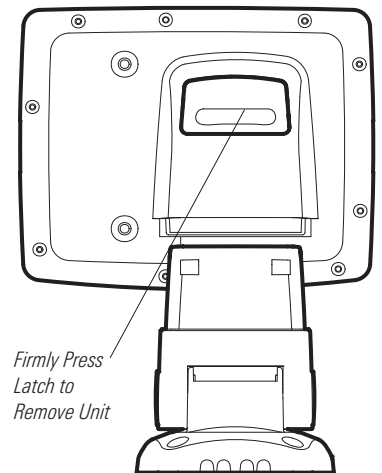

Quick Disconnect Mounting Bracket

531919-1_B

1-Year Limited Warranty

We warrant the original retail purchaser that products made by Humminbird® have been manufactured free from defects in materials and workmanship. This warranty is effective for one year from the date of original retail purchase. Humminbird® products found to be defective and covered by this warranty will be repaired or replaced free of charge at Humminbird's option and returned to the customer freight prepaid. Humminbird's sole responsibility under this warranty is limited to the repair or replacement of a product that has been deemed defective by Humminbird®. Humminbird® is not responsible for charges connected with the removal of such product or reinstallation of replaced or repaired parts.

This warranty does not apply to a product that has been:

- Improperly installed;
- Used in an installation other than that recommended in the product installation and operation instructions;
- Damaged or has failed because of an accident or abnormal operation;
- Repaired or modified by entities other than Humminbird®.

Please retain your original receipt as a proof of the purchase date. This will be required for in-warranty service.

THIS WARRANTY IS EXPRESSLY IN LIEU OF ANY OTHER WARRANTIES, OBLIGATIONS OR LIABILITIES ON THE PART OF HUMMINBIRD® AND WILL BE THE CUSTOMER'S EXCLUSIVE REMEDY, EXCEPT FOR ANY APPLICABLE IMPLIED WARRANTIES UNDER STATE LAW WHICH ARE HEREBY LIMITED IN DURATION TO ONE YEAR FROM THE DATE OF ORIGINAL PURCHASE. IN NO EVENT WILL HUMMINBIRD® BE LIABLE FOR ANY INCIDENTAL OR CONSEQUENTIAL DAMAGES FOR BREACH OF ANY EXPRESS OR IMPLIED WARRANTY RELATING TO THE PRODUCTS.

Some states do not allow limitations on an implied warranty, or the exclusion of incidental or consequential damages, so the above exclusions may not apply to you. You may also have other rights, which vary from state to state.

DOMESTIC (USA) CUSTOMERS:

PLEASE DO NOT RETURN THIS PRODUCT TO STORE FOR SERVICE

For all technical issues please call **1-800-633-1468**
or visit www.humminbird.com, click **SUPPORT**.

Please reference product serial number and model number when contacting Humminbird®.

Contact Humminbird®

Contact the Humminbird® Customer Resource Center
in any of the following ways:

By Telephone

(Monday - Friday 8:00 a.m. to 4:30 p.m. Central Standard Time):

1-800-633-1468

By e-mail

(typically we respond to your e-mail within three business days):

service@humminbird.com

For direct shipping, our address is:

**Humminbird®
Service Department
678 Humminbird Lane
Eufaula, AL 36027 USA**

ENVIRONMENTAL COMPLIANCE STATEMENT: *It is the intention of Johnson Outdoors Marine Electronics, Inc. to be a responsible corporate citizen, operating in compliance with known and applicable environmental regulations, and a good neighbor in the communities where we make or sell our products.*

WEEE DIRECTIVE: *EU Directive 2002/96/EC "Waste of Electrical and Electronic Equipment Directive (WEEE)" impacts most distributors, sellers, and manufacturers of consumer electronics in the European Union. The WEEE Directive requires the producer of consumer electronics to take responsibility for the management of waste from their products to achieve environmentally responsible disposal during the product life cycle.*

WEEE compliance may not be required in your location for electrical & electronic equipment (EEE), nor may it be required for EEE designed and intended as fixed or temporary installation in transportation vehicles such as automobiles, aircraft, and boats. In some European Union member states, these vehicles are considered outside of the scope of the Directive, and EEE for those applications can be considered excluded from the WEEE Directive requirement.



This symbol (WEEE wheeled bin) on product indicates the product must not be disposed of with other household refuse. It must be disposed of and collected for recycling and recovery of waste EEE. Johnson Outdoors Marine Electronics, Inc. will mark all EEE products in accordance with the WEEE Directive. It is our goal to comply in the collection, treatment, recovery, and environmentally sound disposal of those products; however, these requirements do vary within European Union member states. For more information about where you should dispose of your waste equipment for recycling and recovery and/or your European Union member state requirements, please contact your dealer or distributor from which your product was purchased.