



MINN KOTA
POWERDRIVE

POWERDRIVE

BOW-MOUNT TROLLING MOTOR

Owner's Manual

INTRODUCTION

THANK YOU

Thank you for choosing Minn Kota. We believe that you should spend more time fishing and less time positioning your boat. That's why we build the smartest, toughest, most intuitive trolling motors on the water. Every aspect of a Minn Kota trolling motor is thought out and rethought until it's good enough to bear our name. Countless hours of research and testing provide you the Minn Kota advantage that can truly take you "Anywhere. Anytime." We don't believe in shortcuts. We are Minn Kota. And we are never done helping you catch more fish.

REGISTRATION

Remember to keep your receipt and immediately register your trolling motor on our website at minnkota.johnsonoutdoors.com/register.

SERIAL NUMBER

Your Minn Kota 11-character serial number is very important. It helps to determine the specific model and year of manufacture. When contacting consumer service or registering your product you will need to know your product's serial number. A duplicate copy of your serial number label has been included which can also be entered in the One-Boat Network App for future reference.

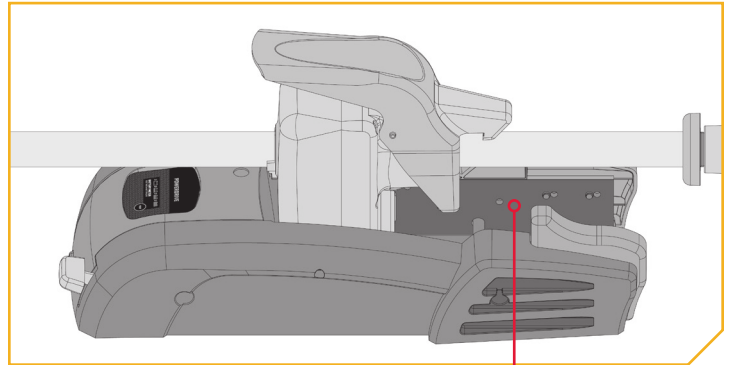

NOTICE: The serial number on your PowerDrive is located inside the mount below the motor rests.

MOTOR INFORMATION (For Consumer Reference Only)

Model Serial Number: _____

Controller Serial Number: _____

Purchase Date: _____

Store Where Purchased: _____

NOTICE: Do not return your Minn Kota motor to your retailer. Your retailer is not authorized to repair or replace this unit. You may obtain service by: calling Minn Kota at (800) 227-6433; returning your motor to the Minn Kota Factory Service Center; sending or taking your motor to any Minn Kota authorized service center. A list of authorized service centers is available on our website, at minnkota.johnsonoutdoors.com. Please include proof of purchase, serial number and purchase date for warranty service with any of the above options.

Made for iPhone® 11 and iPhone X

For updated iOS, Humminbird® and Minn Kota® compatibility, visit minnkota.johnsonoutdoors.com



Use of the Made for Apple badge means that an accessory has been designed to connect specifically to the Apple product(s) identified in the badge, and has been certified by the developer to meet Apple performance standards. Apple is not responsible for the operation of this device or its compliance with safety and regulatory standards. iPhone is a trademark of Apple Inc., registered in the U.S. and other countries. The trademark "iPhone" is used in Japan with a license from Aiphone K.K.

Android™ is a trademark of Google LLC. The Android robot is reproduced or modified from work created and shared by Google and used according to terms described in the Creative Commons 3.0 Attribution License.

TABLE OF CONTENTS

SAFETY CONSIDERATIONS	4
WARRANTY	6
KNOW YOUR BOAT	7
FEATURES	8
INSTALLATION	9
Installing the PowerDrive.....	10
Installing the Foot Pedal.....	15
Installing the Prop.....	15
Identifying Trolling Motor Features and Their Associated Cables.....	17
Feature & Cable Identification.....	17
Identifying Connections.....	17
Feature & Cable Management.....	19
Dual Spectrum CHIRP.....	19
Advanced GPS Navigation.....	24
Securing Accessory Cables.....	29
BATTERY & WIRING INSTALLATION	32
Boat Rigging & Product Installation.....	32
Conductor Gauge and Circuit Breaker Sizing Table.....	32
Selecting the Correct Batteries.....	33
Additional Considerations.....	33
Connecting the Batteries.....	34
Connecting the Batteries in Series.....	35
MOTOR WIRING DIAGRAM	36
USING & ADJUSTING THE MOTOR	38
Powering Up the Trolling Motor.....	38
Mount Features.....	38
Stowing and Deploying the Motor.....	39
Adjusting the Depth of the Motor.....	40
Adjusting the Latch Collar.....	41
Installing an External Transducer.....	42
Adjusting the Lower Unit for a Secure Stow.....	43
USING THE FOOT PEDAL	44
Controlling Speed & Steering with the Foot Pedal.....	44
SERVICE & MAINTENANCE	46
Propeller Replacement.....	46
General Maintenance.....	47
Troubleshooting.....	47
For Further Troubleshooting & Repair.....	48
COMPLIANCE STATEMENTS	49
PARTS DIAGRAM & PARTS LIST	51

SAFETY CONSIDERATIONS

Please thoroughly read the user manual. Follow all instructions and heed all safety and cautionary notices. Use of this motor is only permitted for persons that have read and understood these user instructions. Minors may use this motor only under adult supervision.

WARNING

You are responsible for the safe and prudent operation of your vessel. We have designed your Minn Kota product to be an accurate and reliable tool that will enhance boat operation and improve your ability to catch fish. This product does not relieve you from the responsibility for safe operation of your boat. You must avoid hazards to navigation and always maintain a permanent watch so you can respond to situations as they develop. You must always be prepared to regain manual control of your boat. Learn to operate your Minn Kota product in an area free from hazards and obstacles.

WARNING

Never run the motor out of the water, as this may result in injuries from the rotating propeller. The motor should be disconnected from the power source when it is not in use or is off the water. When connecting the power-supply cables of the motor to the battery, ensure that they are not kinked or subject to chafe and route them in such a way that persons cannot trip over them. Before using the motor make sure that the insulation of the power cables is not damaged. Disregarding these safety precautions may result in electric shorts of battery(s) and/or motor. Always disconnect motor from battery(s) before cleaning or checking the propeller. Avoid submerging the complete motor as water may enter the lower unit through control head and shaft. If the motor is used while water is present in the lower unit considerable damage to the motor can occur. This damage will not be covered by warranty.

WARNING

Take care that neither you nor other persons approach the turning propeller too closely, neither with body parts nor with objects. The motor is powerful and may endanger or injure you or others. While the motor is running watch out for persons swimming and for floating objects. Persons whose ability to run the motor or whose reactions are impaired by alcohol, drugs, medication, or other substances are not permitted to use this motor. This motor is not suitable for use in strong currents. The constant noise pressure level of the motor during use is less than 70dB(A). The overall vibration level does not exceed 2,5 m/sec².

WARNING

When stowing or deploying the motor, keep fingers clear of all hinge and pivot points and all moving parts. In the event of unexpected operation, remove power leads from the battery.

WARNING

It is recommended to only use Johnson Outdoors approved accessories with your Minn Kota motor. Using non-approved accessories including to mount or control your motor may cause damage, unexpected motor operation and injury. Be sure to use the product and approved accessories, including remotes, safely and in the manner directed to avoid accidental or unexpected motor operation. Keep all factory installed parts in place including motor and accessory covers, enclosures and guards.



WARNING

- **INGESTION HAZARD:** This product contains a button cell or coin battery.
- **DEATH** or serious injury can occur if ingested.
- A swallowed button cell or coin battery can cause **Internal Chemical Burns** in as little as **2 hours**.
- **KEEP** new and used batteries **OUT OF REACH** of **CHILDREN**
- **Seek immediate medical attention** if a battery is suspected to be swallowed or inserted inside any part of the body.



1. This product contains a button/coin cell battery. Heed all safety considerations:
 - a) Remove and immediately recycle or dispose of used batteries according to local regulations and keep away from children. Do NOT dispose of batteries in household trash or incinerate.
 - b) Even used batteries may cause severe injury or death.
 - c) Call a local poison control center for treatment information.
 - d) The compatible battery type is CR2450.
 - e) The nominal battery voltage is 3.0 VDC.
 - f) Non-rechargeable batteries are not to be recharged.
 - g) Do not force discharge, recharge, disassemble, heat above (manufacturer's specified temperature rating) or incinerate. Doing so may result in injury due to venting, leakage or explosion resulting in chemical burns.
2. This product contains a replaceable button/coin cell battery. Heed all safety considerations:
 - a) Ensure the batteries are installed correctly according to polarity (+ and -).
 - b) Do not mix old and new batteries, different brands or types of batteries, such as alkaline, carbon-zinc, or rechargeable batteries.
 - c) Remove and immediately recycle or dispose of batteries from equipment not used for an extended period of time according to local regulations.
 - d) Always completely secure the battery compartment. If the battery compartment does not close securely, stop using the product, remove the batteries, and keep them away from children.

WARRANTY

WARRANTY ON MINN KOTA FRESHWATER TROLLING MOTORS

Minn Kota Freshwater Trolling Motors - Limited Lifetime Warranty On Composite Shaft And Limited Two-Year Warranty On The Entire Product

Johnson Outdoors Marine Electronics, Inc. ("JOME") extends the following limited warranty to the original retail purchaser only. Warranty coverage is not transferable.

Minn Kota Limited Two-Year Warranty on the Entire Product

JOME warrants to the original retail purchaser only that the purchaser's new Minn Kota freshwater trolling motor will be materially free from defects in materials and workmanship appearing within two (2) years after the date of purchase. JOME will (at its option) either repair or replace, free of charge, any parts found by JOME to be defective during the term of this warranty. Such repair, or replacement shall be the sole and exclusive liability of JOME and the sole and exclusive remedy of the purchaser for breach of this warranty.

Minn Kota Limited Lifetime Warranty on the Composite Shaft

JOME warrants to the original retail purchaser only that the composite shaft of the purchaser's Minn Kota trolling motor will be materially free from defects in materials and workmanship appearing within the original purchaser's lifetime. JOME will provide a new composite shaft, free of charge, to replace any composite shaft found by JOME to be defective during the term of this warranty. Providing a new composite shaft shall be the sole and exclusive liability of JOME and the sole and exclusive remedy of the purchaser for breach of this warranty; and purchaser shall be responsible for installing, or for the cost of labor to install, any new composite shaft provided by JOME.

EXCLUSIONS AND LIMITATIONS

This limited warranty does not apply to products that have been used in saltwater or brackish water, commercially or for rental purposes. This limited warranty does not cover normal wear and tear, blemishes that do not affect the operation of the product, or damage caused by accidents, abuse, alteration, modification, shipping damages, acts of God, negligence of the user or misuse, improper or insufficient care or maintenance. DAMAGE CAUSED BY THE USE OF OTHER REPLACEMENT PARTS NOT MEETING THE DESIGN SPECIFICATIONS OF THE ORIGINAL PARTS WILL NOT BE COVERED BY THIS LIMITED WARRANTY. The cost of normal maintenance or replacement parts which are not in breach of the limited warranty are the responsibility of the purchaser. Prior to using products, the purchaser shall determine the suitability of the products for the intended use and assumes all related risk and liability. Any assistance JOME provides to or procures for the purchaser outside the terms, limitations or exclusions of this limited warranty will not constitute a waiver of the terms, limitations or exclusions, nor will such assistance extend or revive the warranty. JOME will not reimburse the purchaser for any expenses incurred by the purchaser in repairing, correcting or replacing any defective products or parts, except those incurred with JOME's prior written permission. JOME'S AGGREGATE LIABILITY WITH RESPECT TO COVERED PRODUCTS IS LIMITED TO AN AMOUNT EQUAL TO THE PURCHASER'S ORIGINAL PURCHASE PRICE PAID FOR SUCH PRODUCT.

Minn Kota Service Information

To obtain warranty service in the U.S., the product believed to be defective, and proof of original purchase (including the date of purchase), must be presented to a Minn Kota Authorized Service Center. Go to minnkota.johnsonoutdoors.com/us/support/service-providers/locate to find a Minn Kota Authorized Service Center. Any charges incurred for service calls, transportation or shipping/freight to/from the Minn Kota Authorized Service Center, labor to haul out, remove, re-install or re-rig products removed for warranty service, or any other similar items are the sole and exclusive responsibility of the purchaser. Products purchased outside of the U.S. must be returned prepaid with proof of purchase (including the date of purchase and serial number) to any Authorized Minn Kota Service Center in the country of purchase. To contact Minn Kota Customer Service go to minnkota-help.johnsonoutdoors.com/hc. Products repaired or replaced will be warranted for the remainder of the original warranty period, or for 90 days from the date of repair or replacement, whichever is longer. For any product that is returned for warranty service that JOME finds to be not covered by or not in breach of this limited warranty, there will be a billing for services rendered at the prevailing labor rate of the applicable Minn Kota Authorized Service Center and for a minimum of at least one hour.

Service Provider Locator



Contact Customer Service



NOTICE: Do not return your Minn Kota product to your retailer. Your retailer is not authorized to repair or replace products.

NOTICE: THERE ARE NO EXPRESS WARRANTIES OTHER THAN THESE LIMITED WARRANTIES. IN NO EVENT SHALL ANY IMPLIED WARRANTIES INCLUDING ANY IMPLIED WARRANTIES OF MERCHANTABILITY OR FITNESS FOR PARTICULAR PURPOSE, EXTEND BEYOND THE DURATION OF THE RELEVANT EXPRESS LIMITED WARRANTY. IN NO EVENT SHALL JOME BE LIABLE FOR PUNITIVE, INDIRECT, INCIDENTAL, CONSEQUENTIAL OR SPECIAL DAMAGES. Without limiting the foregoing, JOME assumes no responsibility for loss of use of product, loss of time, inconvenience or other damage.

Some states do not allow limitations on how long an implied warranty lasts or the exclusion or limitation of incidental or consequential damages, so the above limitations and/or exclusions may not apply to you. This warranty gives you specific legal rights and you may also have other legal rights which vary from state to state.

KNOW YOUR BOAT

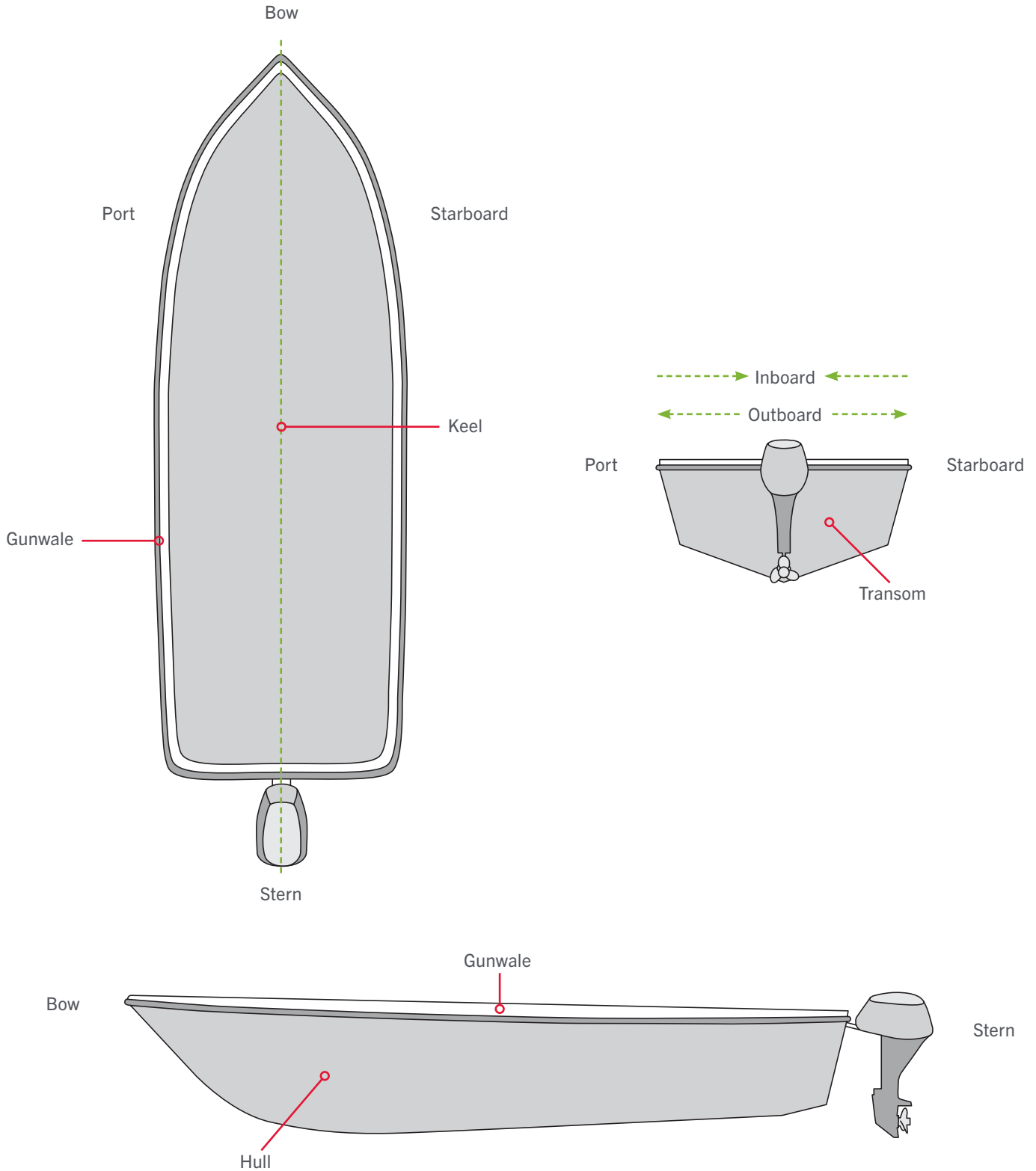

FEATURES

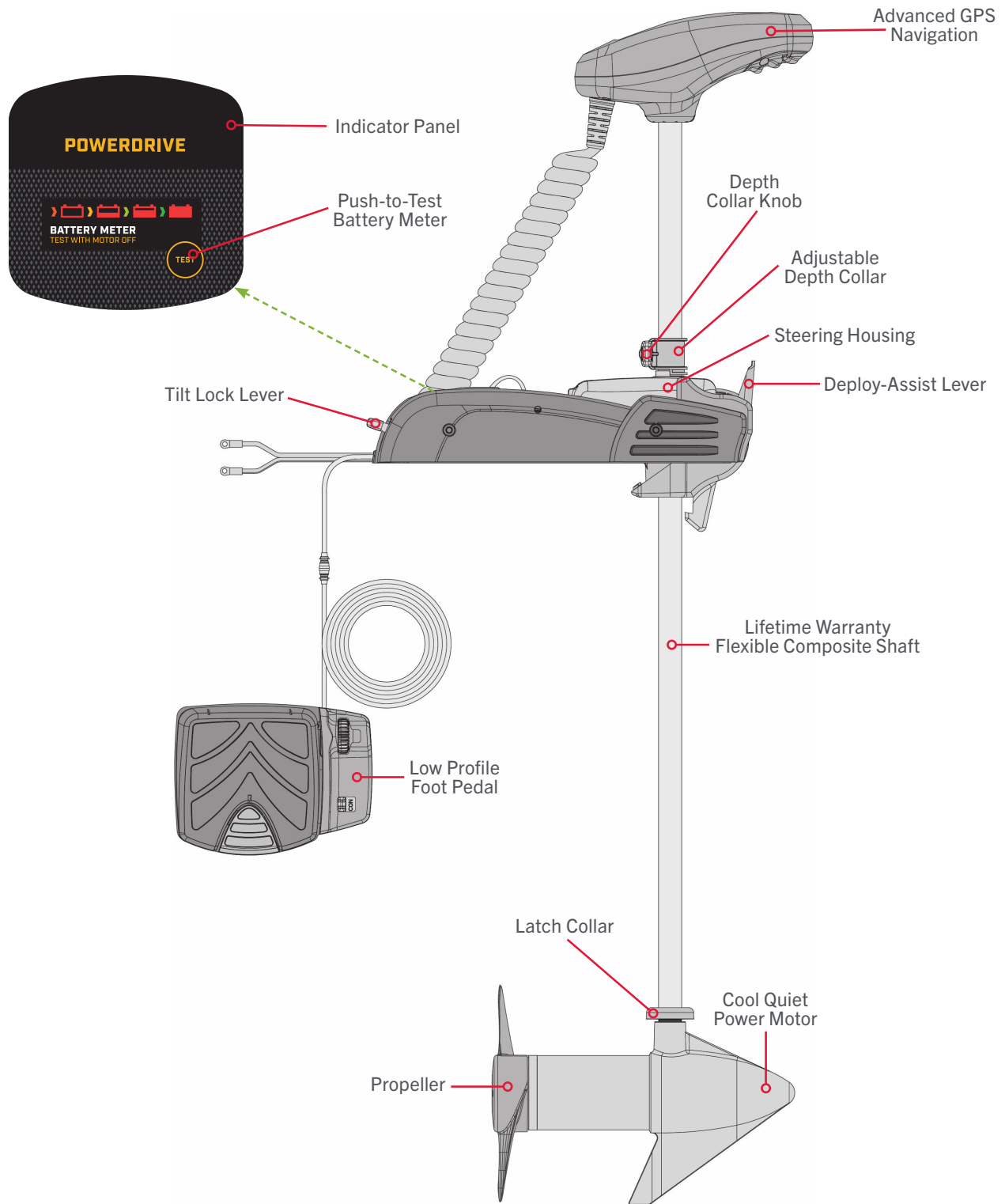

NOTICE: Specifications subject to change without notice. This diagram is for reference only and may differ from your actual motor.

INSTALLATION

INSTALLING THE POWERDRIVE

Your new PowerDrive comes with everything you'll need to directly install it to the boat. This motor can be directly mounted to the boat or coupled with a Minn Kota quick release bracket for ease of mounting and removal. For installation with a quick release bracket, refer to the installation instructions provided with the bracket. For compatible quick release mounting brackets and to locate your nearest dealer, visit minnkota.johnsonoutdoors.com. To install the motor directly to the boat, please follow the instructions provided in this manual. Please review the parts list, mounting considerations and tools needed for installation prior to getting started. For additional product support, please visit minnkota.johnsonoutdoors.com.

INSTALLATION PARTS LIST

Item / Assembly	Part #	Description	Qty.
A Includes 1 - 4	2994864	BAG ASSEMBLY - (BOLT, NUT, WASHERS)	1
1	2263462	BOLT-MOUNTING-1/4X2 W/STG	6
2	2261713	WASHER-1/4	6
3	2263103	NUT NYLOK 1/4-20 MTG	6
4	2301720	WASHER-MOUNTING RUBBER	6
U Includes 5 - 8	1378170	PROP KIT 2091170 PWR PRP	1
V Includes 5 - 8	1378121	PROP IND 2061122 (PWR PROP)	1
5	2061122	PROP-POWER (3.25")	1
	2091170	PROP-WW2 (3 5/8") REAMED SUB)	1
6	2151726	WASHER-5/16 SS	1
7	2053101	NUT-PROP NYLOC	1
8	2092600	PIN-DRIVE 1.06" LG SS	1
Z Includes 9	2994859	BAG ASY-TERROVA/V2,RUB.BUMPERS	1
9	2325110	PAD, FOOT PEDAL PD	5
10	2994728	FOOT PEDAL ASSEMBLY, PD	1
11	✳	MOTOR ASSEMBLY	1
12	2390802 ◆	LANYARD W/CARABINR, IP RMT	1
13	2994175 ◆	REMOTE ASM, MICRO REMOTE	1
14	2394110 ◆	TAG, MICRO REMOTE	1
15	490384-4 ◆	CABLE, ETHERNET (M12-M12) 30'	1
16	490380-1 ◆	CABLE, ETHERNET PIGTAIL-700 HD	1
▲	23949112 ◆	QCK REF.GUIDE, iP MICRO RMT BT	1
▲	2317126	INSTRC-INSTALL, POWERDRIVE FW	1
▲	2297165	MANUAL-DISCLAIMER,DWNLOAD INFO	1
D Includes 17	2996300	TIE WRAP ASM, 60"	1
17	2206300	TIE WRAP, LOW PROFILE 4"	10
▲	2294950	OBN & REMOTE PAIR INSTRUCT	1
18	2994961 ●	BAG ASM, CABLE ADPT, 490537-2 *490537-2* *MKR-MI-1*	1
▲	2207131	STANDARD QS SETUP GUIDE	1

▲ Not shown on Parts Diagram.

✳ This part is included in an assembly and cannot be ordered individually.

◆ Only available with models factory installed with GPS.

● Only available with models factory installed with Dual Spectrum CHIRP

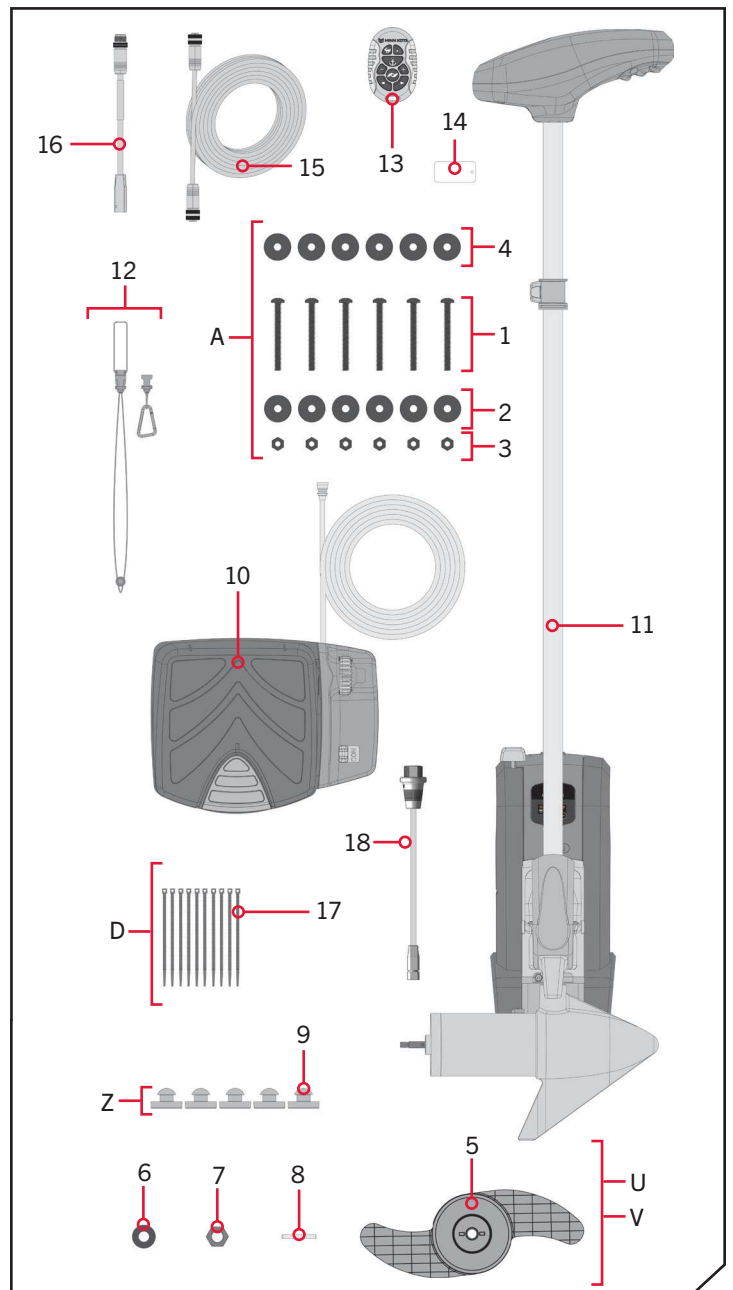

INSTALLING THE POWERDRIVE

MOUNTING CONSIDERATIONS

It is recommended that the motor be mounted as close to the centerline of the boat as possible. Make sure the area under the mounting location is clear to drill holes and install nuts and washers. Make sure the motor rest is positioned far enough beyond the edge of the boat. The motor must not encounter any obstructions as it is lowered into the water or raised into the boat when stowed and deployed. Consider a quick release or adapter bracket with the installation of your motor. To view a list of accessories, please visit minnkota.johnsonoutdoors.com.



View accessories available for your trolling motor at minnkota.johnsonoutdoors.com.

TOOLS AND RESOURCES REQUIRED

- #3 and #2 Phillips Screw Driver
- Drill
- 9/32" Drill Bit
- 7/16" Box End Wrench
- A second person to help with the installation
- Pliers or Vice Grip

INSTALLATION

INSTALLING THE POWERDRIVE

1. a. Make sure that the Power Cables from the battery are disconnected, or that the breaker, if equipped, is "off".

WARNING

Make sure the motor is mounted on a level surface and is not connected to a power source.

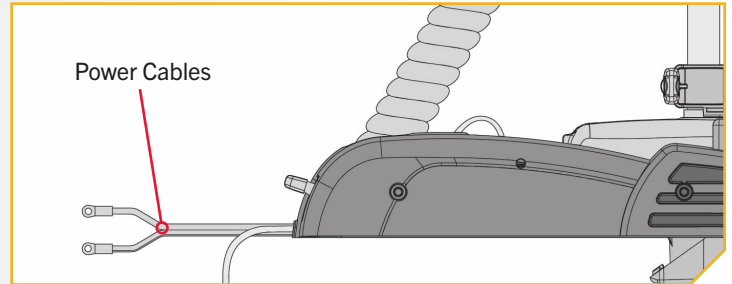

NOTICE: The PowerDrive has no power switch. When the Power Cables are connected to a battery, the PowerDrive is "on". When the Power Cables are disconnected from the battery, the PowerDrive is "off". If the Power Cables are connected to a breaker, the PowerDrive is "on" when the breaker is "on" and "off" when the breaker is "off".

INSTALLING THE POWERDRIVE

2

- b. Place the mount on an elevated, level surface such as a workbench or the tailgate of a pickup. The motor, as removed from the box, should be in the stowed position.
- c. Remove the four sideplate screws using a #3 or #2 Phillips screwdriver. Two of these screws will be located on each side of the mount.

NOTICE: This motor weighs approximately 30 lbs. We recommend having a second person help with the installation.

2b

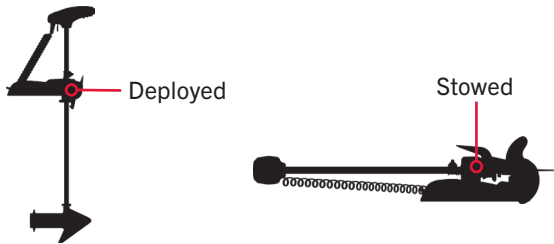

2c

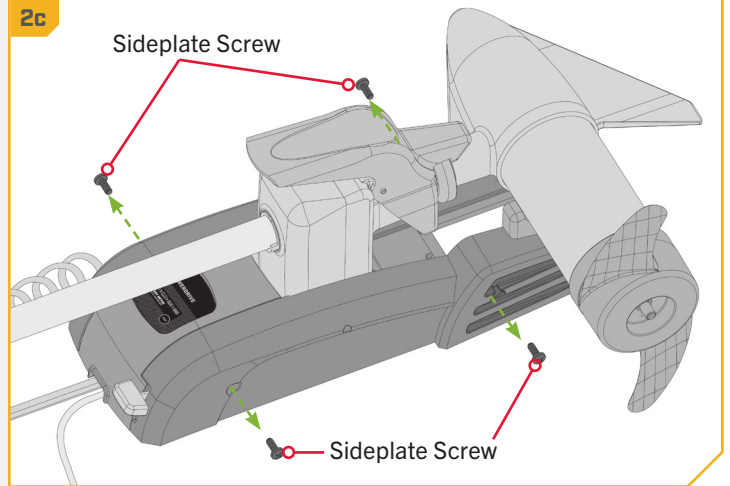

3

- d. Remove the Right Sideplate.
- e. Swing the Left Sideplate out and away from the Base Extrusion.

3d

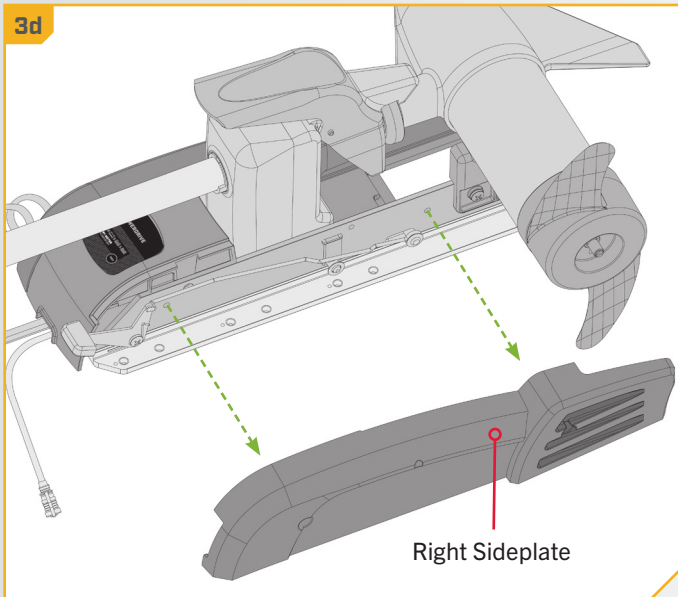

3e

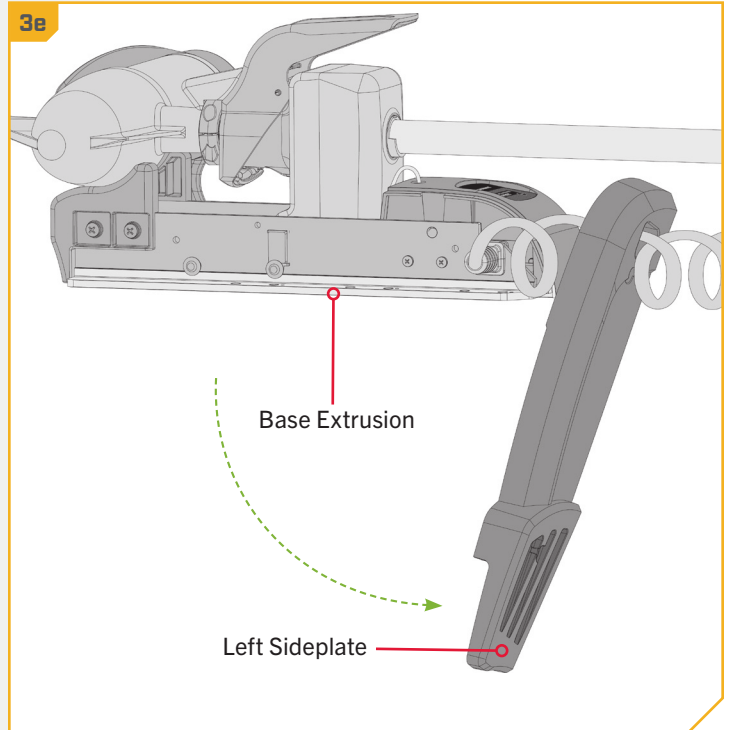

INSTALLING THE POWERDRIVE

4

- f. Place the mount as close to the centerline or keel of the boat as possible. The motor can be installed on either the Port or Starboard side of the boat based on personal preference. Check placement with the motor in the stowed and deployed positions. Review the mounting considerations at the beginning of the installation.

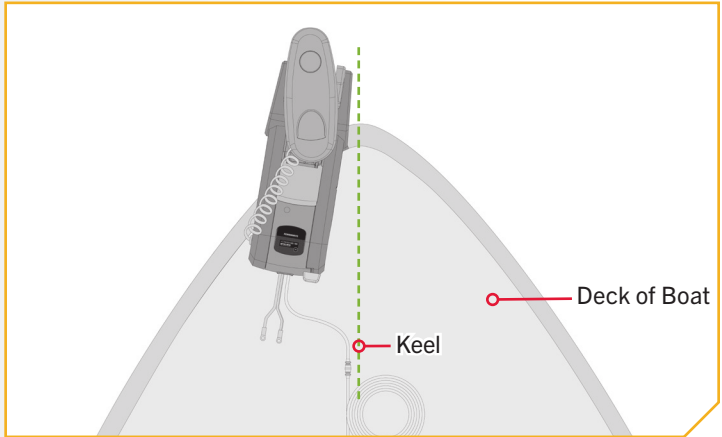

5

ITEM(S) NEEDED

- #4 x 6

- g. When the motor is in the deployed position, make sure that the Shaft is 1-1/2" out past the Gunwale of the boat. The lower unit, when stowed and deployed must not encounter any obstructions.
- h. Check to be sure that the mount is level. Use the Rubber Washers (Item #4) provided to create a level surface if necessary.

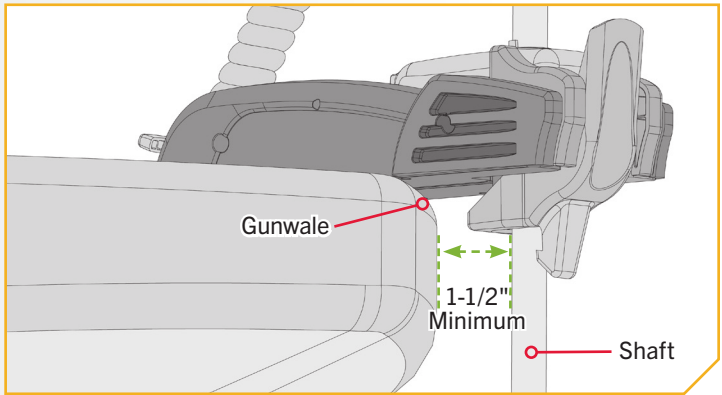

6

- i. It is recommended to mark at least 6 of the 12 holes in the Base Extrusion and to have a minimum of two bolts on each side that are located the farthest apart. Ideal installation would allow for 6 bolts to be used, with a minimum of 4.
- j. Drill through the deck of the boat using a 9/32" Drill Bit on the marked locations.

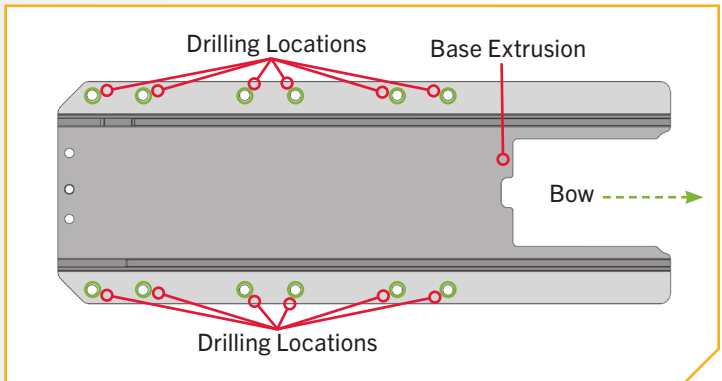

7

ITEM(S) NEEDED

● #4 x 6

| #1 x 6

- k. Put a 1/4-20 x 3-1/2" (Item #1) Screw in each of the drilled locations. The Screw should pass through the Base Extrusion and the boat deck. If the Rubber Washers (Item #4) are used, they should sit between the Base Extrusion and boat deck. Make sure to secure the motor with screws on each side of the Base Extrusion.

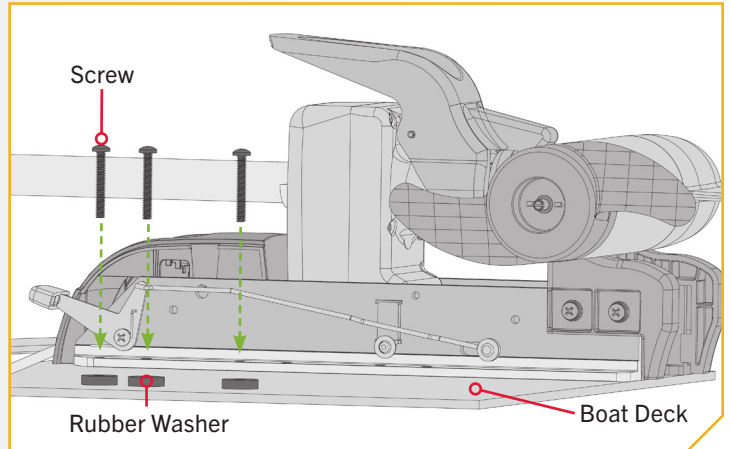

8

ITEM(S) NEEDED

● #2 x 6

○ #3 x 6

- i. Place a Flat Washer (Item #2) and then a Nylock Nut (Item #3) at the end of each screw as shown and secure. Make sure all hardware is secure.

NOTICE: To prevent seizing of the stainless steel hardware, do not use high speed installation tools. Wetting the screws or applying an anti-seize may help prevent seizing.

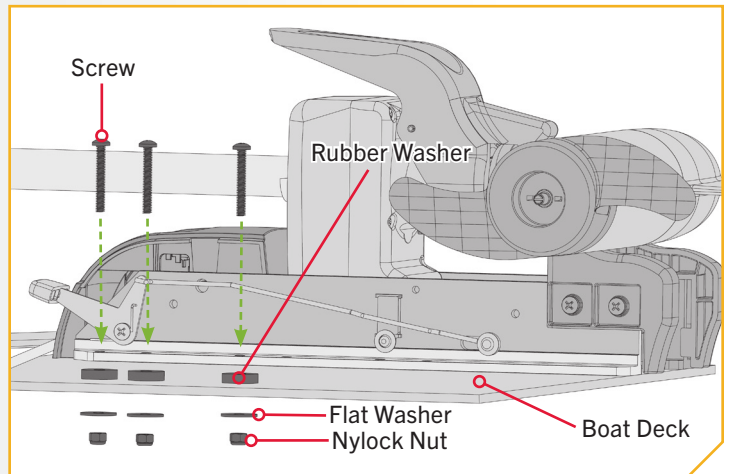

INSTALLING THE POWERDRIVE

9

- m. Replace the Right Sideplate.
- n. Swing the Left Sideplate back into its correct position on the Base Extrusion.

9m

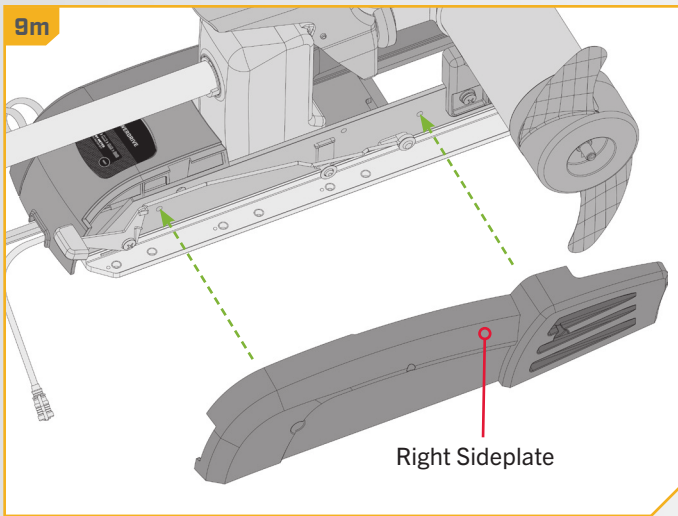

9n

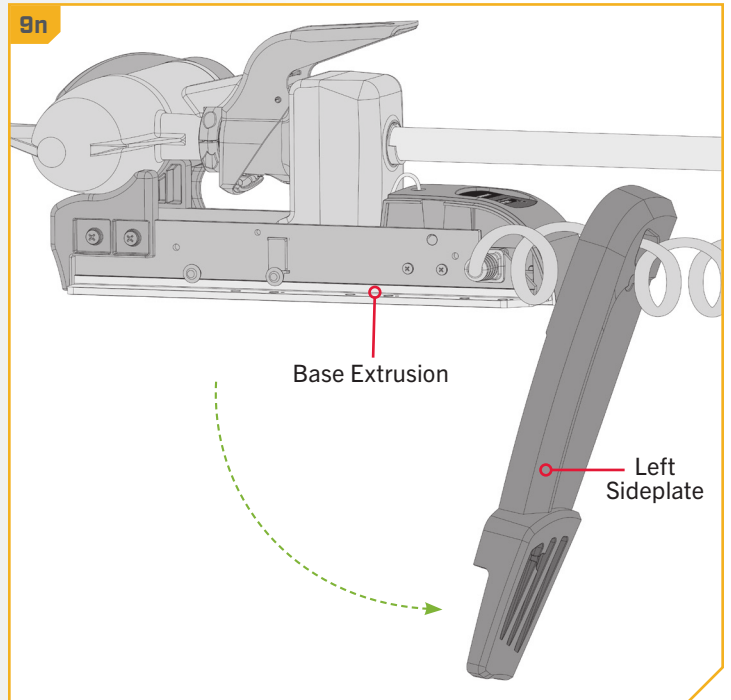

10

- o. Replace the four sideplate screws using a #3 or #2 Phillips screwdriver. Two of these screws will be located on each side of the mount.

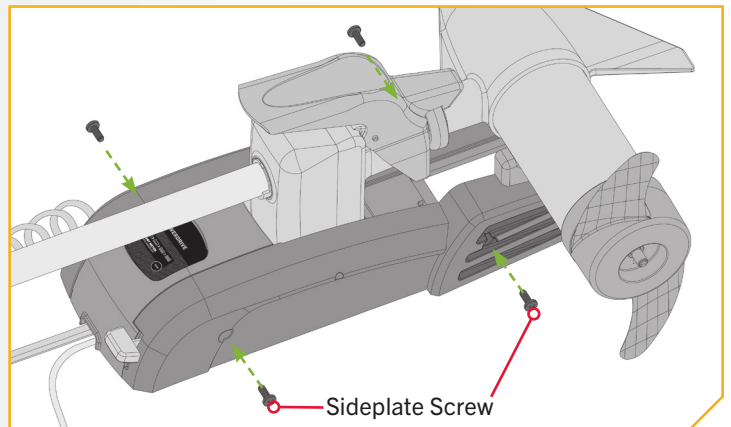

› Installing the Foot Pedal

1

ITEM(S) NEEDED

 #9 x 5



#10 x 1

- a. Take the Foot Pedal (Item #10) and turn it over. Put a Foot Pedal Pad (Item #9) in each of the pad locations.

NOTICE: The pads are recommended when using the Foot Pedal on non-carpeted surfaces.

- b. Locate the 7 pin Foot Pedal Connector on the Foot Pedal and the Power Connector from the Motor. Align the pins of the Foot Pedal Connector to the matching socket end of the Power Connector. Firmly push the Plug together.

NOTICE: The connectors are keyed to prevent reversed installation.

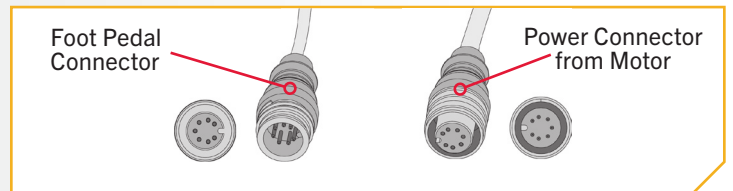
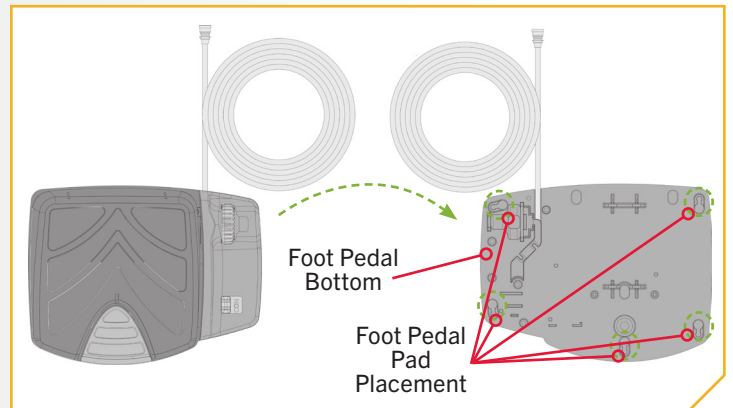

› Installing the Prop

1

CAUTION

Disconnect the motor from the battery before beginning any prop work or maintenance.

- a. While holding the Shipping Spacer with a pliers or vise grip, remove the Prop Nut, Red Shipping Washer, Prop Washer and Spacer, being careful not to lose the Drive Pin. Reuse the Prop Nut, Prop Washer and Drive Pin to attach the Propeller.

NOTICE: The Shipping Spacer and Red Shipping Washer are for shipping purposes only and must be discarded. The Red Shipping Washer will rust if used to attach the Propeller.

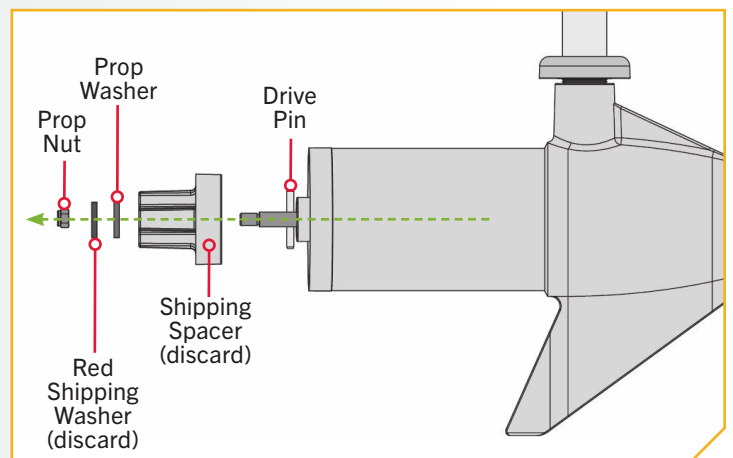

INSTALLING THE PROP

2

ITEM(S) NEEDED



- b. Take the Drive Pin (Item #8) and slide it through the Hole in the Armature Shaft. Position the Drive Pin horizontal by grasping the Armature Shaft and rotating it with the Drive Pin in place.
- c. Align the Propeller (Item #5) so it is also horizontal and parallel with the Drive Pin. Slide the Propeller onto the Armature Shaft and Drive Pin until it is seated against the lower unit.
- d. Install the Prop Washer (Item #6) and the Prop Nut (Item #7) onto the end of the Armature Shaft.

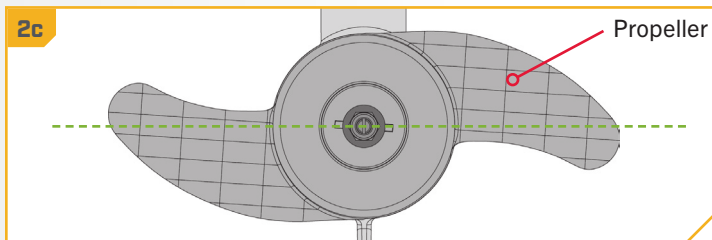
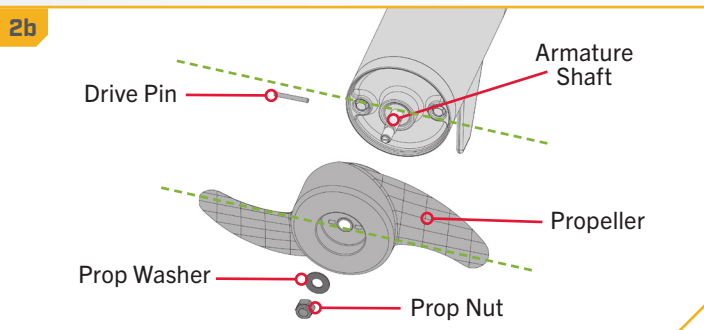

3

- e. Holding the end of the Armature Shaft with a Flat Blade Screwdriver, tighten the Prop Nut with a 9/16" Open End Wrench.
- f. Tighten the Prop Nut 1/4 turn past snug to 25-35 in-lbs.



CAUTION

Do not over tighten as this can damage the prop.

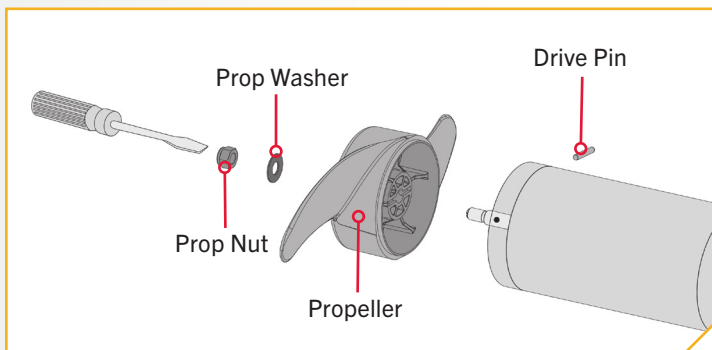

IDENTIFYING TROLLING MOTOR FEATURES AND THEIR ASSOCIATED CABLES

IDENTIFYING TROLLING MOTOR FEATURES AND THEIR ASSOCIATED CABLES

Feature & Cable Identification

The PowerDrive may be pre-installed with Dual Spectrum CHIRP sonar or Advanced GPS Navigation - including the ability to connect via Ethernet to a Humminbird fish finder. These features may be installed on their own or in combination with another feature. All of these features require Accessory Cables to be connected to an output device. The connectors are present on the trolling motor and have cables that exit below the Control Head or exit the Coil Cord at the base of the Mount. To better identify Accessory Cables present, refer to the diagrams that detail what the Dual Spectrum CHIRP and Advanced GPS Navigation connectors look like.

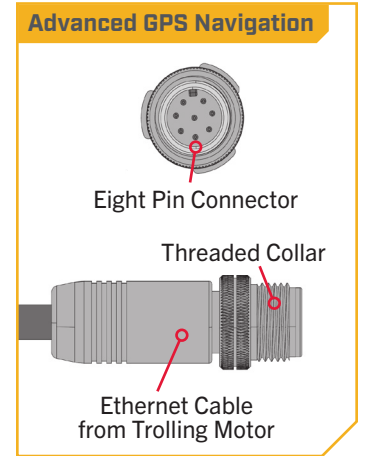
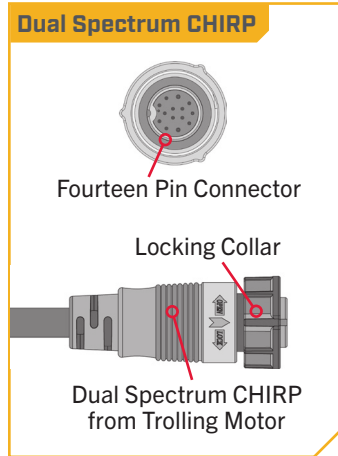

Identifying Connectors

If there are **NO** connectors below the Control Head, the trolling motor may be equipped with:

Foot Pedal - The Power Connector to the Foot Pedal will be present at the base of the Mount along with the Power Leads. The Power Connector is keyed and attaches to the Eight Pin Connector from the Foot Pedal.

If **ONE** connector is present below the Control Head the trolling motor is equipped with:

Dual Spectrum CHIRP - If Dual Spectrum CHIRP is pre-installed on your trolling motor, one Dual Spectrum CHIRP accessory cable will exit the base of the Control Head and run down the center of the Coil Cord. The end of the cable will have a Fourteen Pin Connector. Motors with Dual Spectrum CHIRP will also have a transducer in the Lower Unit. Motors with Dual Spectrum CHIRP will have a Power Connector for the Foot Pedal present at the base of the Mount along with the Power Leads.

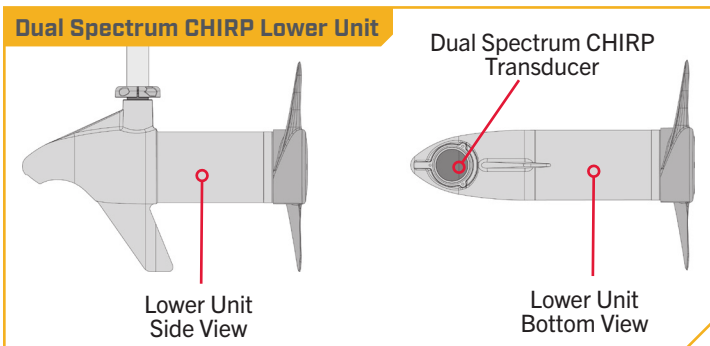
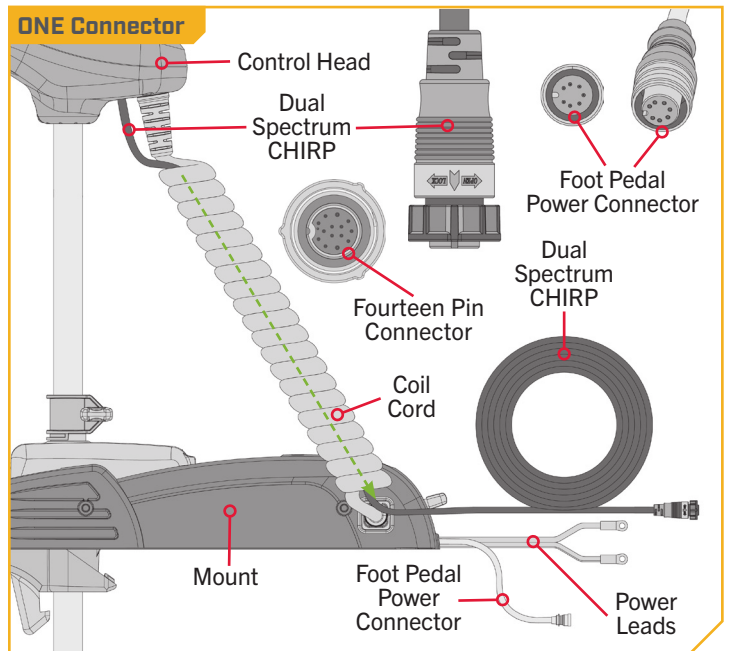
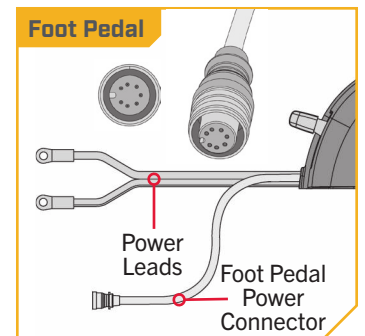
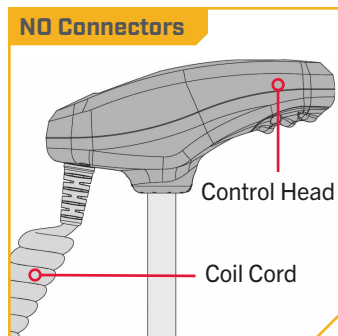

IDENTIFYING TROLLING MOTOR FEATURES AND THEIR ASSOCIATED CABLES

If **TWO** connectors are present below the Control Head the trolling motor will be equipped with:

Advanced GPS Navigation - If Advanced GPS Navigation is pre-installed on your trolling motor, one eight pin Advanced GPS Ethernet Connector will exit the base of the Control Head and rest just below the Control Head next to the Coil Cord and one Advanced GPS Cable will exit the base of the Control Head and run down the center of the Coil Cord. The Advanced GPS Cable will come to a "Y" near the Mount of the trolling motor. One half of the "Y" will enter the Mount next to the Power Leads and the main portion of the cable will be attached from the factory to the Foot Pedal Power Connector. If a trolling motor is equipped with Advanced GPS Navigation, it will not be equipped with a Foot Pedal. If the Advanced GPS Navigation on the trolling motor will be used with a fish finder, an Ethernet Cable may be attached to the Advanced GPS Ethernet Connector below the Control Head. See the "Advanced GPS Navigation" section of this document for details on how to install the Advanced GPS Ethernet Connector to a Humminbird.

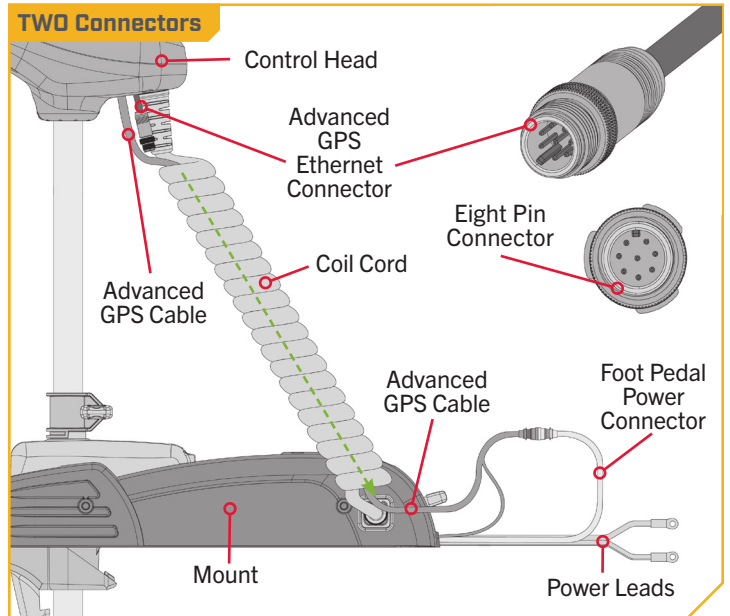

If **THREE** connectors are present below the Control Head the trolling motor will be equipped with:

Dual Spectrum CHIRP & Advanced GPS Navigation - If Dual Spectrum CHIRP is pre-installed on your trolling motor, one Dual Spectrum CHIRP accessory cable will exit the base of the Control Head and run down the center of the Coil Cord. The end of the Cable will have a Fourteen Pin Connector. Motors with Dual Spectrum CHIRP will also have a transducer in the Lower Unit.

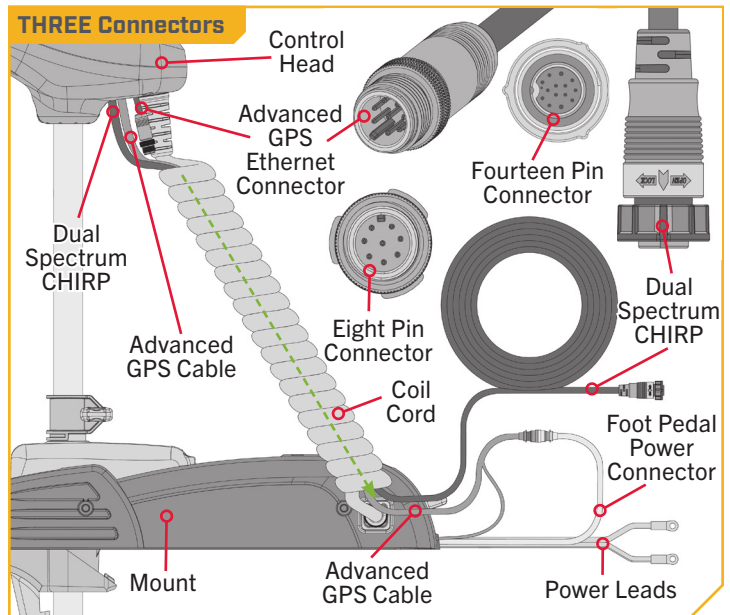

If Advanced GPS Navigation is pre-installed on your trolling motor, one Advanced GPS Ethernet Connector will exit the base of the Control Head and rest just below the Control Head next to the Coil Cord and one Advanced GPS Cable will exit the base of the Control Head and run down the center of the Coil Cord. The Advanced GPS Cable will come to a "Y" near the Mount of the trolling motor. One half of the "Y" will enter the Mount next to the Power Leads and the main portion of the cable will be attached from the factory to the Foot Pedal Power Connector. Motors with Advanced GPS Navigation and Dual Spectrum CHIRP will not have a Foot Pedal. If the Advanced GPS Navigation on the trolling motor will be used with a fish finder, an Ethernet Cable may be attached to the Advanced GPS Ethernet Connector below the Control Head. See the "Advanced GPS Navigation" section of this document for details on how to install the Advanced GPS Ethernet Connector to a Humminbird.

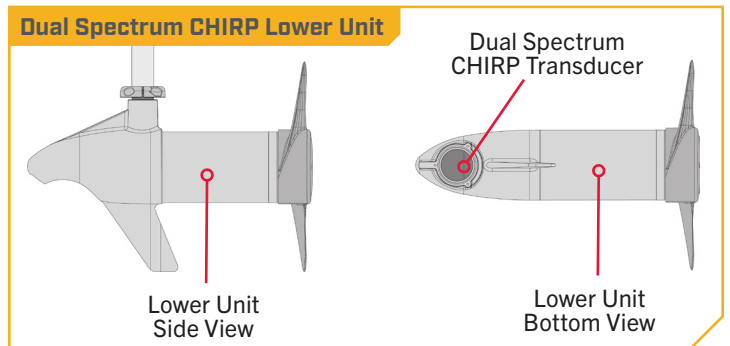

Feature & Cable Management

DUAL SPECTRUM CHIRP

Your trolling motor may be pre-installed with a transducer system featuring Humminbird's Dual Spectrum CHIRP. CHIRP stands for "Compressed High Intensity Radar Pulse". Dual Spectrum CHIRP is a 2D sonar transducer with a temperature sensor that is integrated into the lower unit of the trolling motor. Humminbird also utilizes a proprietary, best-in-class transducer designed and built to maximize fish detail, as well as coverage area. Dual Spectrum CHIRP scans the water for fish similar to the way the seek function on your truck's radio scans the airwaves for FM stations. By covering a wide range of frequencies, CHIRP produces more accurate, more detailed returns of fish, structure, and the bottom.

Humminbird's Dual Spectrum CHIRP gives you full spectrum capability, plus the power to select your own start and end frequencies by operating in two different modes. Wide Mode for maximum coverage and Narrow Mode for maximum detail. Wide mode allows you to search deep and wide. Is it used for watching your lure while vertical jigging, or gaining a more expansive view in shallow water. Narrow Mode is used to hone in on the small stuff that makes a big difference. Narrow Mode provides a precise perspective of the water below, helping you target individual fish, or identify fish hidden in structure and/or tight to the bottom.

Dual Spectrum CHIRP features:

SUPERIOR TARGET SEPARATION - Separating fish from their habitat is the name of the game. And now, you'll be able to tell the difference more easily between bait and game fish, and nearby structure and vegetation.

CLEARLY DEFINED FISH ARCHES - We've got bad news for your arch nemesis. Large game fish will show up on your screen as long, well-defined arches, for quick identification and accurate lure presentation.

STRONG RETURNS WITHOUT NOISE - Stop seeing things that aren't there. A high signal-to-noise ratio translates to better defined targets, less clutter and greater certainty that what you're looking at on-screen is legit.

Dual Spectrum CHIRP Lower Unit

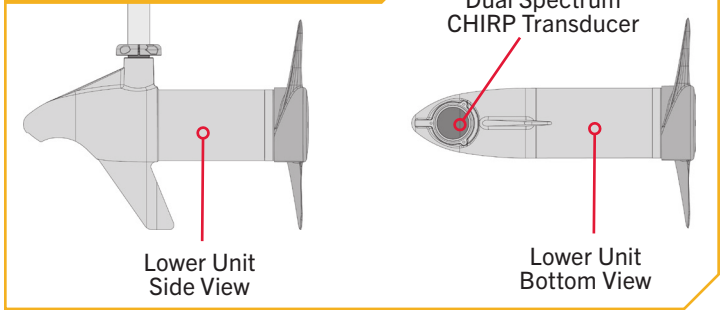

Wide Mode

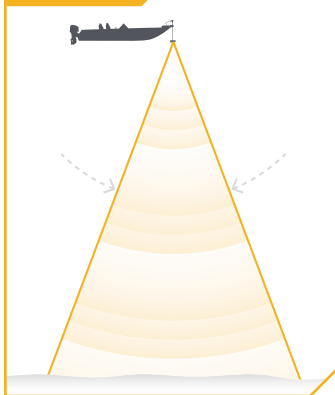

Narrow Mode

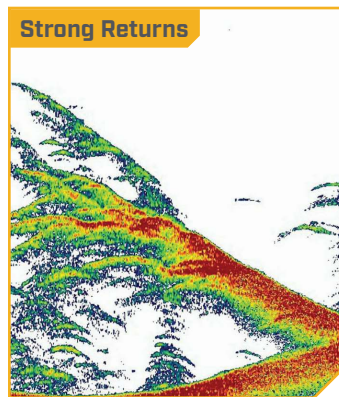
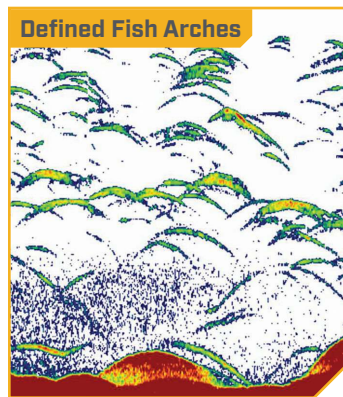
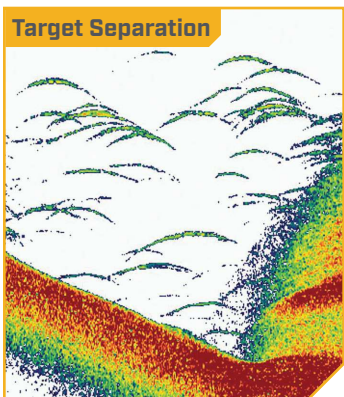
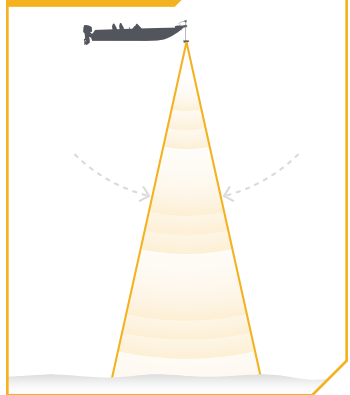

DUAL SPECTRUM CHIRP

The integrated design of the Dual Spectrum CHIRP transducer protects it in the lower unit of the trolling motor from underwater hazards and prevents tangles and damage to the transducer cables. In certain situations, air bubbles may adhere to the surface of the Dual Spectrum CHIRP transducer and affect the performance. If this happens, simply wipe the surface of the transducer with your finger.

› Considerations for Connecting and Routing Dual Spectrum CHIRP

If Dual Spectrum CHIRP is pre-installed on your trolling motor, one Dual Spectrum CHIRP accessory cable will exit the base of the Control Head and run down the center of the Coil Cord. Dual Spectrum CHIRP requires cables to be connected to an output device such as a Humminbird® fish finder. The Dual Spectrum CHIRP cable that exits the Coil Cord is "Apex and Solix Ready". Connecting the trolling motor equipped with a Dual Spectrum CHIRP transducer to a compatible fish finder gives you a 2D sonar view of what is happening directly below your trolling motor. To determine if your fish finder is compatible with Dual Spectrum CHIRP, please visit minnkota.johnsonoutdoors.com to check compatibility. The Dual Spectrum CHIRP cable from the trolling motor may be plugged directly into a Solix or Apex, directly into an Extension Cable or directly into a Humminbird® Helix Adapter Cable.

EXTENSION CABLES - The Dual Spectrum CHIRP cable from the trolling motor may not be long enough to reach your fish finder. If the cable length does not reach the desired fish finder installation location, extension cables are available. A 10-foot extension cable ([EC M3 14W10 - 10' transducer extension cable - 720106-1](#)) and a 30-foot extension cable ([EC M3 14W30 - 30' transducer extension cable - 720106-2](#)) are available from humminbird.johnsonoutdoors.com. Both the 10-foot and 30-foot extension cables also come "Apex and Solix Ready". The Extension Cables may plug directly into a Solix or Apex or directly into a Helix Adapter Cable.

HUMMINBIRD HELIX ADAPTER CABLES - If connecting to a Humminbird® Helix fish finder, an adapter cable accessory is included that will allow the connection of any compatible Humminbird® Helix fish finder. The Helix adapter cable will plug directly into the Helix fish finder.

OTHER FISH FINDER ADAPTER CABLES - If connecting to other fish finders on the market, check for compatibility or any required adapter cables online at minnkota.johnsonoutdoors.com.

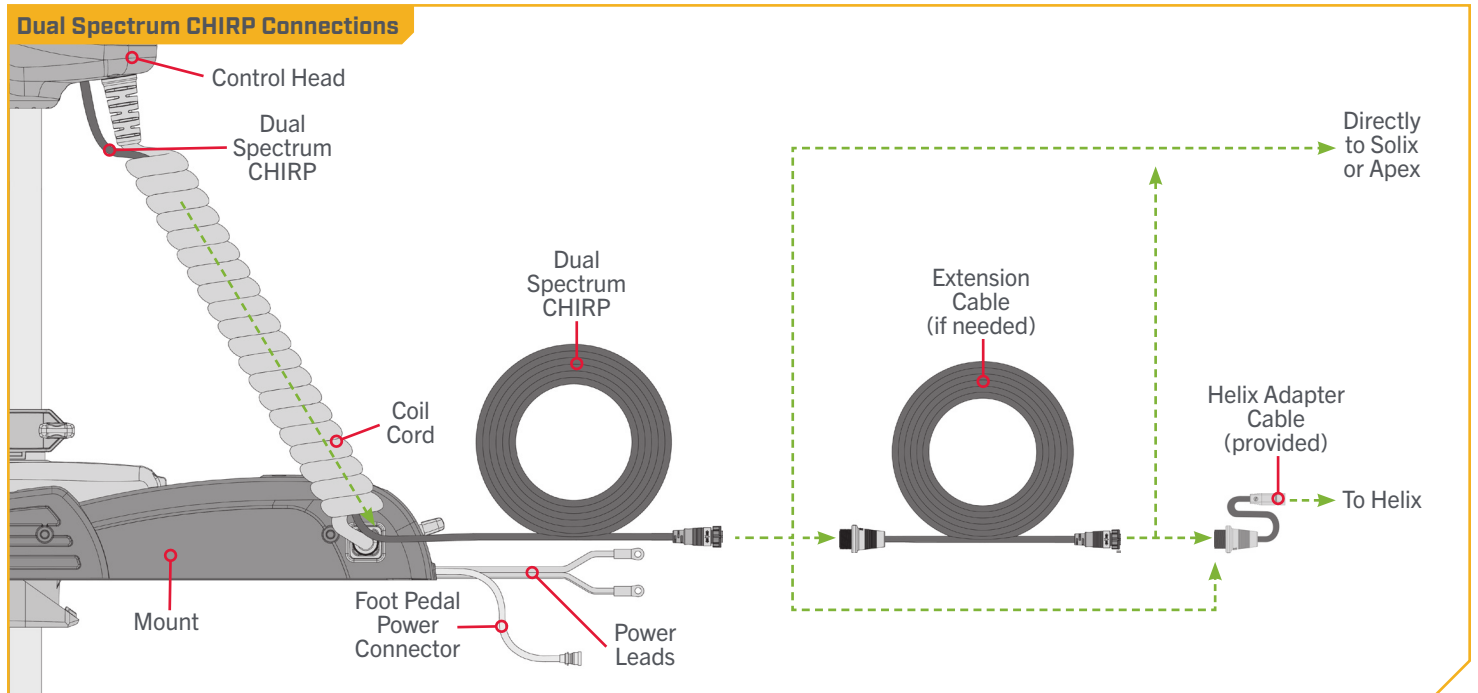

All Dual Spectrum CHIRP PowerDrive motors are equipped with an internal bonding wire. Incorrect rigging will cause sonar interference and can damage your trolling motor, electronics, and other boat accessories. To minimize trolling motor interference, ensure that the fish finder and trolling motor are powered by separate batteries. Please refer to the "Battery & Wiring Installation" and "Motor Wiring Diagram" sections of this manual for correct rigging instructions.

The Dual Spectrum CHIRP cables are shielded to minimize interference. To protect this shielding, the cables should not be pulled tight against sharp angles or hard objects. If using cable ties, do not over-tighten. Any excess cable should be bundled in a loose loop of no less than 4" in diameter. The connection cable should be routed to the fish finder following Minn Kota recommendations on routing the cables to optimize mobility and maximize functionality. Follow the instructions below for completing all connections and then follow the instructions for "Securing Accessory Cables" to complete the output cable installation.

CAUTION

Failure to follow the recommended wire routing for installed features, if equipped, may cause damage to the product and void your product warranty. Route cables away from pinch points or other areas that may cause them to bend in sharp angles. Routing the cables in any way other than directed may cause damage to the cables by being pinched or severed. Do not over-tighten the cable ties as it may damage the wires.

1

NOTICE: Your fish finder should be turned off until this procedure is complete.

- a. Place the motor in the deployed position.
- b. Locate the Fourteen Pin Connector on the end of the Dual Spectrum CHIRP accessory cable. The cable will exit the base of the Control Head and run down the center of the Coil Cord.
- c. Determine if the Plug on the end of the Dual Spectrum CHIRP accessory cable will be attached directly to:
 - 1) a Humminbird® Solix or Apex fish finder,
 - 2) a Dual Spectrum CHIRP Extension Cable,
 - 3) a Helix Adapter Cable or a compatible fish finder adapter cable.

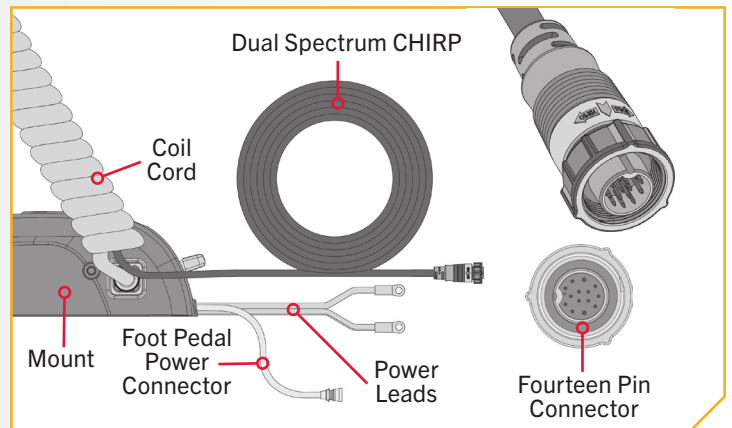

DUAL SPECTRUM CHIRP



2

- d. If installing directly to a Solix or Apex, the connection will be flat on the back of the fish finder display.
- e. Align the pins on the Accessory Cable with the receptacle on the fish finder. Notice the keyed connectors. Tighten the Collar from the accessory cable to secure the connection. Once directly installed to the Solix or Apex, the connection is complete.

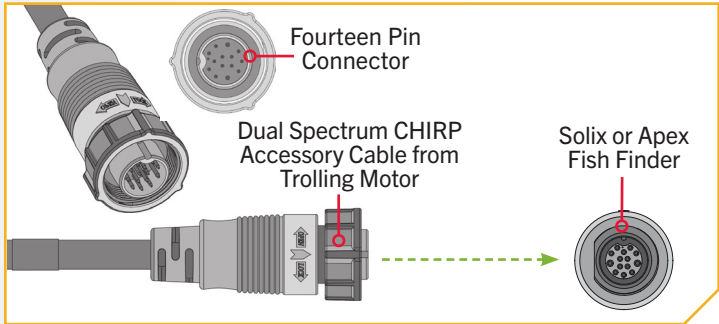

3

- f. If installing directly to a Dual Spectrum CHIRP Extension Cable, align the pins on the accessory cable with the receptacle on the extension cable. Notice the keyed connectors. Tighten the Collar from the accessory cable to secure the connection.
- g. If the Dual Spectrum CHIRP extension cable will be attached directly to a Humminbird® Solix or Apex, the connection will look exactly like the installation directly into a Humminbird Solix or Apex fish finder.

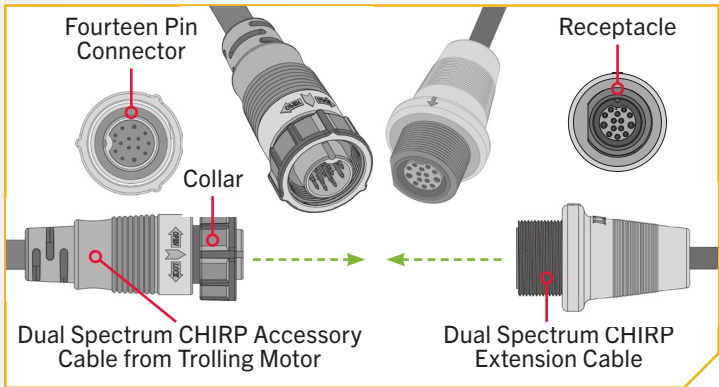

NOTICE: A 10-foot extension cable (EC M314W10 - 10' transducer extension cable - 720106-1) and a 30-foot extension cable (EC M3 14W30 - 30' transducer extension cable - 720106-2) are available from humminbird.johnsonoutdoors.com.



4

ITEM(S) NEEDED



- h. If installing directly to a Helix Adapter Cable, align the pins on the accessory cable or extension cable with the receptacle on the Helix Adapter Cable (Item #18). Notice the keyed connectors. Tighten the Collar from the accessory cable or extension cable to secure the connection.
- i. If the Helix Adapter Cable will be attached directly to a Humminbird® Helix, plug it in the Helix Adapter Cable Keyed Connection on the back of the fish finder.

NOTICE: If connecting to other fish finders on the market, check for compatibility or any required adapter cables online at minnkota.johnsonoutdoors.com.

- j. If your trolling motor has more than one external connector for an output device, complete the connection for that specific output and then follow the instructions for "Securing Accessory Cables" to complete the output cable installation.

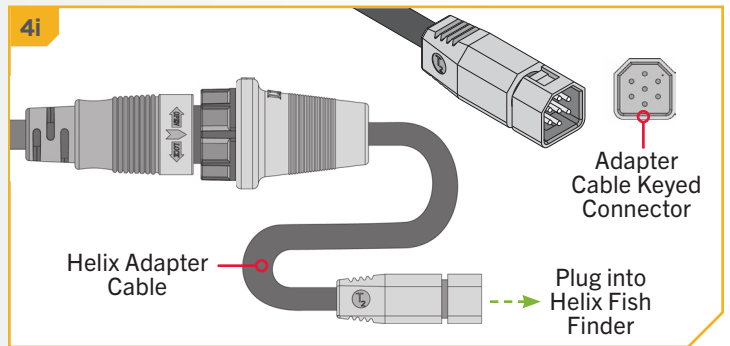
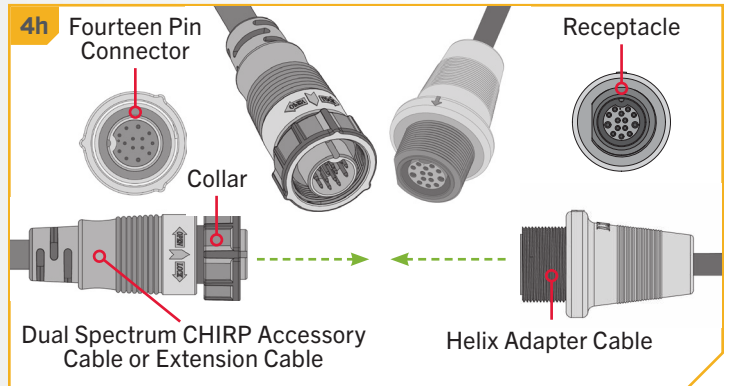

NOTICE: If unsure of what features your trolling motor may be installed with that require connection to an output device, please review the "Identifying Trolling Motor Features And Their Associated Cables" in this document.

ADVANCED GPS NAVIGATION



ADVANCED GPS NAVIGATION >

Your Minn Kota trolling motor and Humminbird fish finder communicate with each other to change the way you fish. Advanced GPS Navigation offers a large array of features including controlling speed, steering, Spot-Lock, and the ability to record and retrace tracks on the water, all at your fingertips. To learn more about the GPS capabilities available with your new motor, please refer to the Advanced GPS Navigation Owner's Manual by visiting minnkota.johnsonoutdoors.com.

The wireless remote and GPS controller make up the Advanced GPS Navigation system. A wireless remote comes paired to the controller from the factory. The GPS controller contains a very sensitive compass and is where all GPS satellite and remote signals are received. The GPS controller is located in the trolling motor Control Head and may be connected to a fish finder from an Accessory Cable that exits the Control Head. If the Advanced GPS Navigation system will be used with a fish finder, the Ethernet link between the trolling motor and the fish finder must be connected.

> Considerations for Connecting and Routing Advanced GPS Navigation

If Advanced GPS Navigation is pre-installed on your trolling motor, one eight pin Advanced GPS Ethernet Connector will exit the base of the Control Head and rest just below the Control Head next to the Coil Cord and one Advanced GPS Cable will exit the base of the Control Head and run down the center of the Coil Cord. The Advanced GPS Cable will come to a "Y" near the Mount of the trolling motor. One half of the "Y" will enter the Mount next to the Power Leads and the main portion of the cable will be attached from the factory to the Foot Pedal Power Connector. The Advanced GPS Cable that comes to a "Y" near the mount is pre-installed and should be left in place. If a trolling motor is equipped with Advanced GPS Navigation, it will not be equipped with a Foot Pedal. If the Advanced GPS Navigation on the trolling motor will be used with a fish finder, an Ethernet Cable will need to be attached to the Advanced GPS Ethernet Connector below the Control Head. Consider the distance between the trolling motor and the fish finder to determine how to complete the Ethernet connection.

ETHERNET CABLES - Minn Kota provides one 30 ft Ethernet cable ([AS EC 30E - 30' Ethernet Cable - 720073-4](#)) with every trolling motor equipped with Advanced GPS Navigation. The 30 ft Ethernet cable will accommodate a standard Ethernet connection for most installations to a Humminbird fish finder and is "Apex and Solix Ready". If the distance between the trolling motor and Humminbird fish finder is relatively small and a shorter cable is preferred, alternate cable lengths are available from humminbird.johnsonoutdoors.com. These options include:

- 10 ft - ([AS EC 10E - 10' Ethernet Cable - 720073-2](#))
- 15 ft - ([AS EC 15E - 15' Ethernet Cable - 720073-5](#))
- 20 ft - ([AS EC 20E - 20' Ethernet Cable - 720073-3](#))

Every length of Ethernet cable plugs directly into a Solix or Apex or directly into a Helix Adapter Cable.

HUMMINBIRD HELIX ADAPTER CABLES - Minn Kota provides one Helix Adapter Cable ([AS EC QDE - Ethernet Adapter Cable - 720074-1](#)) with every trolling motor equipped with Advanced GPS Navigation. If the Ethernet connection is being made between the trolling motor and any Humminbird® Helix fish finder, the Helix Adapter Cable should be used. The Helix Adapter Cable directly connects the Ethernet Cable to a Helix fish finder.

ETHERNET EXTENSION CABLES - If the 30 ft Ethernet cable provided with your trolling motor with Advanced GPS Navigation is not long enough to reach the fish finder, an Ethernet Extension cable should be used. The Ethernet Extension cable is available from humminbird.johnsonoutdoors.com and is available in a 30 ft length ([AS ECX 30E - 30' Ethernet Extension Cable - 760025-1](#)). The Ethernet Extension Cable will plug directly into any length of Ethernet cable.

NOTICE: Minn Kota recommends routing the Ethernet Cable or Ethernet Extension Cable through the Coil Cord when making the Ethernet connection. The cables will be installed from the Mount to the Control Head through the Coil Cord and parallel to the Advanced GPS Cable. Bypassing the Coil Cord when routing the Ethernet Cable or Ethernet Extension Cable is not recommended.

GPS Ethernet Connection

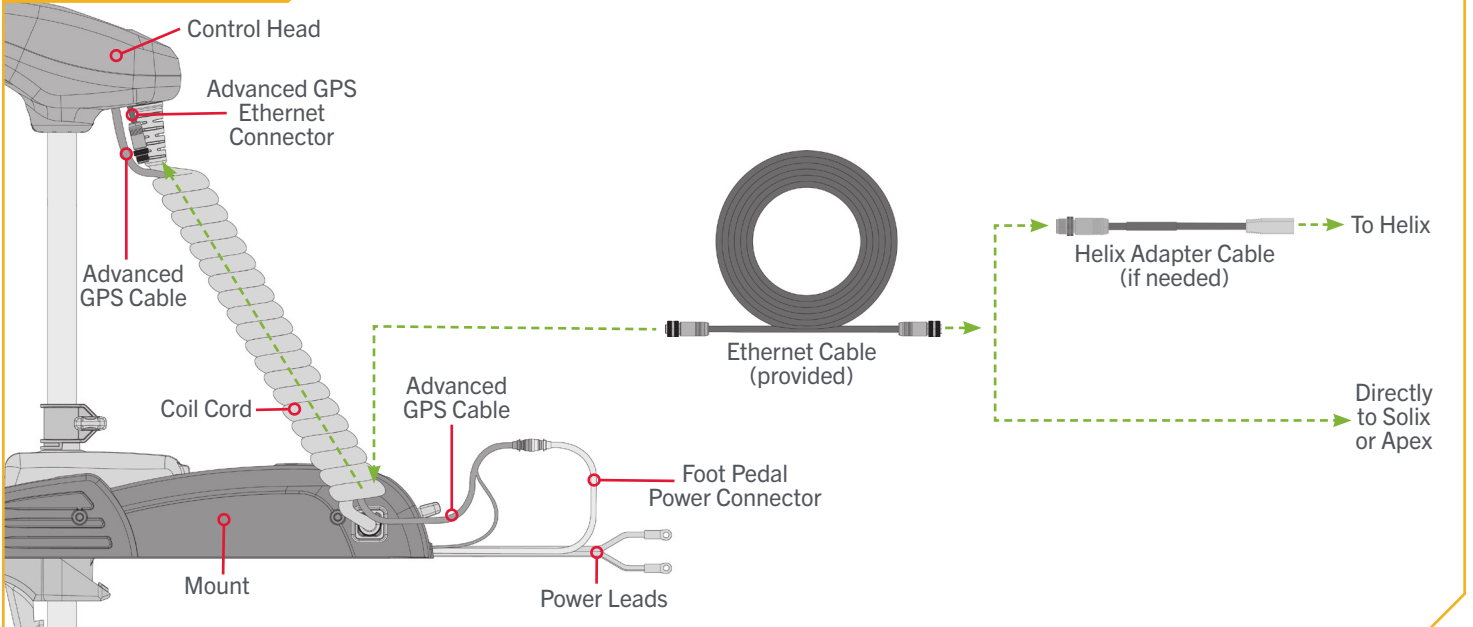

CAUTION

Failure to follow the recommended wire routing for installed features, if equipped, may cause damage to the product and void your product warranty. Route cables away from pinch points or other areas that may cause them to bend in sharp angles. Routing the cables in any way other than directed may cause damage to the cables by being pinched or severed. Do not over-tighten cable ties as it may damage the wires.

1

NOTICE: Your fish finder should be turned off until this procedure is complete.

- a. Place the motor in the deployed position.
- b. Locate the Eight Pin Advanced GPS Ethernet Connector below the Control Head. The Advanced GPS Ethernet Connector will exit the base of the Control Head and will rest just below the Control Head next to the Coil Cord.

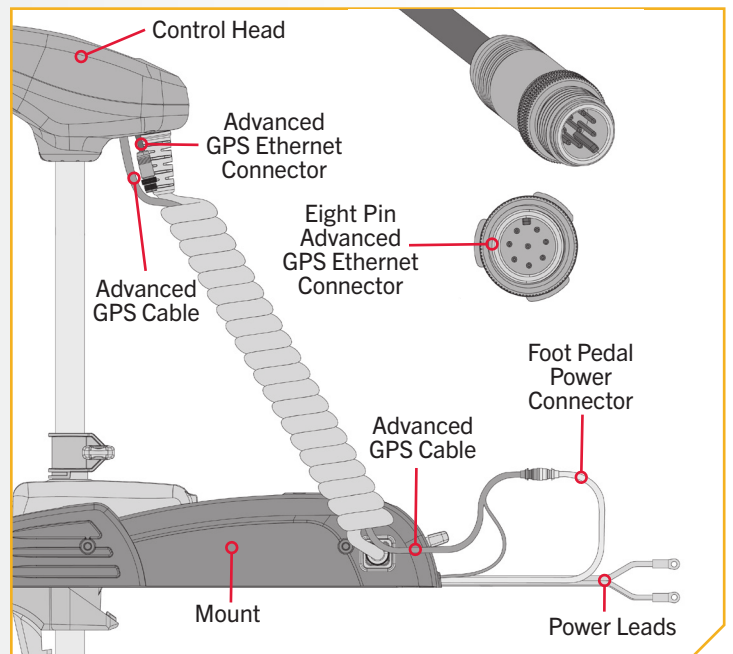

ADVANCED GPS NAVIGATION

2

ITEM(S) NEEDED



#15 x 1

- c. Take the Ethernet Cable (Item #15) and identify the Receptacle on either end. It will be keyed to fit with the Eight Pin Advanced GPS Ethernet Connector below the Control Head.

NOTICE: The Ethernet Cable has a Receptacle for the Advanced GPS Ethernet Connector on both ends and either end may be connected.

- d. Leading with either Receptacle, take the cable and fish it through the center of the Coil Cord starting at the end of the Coil Cord attached to the Mount and working up towards the Control Head. The cable will run parallel to the Advanced GPS Cable. Allow enough slack in the cable to attach the Receptacle to the Advanced GPS Ethernet Connector.

NOTICE: The 30' Ethernet Cable ([AS EC 30E - 30' Ethernet Cable - 720073-4](#)) is provided. If an alternate length is preferred, alternate cable lengths are available from [humminbird.johnsonoutdoors.com](#).

NOTICE: The 30' Ethernet Extension Cable ([AS ECX 30E - 30' Ethernet Extension Cable - 760025-1](#)) is available from [humminbird.johnsonoutdoors.com](#) and should be used if the standard 30' Ethernet Cable provided with your trolling motor is not long enough to reach the fish finder.

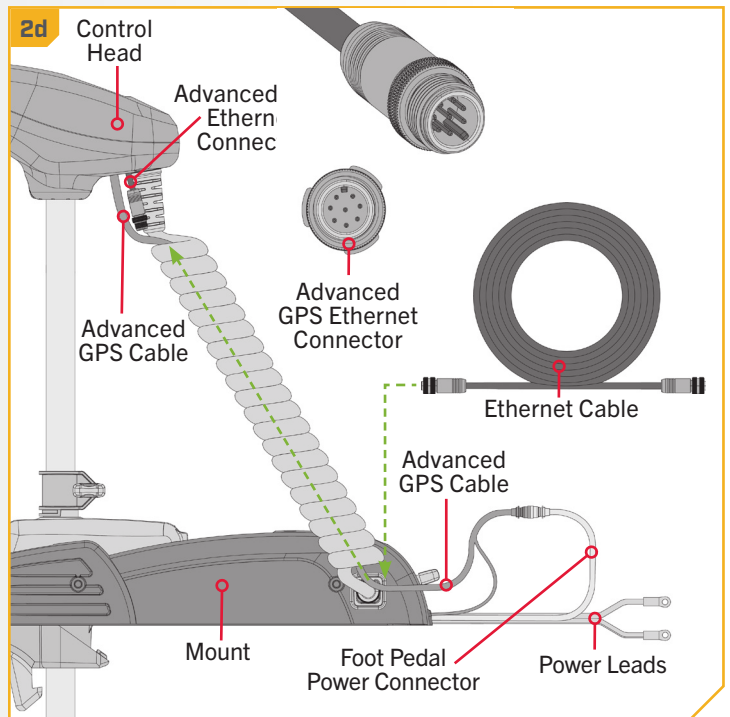
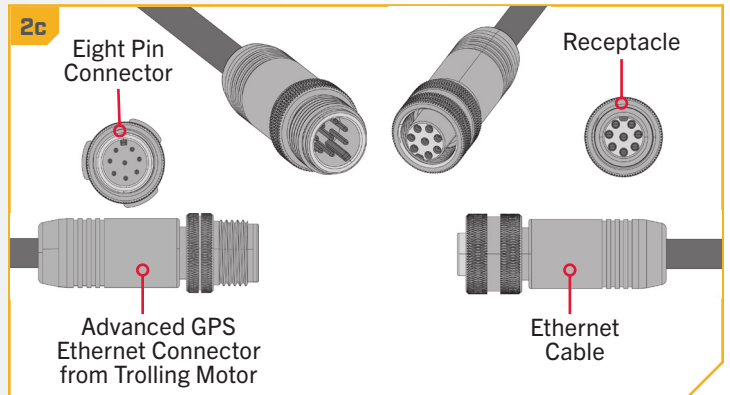

3

NOTICE: Minn Kota recommends routing the Ethernet Cable through the Coil Cord when making the Ethernet connection. The cable will be installed from the Mount to the Control Head through the Coil Cord and parallel to the Advanced GPS Cable. Bypassing the Coil Cord when routing the Ethernet Cable is not recommended.

- e. To install the Ethernet Cable, align the pins on the Advanced GPS Ethernet Connector with the Receptacle on the Ethernet Cable. Notice the keyed connectors. Press the ends together and tighten the Collar from the Ethernet Cable to secure the connection.
- f. The Ethernet Cable will plug directly into a Solix or Apex Fish Finder or directly into a Helix Adapter Cable.

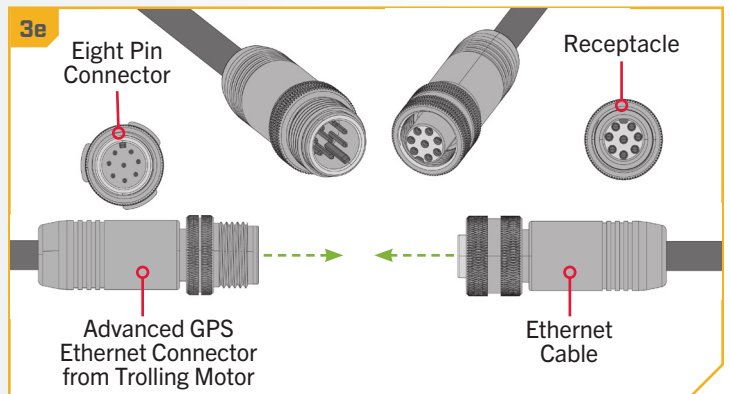
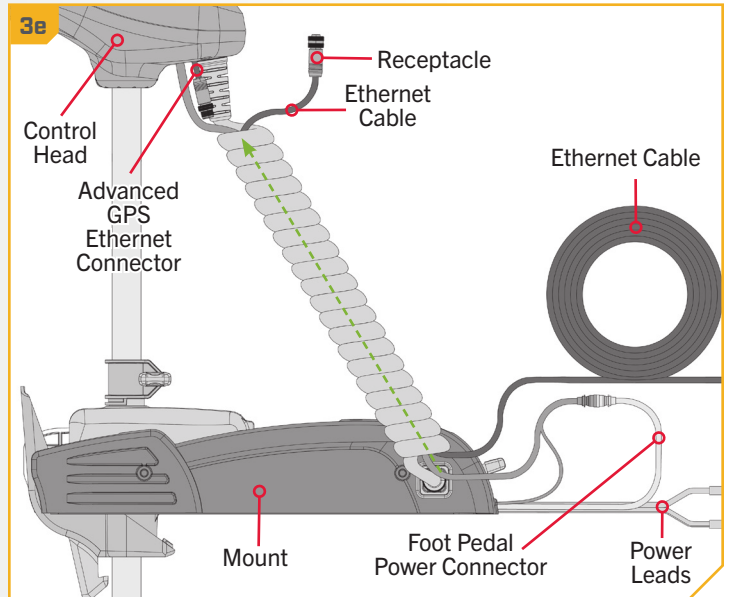

4

- g. If installing directly to a Solix or Apex, the connector will be flat on the back of the fish finder display.
- h. Align the Receptacle on the Ethernet Cable with the Eight Pin Connector on the Apex or Solix fish finder. Notice the keyed connectors. Tighten the Collar from the Ethernet Cable to secure the connection. Once directly installed to the Solix or Apex, the connection is complete.

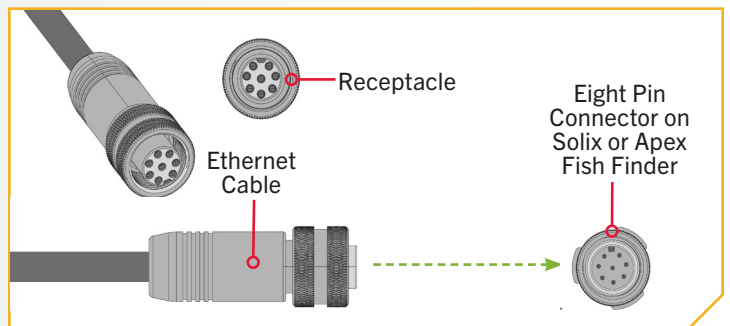

ADVANCED GPS NAVIGATION

5

ITEM(S) NEEDED



- i. If installing directly to a Helix Adapter Cable (Item #16), align the Receptacle on the Ethernet Cable with the Eight Pin Connector on the Helix Adapter Cable provided. Notice the keyed connectors. Tighten the Collar from the Ethernet Cable to secure the connection.

NOTICE: Minn Kota provides one Helix Adapter Cable (AS EC QDE - Ethernet Adapter Cable - 720074-1) with every trolling motor equipped with Advanced GPS Navigation.

- j. The Helix Adapter Cable directly connects the Ethernet Cable to a Helix fish finder. Locate the Helix Adapter Cable Keyed Connector on the back of the fish finder. Plug the Helix Adapter Cable into the back of the Helix fish finder to complete the connection.
- k. If your trolling motor has more than one external connector for an output device, complete the connection for that specific output and then follow the instructions for "Securing Accessory Cables" to complete the output cable installation.

NOTICE: If unsure of what features your trolling motor may be installed with that require connection to an output device, please review the "Identifying Trolling Motor Features and Their Associated Cables" section of this manual.

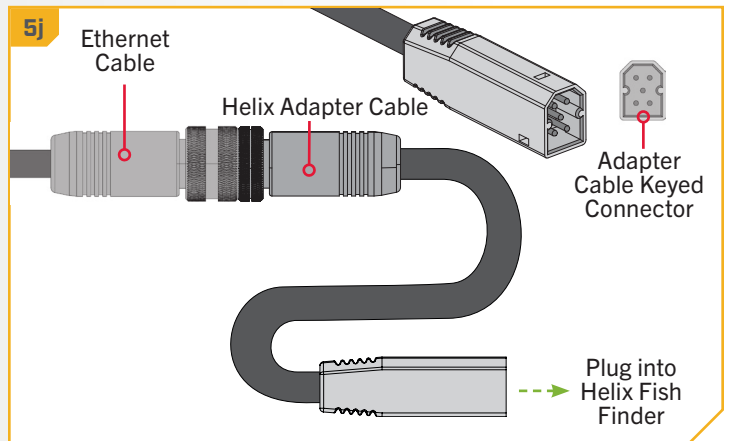
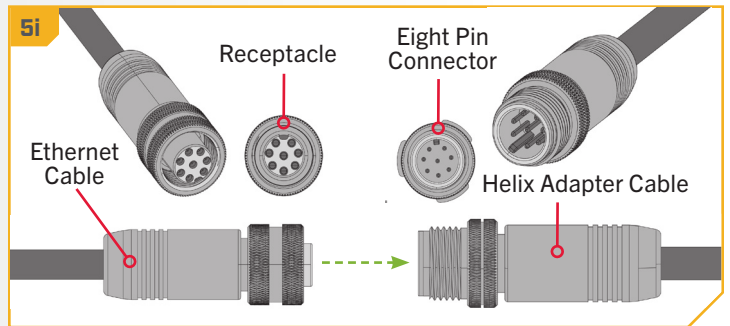

› Securing Accessory Cables

Before securing the Accessory Cables, please review the "Identifying Trolling Motor Features and Their Associated Cables" section of this document. When identifying features, it is very important to secure the cables if **two or more** connections are present below the Control Head. If only **one** cable is present below the Control Head, this installation is not applicable. All Accessory Cables that will be used on the trolling motor must be routed, and all connections secured before completing the installation in this section. To review how Accessory Cables should be routed and connected, please review the "Dual Spectrum CHIRP" and "Advanced GPS Navigation" sections of this document.

NOTICE: If only one cable is present below the Control Head, this installation is not applicable.

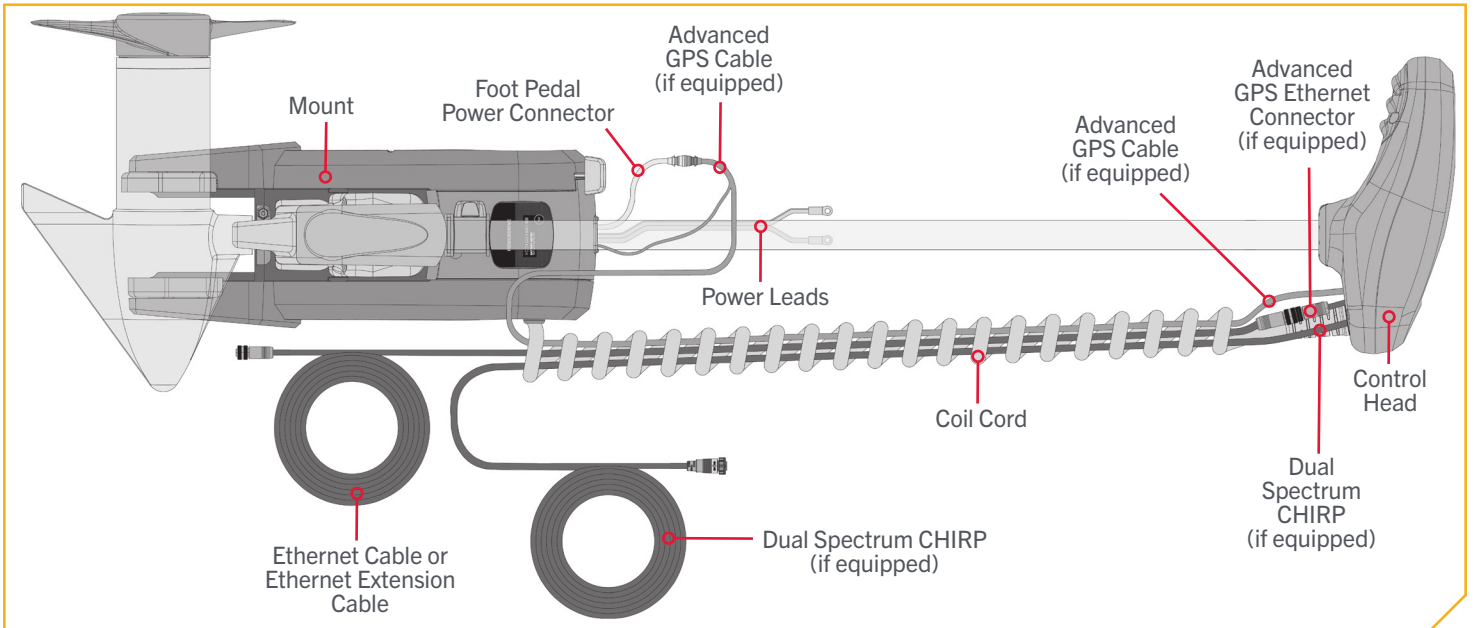

⚠ CAUTION

Failure to follow the recommended wire routing for installed features, if equipped, may cause damage to the product and void your product warranty. Route cables away from pinch points or other areas that may cause them to bend in sharp angles. Routing the cables in any way other than directed may cause damage to the cables by being pinched or severed. Do not over-tighten the cable ties as it may damage the wires.

1

- a. Begin with the Trolling Motor in the stowed position and have all Accessory Cables identified, routed and connected.
- b. If equipped with Advanced GPS Navigation, the Advanced GPS Ethernet Connector should be present just below the Control Head next to the Coil Cord. Locate the Advanced GPS Ethernet Connector below the Control Head.

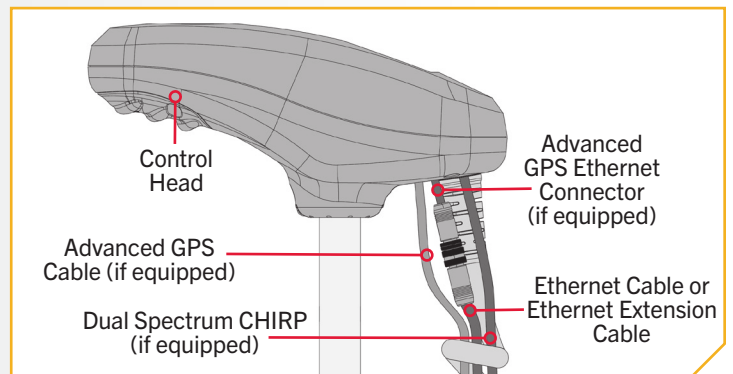

SECURING ACCESSORY CABLES

2

ITEM(S) NEEDED

———— #17 x 1

- c. Check the Accessory Cables and confirm that the cables that are connected run parallel down the center of the Coil Cord.
- d. While the motor is in the stowed position, straighten the Accessory Cables so they run neatly from the Control Head to the Mount.
- e. Starting approximately 4 inches below the Control Head, take a Cable Tie (Item #17) and place it around the Connection Cables inside the Coil Cord.

NOTICE: Do NOT secure the Accessory Cable to the Coil Cord. ONLY secure the Accessory Cables with the Cable Ties to the other Accessory Cables. Keep factory Cable Ties in place.

- f. Secure the Cable Tie around the Accessory Cables until it is fingertip tight. Do not over-tighten the Cable Tie as it will cause damage to the Accessory Cables.

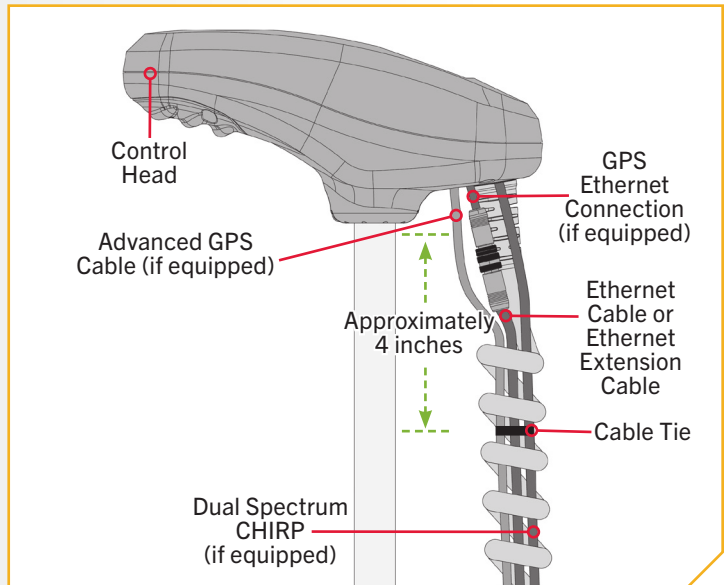

CAUTION
Do not over-tighten the Cable Ties as it may damage the wires.

3

- g. Follow the Accessory Cables from the Control Head to the Mount and place additional Cable Ties every 4 inches around the Accessory Cables after the first Cable Tie. The number of Cable Ties needed will vary depending on the length of your trolling motor Shaft.

NOTICE: If additional Cable Ties are needed, a Service Assembly (#2996300 TIE WRAP ASM, 60") is available from the Parts Ordering Portal at minnkota.johnsonoutdoors.com.

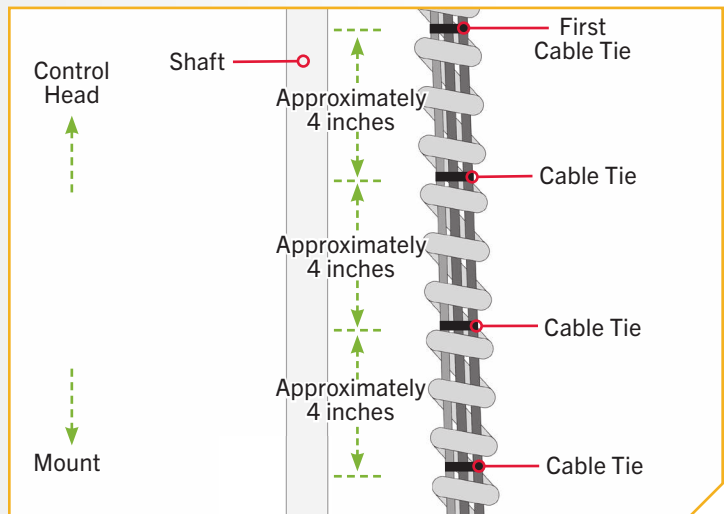

SECURING ACCESSORY CABLES

4

- h. Continue placing Cable Ties around the Accessory Cables until the cables exit the Coil Cord next to the Mount, when the Motor is in the stowed position. The Cable Ties should be placed approximately every 4 inches.
- i. After the Accessory Cables exit the Coil Cord continue to secure the cables every 4 inches until there are two Cable Ties in place on the Accessory Cables after the Coil Cord.

NOTICE: Secure the Cable Ties fingertip tight. It is recommended to have them **ONLY** tight enough so that they do not slide around on the Accessory Cables and hold the cables together.

- j. Any excess cable should be bundled in a loose loop of no less than four inches in diameter. Use the Reusable Cable Tie provided to secure additional Accessory Cables, if present, once the cable routing is complete.

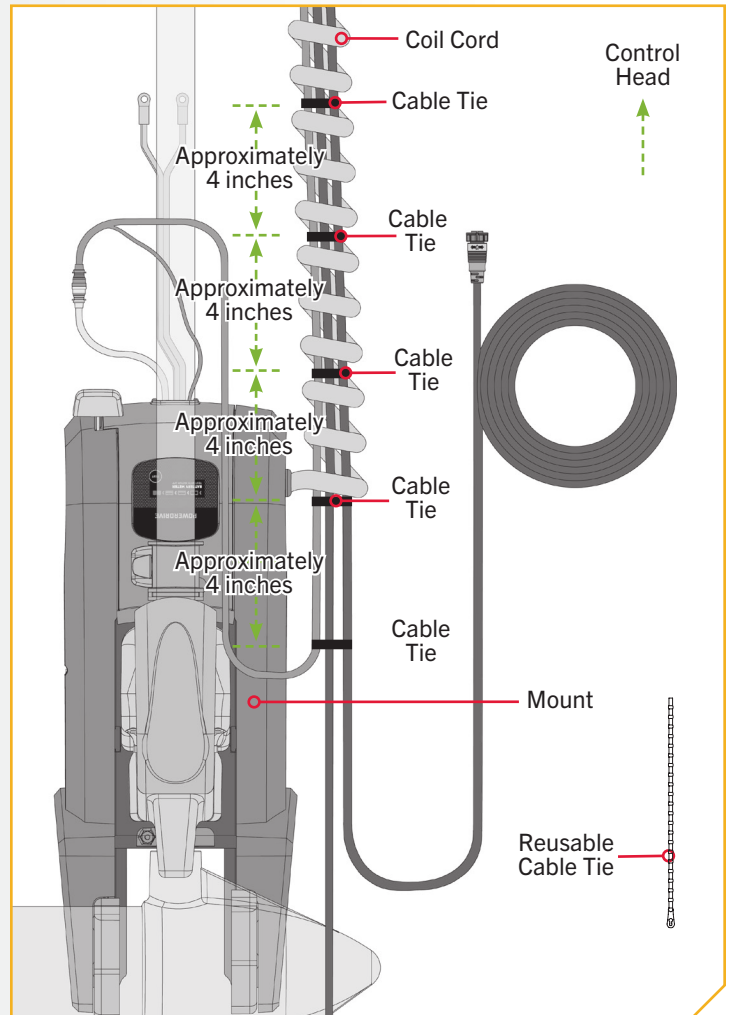

BATTERY & WIRING INSTALLATION

BOAT RIGGING & PRODUCT INSTALLATION

For safety and compliance reasons, we recommend that you follow American Boat and Yacht Council (ABYC) standards when rigging your boat. Altering boat wiring should be completed by a qualified marine technician. The following specifications are for general guidelines only:

CAUTION

These guidelines apply to general rigging to support your Minn Kota motor. Powering multiple motors or additional electrical devices from the same power circuit may impact the recommended conductor gauge and circuit breaker size. If you are using wire longer than that provided with your unit, follow the conductor gauge and circuit breaker sizing table below. If your wire extension length is more than 25 feet, we recommend that you contact a qualified marine technician.

CAUTION

An over-current protection device (circuit breaker or fuse) must be used. Coast Guard requirements dictate that each ungrounded current-carrying conductor must be protected by a manually reset, trip-free circuit breaker or fuse. The type (voltage and current rating) of the fuse or circuit breaker must be sized accordingly to the trolling motor used. The table below gives recommended guidelines for circuit breaker sizing.

CONDUCTOR GAUGE AND CIRCUIT BREAKER SIZING TABLE

This conductor and circuit breaker sizing table is only valid for the following assumptions:

1. No more than 2 conductors are bundled together inside of a sheath or conduit outside of engine spaces.
2. Each conductor has 105° C temp rated insulation.
3. No more than 3% voltage drop allowed at full motor power based on published product power requirements.

Motor Thrust / Model	Max Amp Draw	Circuit Breaker		Wire Extension Length				
		Amps	Minimum	5 feet	10 feet	15 feet	20 feet	25 feet
42 lb., 45 lb.	42	50 Amp	12 VDC	8 AWG	6 AWG	4 AWG	2 AWG	2 AWG
50 lb., 55 lb.	50	60 Amp	12 VDC	8 AWG	4 AWG	2 AWG	2 AWG	1 AWG
70 lb.	42	50 Amp	24 VDC	8 AWG	8 AWG	6 AWG	6 AWG	4 AWG

NOTICE: Wire Extension Length refers to the distance from the batteries to the trolling motor leads. Consult website for available thrust options. Maximum Amp Draw values only occur intermittently during select conditions and should not be used as continuous amp load ratings.

Reference

United States Code of Federal Regulations: 33 CFR 183 – Boats and Associated Equipment ABYC E-11: AC and DC Electrical Systems on Boats

SELECTING THE CORRECT BATTERIES

The motor will operate with any lead acid, deep cycle marine 12 volt battery/batteries. For best results, use a deep cycle, marine battery with at least a 105 amp-hour rating. Maintain battery at full charge. Proper care will ensure having battery power when you need it, and will significantly improve the battery life. Failure to recharge lead-acid batteries (within 12-24 hours) is the leading cause of premature battery failure. Use a multi-stage charger to avoid overcharging. We offer a wide selection of chargers to fit your charging needs. If you are using a crank battery to start a gasoline outboard, we recommend that you use a separate deep cycle marine battery/batteries for your Minn Kota trolling motor. For more information on battery selection and rigging, please visit minnkota.johnsonoutdoors.com. Minn Kota trolling motors can run on Lithium Ion batteries. However, they are specifically designed to run on traditional lead acid batteries (flooded, AGM or GEL). Lithium Ion batteries maintain higher voltages for longer periods of time than lead acid. Therefore, running a Minn Kota trolling motor at speeds higher than 85% for a prolonged period could cause permanent damage to the motor.

WARNING

Never connect the (+) and the (-) terminals of the same battery together. Take care that no metal object can fall onto the battery and short the terminals. This would immediately lead to a short and extreme fire danger.

CAUTION

Refer to "Conductor Gauge and Circuit Breaker Sizing Table" in the previous section to find the appropriate circuit breaker or fuse for your motor. For motors requiring a 60-amp breaker, the Minn Kota MKR-19 60-amp circuit breaker is recommended.

CAUTION

Please read the following information before connecting your motor to your batteries in order to avoid damaging your motor and/or voiding your warranty.

ADDITIONAL CONSIDERATIONS

Using DC or Alternator Chargers

Your Minn Kota trolling motor may be designed with an internal bonding wire to reduce sonar interference. Most alternator charging systems do not account for this bonding wire, and connect the negative posts of the trolling motor batteries to the negative posts of the crank/starting battery. These external connections can damage connected electronics and the electrical system of your trolling motor, voiding your warranty. Review your charger's manual carefully or consult the manufacturer prior to use to ensure your charger is compatible.

Minn Kota recommends using Minn Kota brand chargers to recharge the batteries connected to your Minn Kota trolling motor, as they have been engineered to work with motors that include a bonding wire.

Additional Accessories Connected to Trolling Motor Batteries

Significant damage to your Minn Kota motor, your boat electronics, and your boat can occur if incorrect connections are made between your trolling motor batteries and other battery systems. Minn Kota recommends using an exclusive battery system for your trolling motor. Where possible, accessories should be connected to a separate battery system. Radios and sonar units should not be connected to any trolling motor battery systems as interference from the trolling motor is unavoidable. If connecting any additional accessories to any trolling motor battery system, or making connections between the trolling motor batteries and other battery systems on the boat, be sure to carefully observe the information below.

CONNECTING THE BATTERIES



The negative (-) connection must be connected to the negative terminal of the same battery that the trolling motor negative lead connects to. In the diagrams below this battery is labeled “Low Side” Battery. Connecting to any other trolling motor battery will input positive voltage into the “ground” of that accessory, which can cause excess corrosion. Any damage caused by incorrect connections between battery systems will not be covered under warranty.

› Automatic Jump Start Systems and Selector Switches

Automatic jump start systems and selector switches tie the negatives of the connected batteries together. Connecting these systems to the “High Side” Battery or “Middle” Battery in the diagrams below and will cause significant damage to your trolling motor and electronics. The only trolling motor battery that is safe to connect to one of these systems is the “Low Side” Battery.

NOTICE: The internal bonding wire is equipped with a 3 amp fuse. Improper connections described above carrying in excess of 3 amps will blow this fuse and no further damage will be exhibited. If this occurs, RF interference from the trolling motor affecting sonar units and other electronics will be more significant. If the fuse is blown the wiring error should be found and addressed prior to replacing the fuse. The replacement fuse should be 3 amps or less. An intact fuse does not imply correct rigging; significant damage can be done by incorrect wiring without approaching 3 amps of current.

CONNECTING THE BATTERIES

› 12 Volt Systems

1. Make sure that the motor is switched off (speed selector on “OFF” or “0”).
2. Connect positive (+) red lead to positive (+) battery terminal.
3. Connect negative (–) black lead to negative (–) battery terminal.

WARNING

For safety reasons do not switch the motor on until the propeller is in the water. If installing a leadwire plug, observe proper polarity and follow instructions in your boat owner’s manual.

WARNING

- For safety reasons, disconnect the motor from the battery or batteries when the motor is not in use or while the battery/batteries are being charged.
- Improper wiring of 24/36 volt systems could cause battery explosion.
- Keep leadwire wing nut connections tight and solid to battery terminals.
- Locate battery in a ventilated compartment.



CONNECTING THE BATTERIES IN SERIES

CONNECTING THE BATTERIES IN SERIES (IF REQUIRED FOR YOUR MOTOR)

24 Volt Systems

Two 12 volt batteries are required. The batteries must be wired in series, only as directed in wiring diagram, to provide 24 volts.

1. Make sure that the motor is switched off (speed selector on "0").
2. Connect a connector cable to the positive (+) terminal of battery 1 and to the negative (-) terminal of battery 2.
3. Connect positive (+) red motor lead to positive (+) terminal on battery 2.
4. Connect negative (-) black motor lead to negative (-) terminal of battery 1.

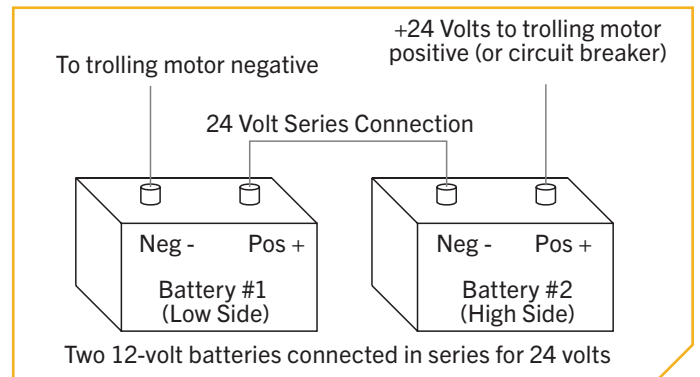

WARNING

For safety reasons do not switch the motor on until the propeller is in the water. If installing a leadwire plug, observe proper polarity and follow instructions in your boat owner's manual.

WARNING

- For safety reasons, disconnect the motor from the battery or batteries when the motor is not in use or while the battery/batteries are being charged.
- Improper wiring of 24/36 volt systems could cause battery explosion.
- Keep leadwire wing nut connections tight and solid to battery terminals.
- Locate battery in a ventilated compartment.

MOTOR WIRING DIAGRAM

POWERDRIVE

The following Motor Wiring Diagram applies to all PowerDrive models that do not come factory installed with Advanced GPS Navigation. Dual Spectrum CHIRP is an optional feature that may come factory installed. Motors without Advanced GPS Navigation may come with a Foot Pedal.

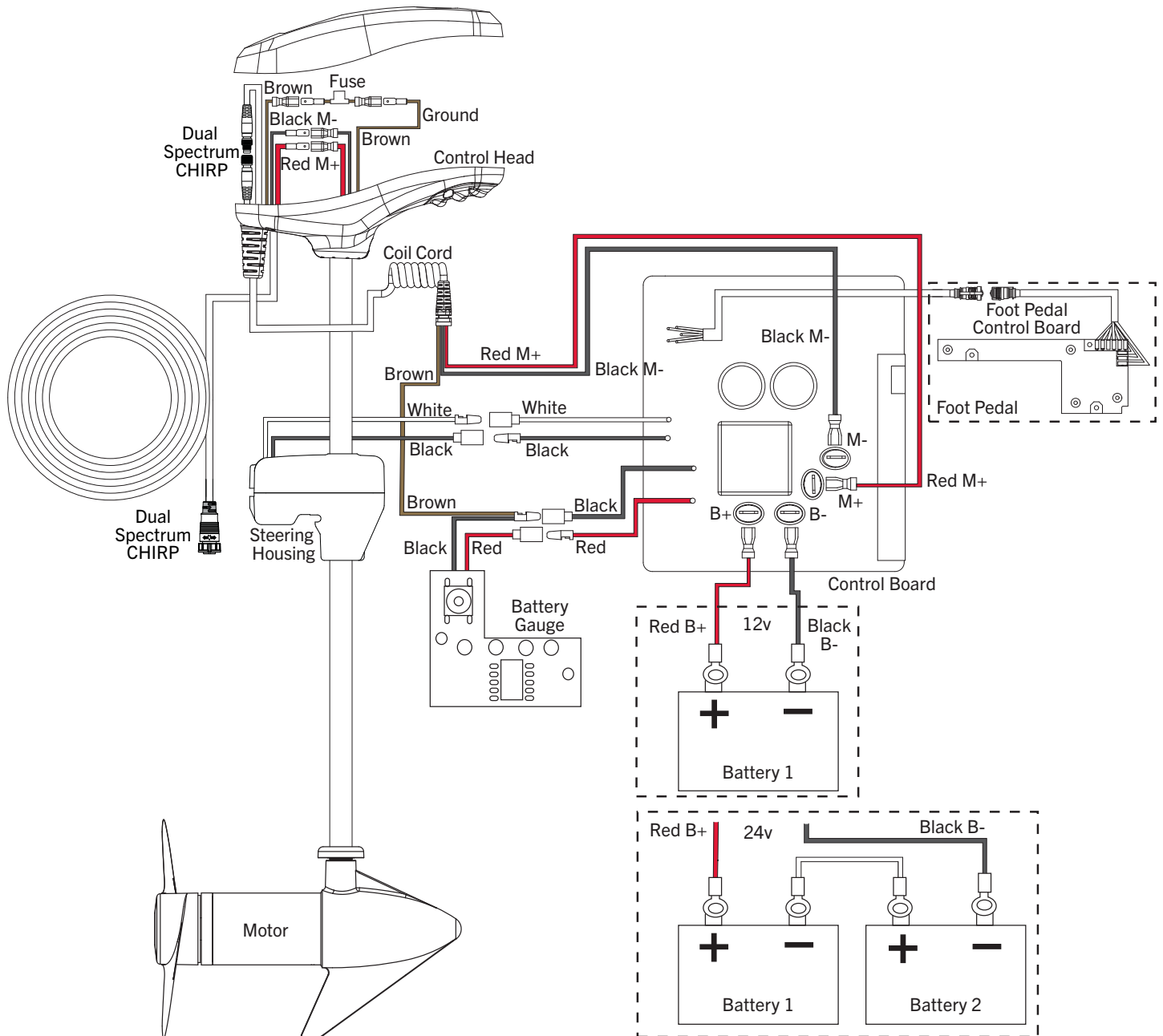

NOTICE: This is a multi-voltage diagram. Double-check your motor's voltage for proper connections. Over-Current Protection Devices are not shown in this illustration.

POWERDRIVE WITH ADVANCED GPS NAVIGATION

POWERDRIVE WITH ADVANCED GPS NAVIGATION

The following Motor Wiring Diagram applies to all PowerDrive models that come factory installed with Advanced GPS Navigation. Dual Spectrum CHIRP is an optional feature that may come factory installed.

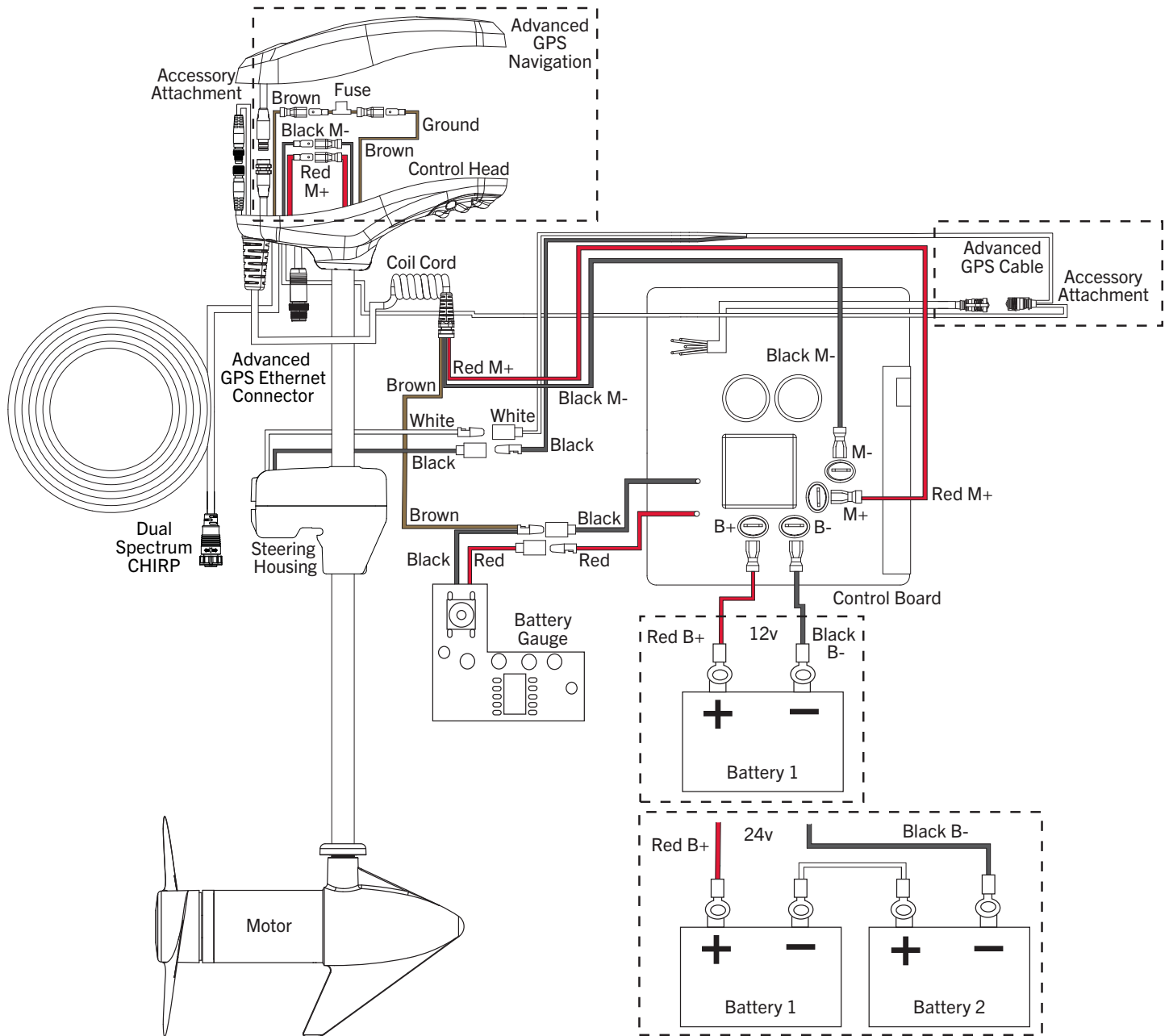

NOTICE: This is a multi-voltage diagram. Double-check your motor's voltage for proper connections. Over-Current Protection Devices are not shown in this illustration.

USING & ADJUSTING THE MOTOR

POWERING UP THE TROLLING MOTOR

The PowerDrive has no power switch. When the Power Cables are connected to a battery, the PowerDrive is "on". When the Power Cables are disconnected from the battery, the PowerDrive is "off". If the Power Cables are connected to a breaker that is connected to the battery, the PowerDrive is "on" when the breaker is "on" and "off" when the breaker is "off".

MOUNT FEATURES

Become familiar with the features of the motor to maximize the capabilities this product offers.

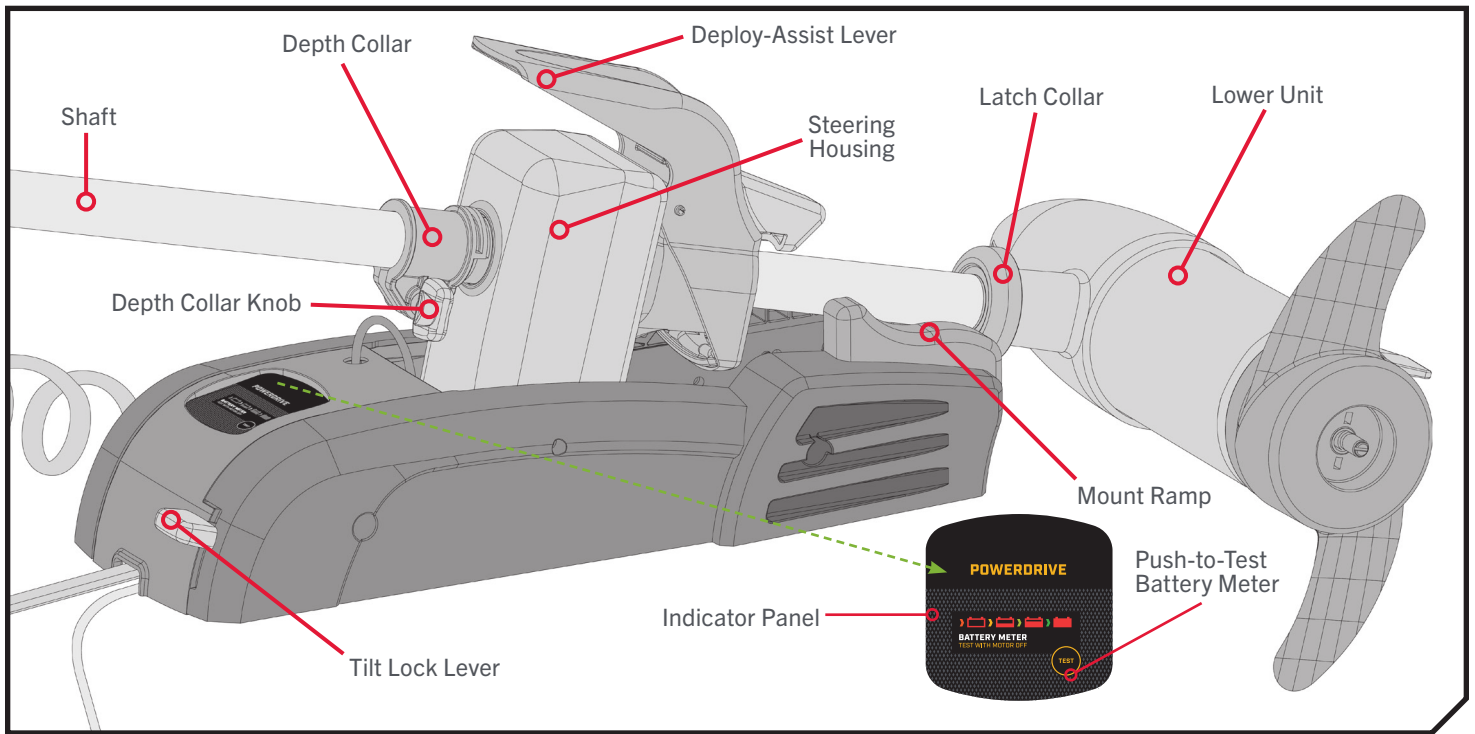

› Depth Collar & Depth Collar Knob

The Depth Collar is located on the Shaft above the Steering Housing. It functions to hold the motor at the proper depth while deployed. It also functions to hold the Lower Unit in place when stowed while not in use and during transport. The Depth Collar Knob is used to loosen and tighten the Depth Collar so that it can be used to slide up and down the motor shaft.

⚠ WARNING

When the motor is being transported, it is important to place the Depth Collar snug against the Steering Housing and tighten. This provides a secure stow and holds the motor in place during transportation when it is subject to high levels of shock and vibration. Failure to secure the motor may result in injury or damage to the unit.

› Deploy-Assist Lever

The Deploy-Assist Lever is located at the top of the mount when the motor is in the stowed position. The Deploy-Assist Lever functions to unlatch the motor when it is stowed and press on the Latch Collar to assist in deploying the motor. The Deploy-Assist Lever also captures the Latch Collar when the motor is stowed, holding the motor in place so it can be secured with the Depth Collar.

STOWING AND DEPLOYING THE MOTOR

› Latch Collar

The Latch Collar is located on the motor shaft just above the Lower Unit. It functions to help secure the motor in place while it is stowed. When stowed the Latch Collar is captured in the Deploy-Assist Lever.

› Tilt Lock Lever

The Tilt Lock Lever is located at the base of the mount opposite of the Lower Unit. The Tilt Lock Lever is used to unlatch the Steering Housing from the stowed position so the motor can be tilted, pulled upwards and stowed.

› Mount Ramp

The Mount Ramp functions to hold the Lower Unit in place when the motor is stowed. The Lower Unit will rest on the Mount Ramp when stowed, helping to secure it in place.



WARNING

When stowing or deploying the motor, keep fingers clear of all hinge and pivot points and all moving parts.



WARNING

When the motor is being transported, it is important to place the Depth Collar snug against the Steering Housing and tighten. This provides a secure stow and holds the motor in place during transportation when it is subject to high levels of shock and vibration. Failure to secure the motor may result in injury or damage to the unit.

STOWING AND DEPLOYING THE MOTOR

› To Deploy the Motor

Loosen the Depth Collar, then push firmly down on the Deploy-Assist Lever to release the Latch Collar and slide the motor forward, out from the Mount Ramp. Lower the motor to the desired depth. Make sure it clicks into a secure, vertical position. Once at the desired depth, slide the Depth Collar against the Steering Housing and tighten.

› To Stow the Motor

Loosen the Depth Collar and depress the Tilt Lock Lever and raise the motor by pulling up on the composite shaft or control head. Pull the motor toward the stern until it rests securely on the Mount Ramp and the Deploy-Assist Lever captures the Latch Collar. Slide the Depth Collar down and secure it against the top of the Steering Housing to secure the motor in place and prevent accidental deployment.

› Push-To-Test Battery Meter

This motor is equipped with a Push-to-Test Battery Meter. The LED lights are located on the Indicator Panel on the Mount of the motor. The Battery Meter provides an accurate display of the remaining charge in the battery. It is only accurate when the motor is off. The meter reads as follows:

- One light indicates recharge.
- Two lights indicate low charge.
- Three lights indicate good charge.
- Four lights indicate full charge.



WARNING

When stowing or deploying the motor, keep fingers clear of all hinge and pivot points and all moving parts. Practice proper ergonomics when stowing and deploying the motor to prevent injury.

Indicator Panel

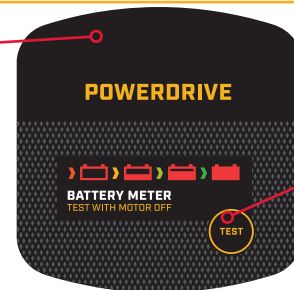

Push-to-Test Battery Meter

ADJUSTING THE DEPTH OF THE MOTOR

MOTOR ADJUSTMENTS >

> Adjusting the Depth of the Motor

Once the boat is on the water, it may be necessary to adjust the Lower Unit up or down to achieve an optimum depth for motor performance. When setting the depth of the motor, be sure the top of the motor is submerged at least 12" below the surface of the water to avoid churning or agitation of surface water.

- 1
 - a. With the motor in the deployed position, locate the Depth Collar on the Shaft above the Steering Housing.
 - b. While holding the Shaft, loosen the Depth Collar Knob until the Shaft can slide up and down freely.



WARNING

The Control Head will create a pinch point if the Depth Collar Knob is loosened and the Control Head slides to the top of the Depth Collar. Grasp the Shaft and prevent it from sliding all the way down to prevent the pinch point.

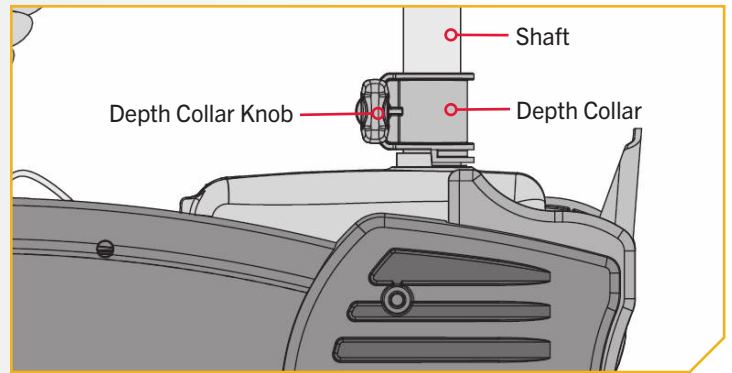

- 2
 - c. Raise or lower the motor to the desired depth.
 - d. Turn the motor control head to the desired position.
 - e. Slide the Depth Collar against the Steering Housing and tighten the Depth Collar Knob to secure the motor in place.

NOTICE: Be sure the top of the motor is submerged at least 12" below the surface of the water to avoid churning or agitation of surface water.

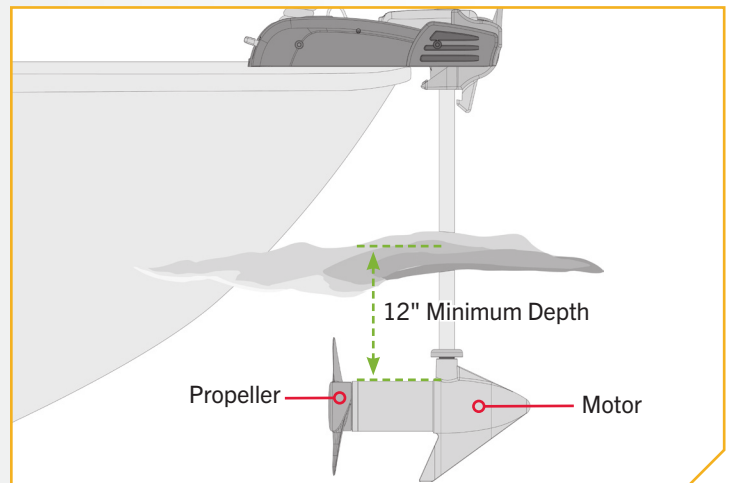

ADJUSTING THE LATCH COLLAR

Adjusting the Latch Collar

Once the motor has been used, it may be necessary to adjust the Latch Collar up or down. The ideal adjustment is a slightly loose fit that completely captures the Latch Collar in the Deploy Assist Lever when stowed.

1

- a. With the motor in the stowed position, locate the Latch Collar.
- b. Using a #2 Phillips Screwdriver, loosen the screw securing the Latch Collar in place.

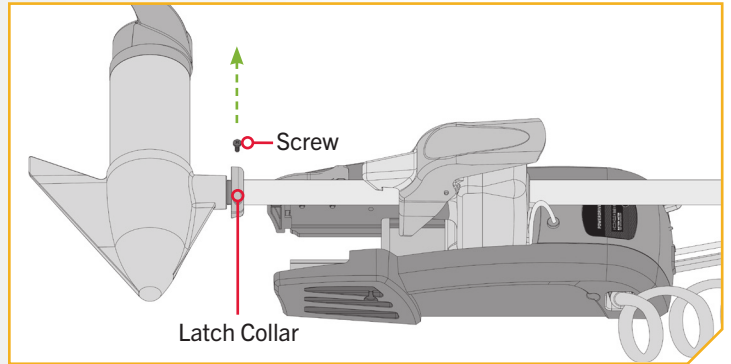

2

- c. Rotate the Latch Collar so it fits comfortably within the hold of the Deploy Assist Lever.
- d. Re-tighten the screw to secure the Latch Collar in place.

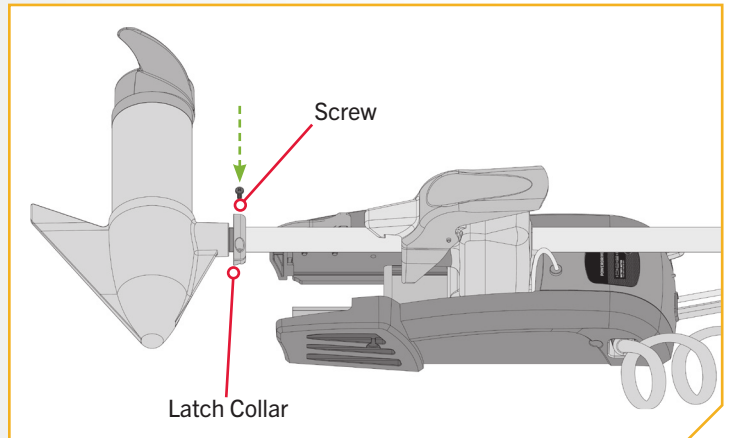

INSTALLING AN EXTERNAL TRANSDUCER

› Installing An External Transducer

Your trolling motor may be pre-installed with a Dual Spectrum CHIRP transducer system. If an external transducer is not included with your trolling motor. An external transducer can be installed onto the motor.

1

- a. Mount the External Transducer according to directions provided with the transducer.
- b. Leave enough slack in the Transducer Cable between the Lower Unit and Motor Control Head to allow the motor to properly stow and deploy.
- c. Use two Cable Ties to secure the Transducer Cable to the Shaft just above the Latch Collar and just below the Motor Control Head.
- d. Run the Transducer Cable through the Coil Cord to the fish finder.



CAUTION

Not following the recommended wire routing for the External Transducer may cause damage to the product and void your product warranty. Take care to test the length and placement of cable to be sure that there is enough slack where needed and that cables are free of being entangled in moving parts. Routing the cables in any way other than directed may cause damage to the cables by being pinched or severed.

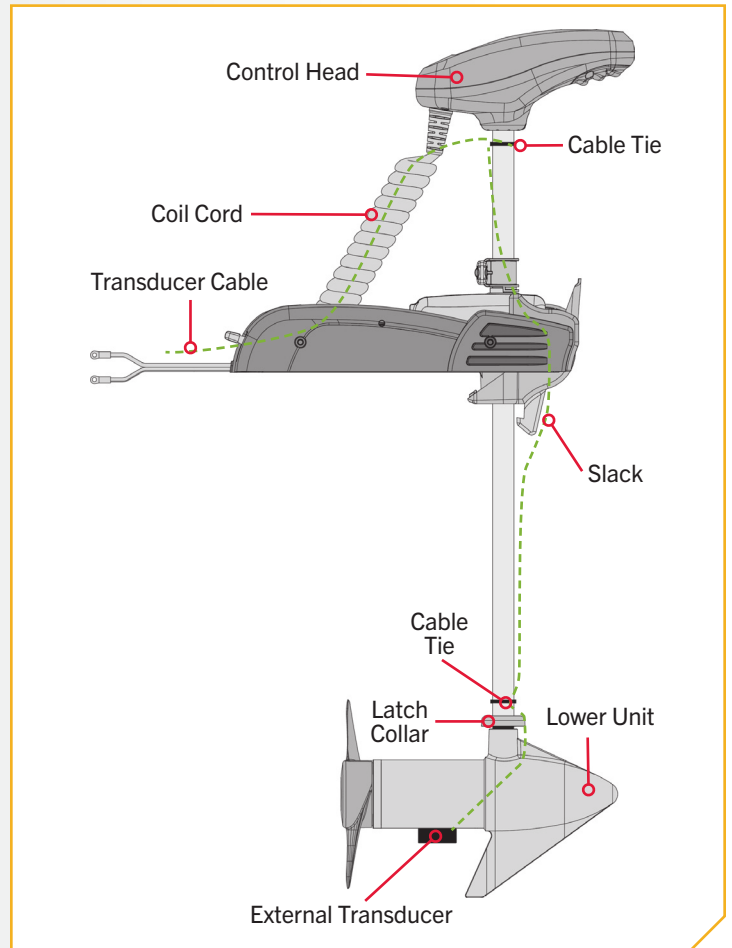

ADJUSTING THE LOWER UNIT FOR A SECURE STOW

› Adjusting The Lower Unit For A Secure Stow

When the Motor is stowed, the Lower Unit should rest on the Mount Ramp, a part of the Motor Mount. It is recommended to secure the motor using the following instructions to avoid damage to the motor and shaft from vibrations during transport.

1

- a. Before transporting the boat over water or land, stow the motor to determine where the Lower Unit rests on the Mount Ramp.

NOTICE: The correct positioning of the Lower Unit will place it directly on the Mount Ramps.

- b. If the Lower Unit does not sit on the Mount Ramps, refer to the Adjusting the Latch Collar section of this manual. Making adjustments to the Latch Collar will help the Lower Unit stay on the Mount Ramps as it is captured by the Deploy Assist Lever.



CAUTION

The Lower Unit should be placed on the Mount Ramps every time the motor is transported. If the Lower Unit is improperly placed, either above or below the Motor Rest Area, damage to the Lower Unit or Shaft will occur and the Shaft will be incorrectly captured. Not following the recommended placement for the Lower Unit will cause damage to the product and void your product warranty.

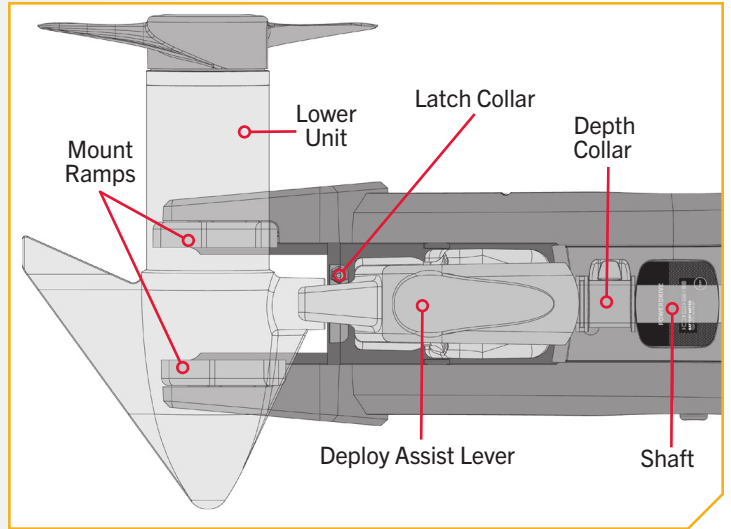

NOTICE: Slide the Depth Collar down and secure it against the top of the Steering Housing when stowed to secure the motor in place and prevent accidental deployment.



WARNING

When the motor is stowed the depth collar must be positioned against the steering housing and tightened in place with the knob to prevent accidental deployment which may result in injury or damage to the trolling motor, accessories or boat.

USING THE FOOT PEDAL

CONTROLLING SPEED & STEERING WITH THE FOOT PEDAL

The foot pedal is used to operate the motor. Controls on the foot pedal are easy to operate by either foot or hand. The motor can also be controlled by a compatible Minn Kota remote if applicable, however, both can not be used simultaneously. Please refer to the literature provided with the compatible remote on how the remote controls the motor. To learn more about accessories that are compatible with the PowerDrive, please visit minnkota.johnsonoutdoors.com.

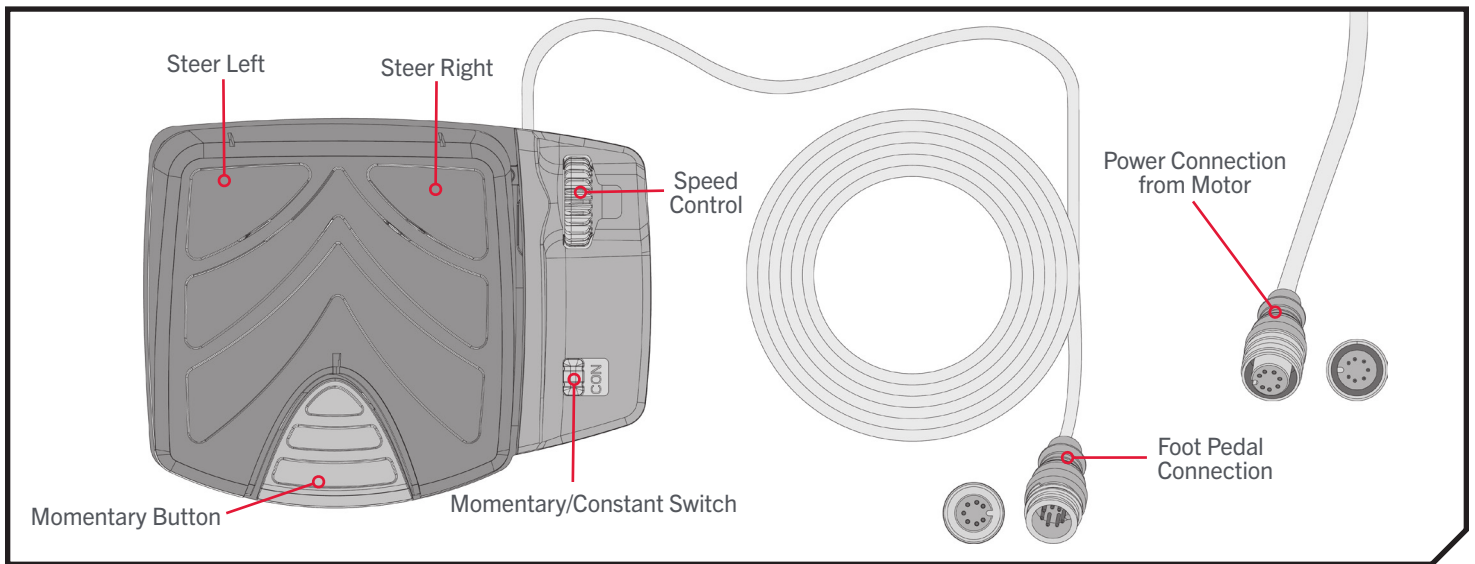

› Momentary Button

The Momentary Button is located at the heel end of the foot pedal and is used to turn the propeller on.

› Momentary/Constant Switch

The Momentary/Constant Switch is used to toggle between Momentary and Constant Mode. During Momentary Mode (MOM), the propeller only turns while pressure is applied to the Momentary Button. While in Constant Mode (CON), the propeller will run continuously regardless of pressure being applied to the Momentary Button.

If a propeller encounters an obstruction while either in Momentary or Constant Mode, while the propeller is running, the increased electrical current being generated by the obstruction will signal the motor to decrease the power to the propeller to prevent damage. If the current overload is detected for more than 20 seconds, the prop will be disabled to prevent damage to the motor. In this event, the operator can turn the prop back on after being sure that the obstruction has been cleared.

› Speed Control

The Speed Control dial is on the upper right side of the toe end of the Foot Pedal. Turn the Speed Knob forward to increase speed and backward to decrease speed. Speed can also be adjusted using the remote, if applicable.

› Steer Right and Steering Left

The main button on the foot pedal is to control steering. Steer Right by applying pressure to the right side of the button and Steer Left by applying pressure to the left side of the button. The position and direction of the Steering Head directly corresponds to the position of the motor. You must use your foot on the pedal to control the steering direction during manual operation. The direction of the motor can also be controlled with the remote.

CAUTION

The steering system is designed to turn your motor 360°. Be careful to avoid over-wrapping the coil cord around the composite shaft. Damage to the coil cord can occur when it is over-wrapped, which will prevent the motor from operating correctly.

CONTROLLING SPEED & STEERING WITH THE FOOT PEDAL

› Steering in Reverse

The propeller always turns in the forward direction. You can reverse the direction of thrust by turning the motor 180°.

NOTICE: The motor will not auto correct to drive straight.

WARNING

You are responsible for the safe and prudent operation of your vessel. We have designed PowerDrive to be an accurate and reliable tool that will enhance boat operation and improve your ability to catch fish. This product does not relieve you from the responsibility for safe operation of your boat. You must avoid hazards to navigation and always maintain a permanent watch so you can respond to situations as they develop. You must always be prepared to regain manual control of your boat. Learn to operate your PowerDrive in an area free from hazards and obstacles.

CAUTION

For safety reasons, disconnect the motor from the battery/batteries when the motor is not in use or while the battery/batteries are being charged. If the motor control is left on and the propeller rotation is blocked, severe motor damage can result.

WARNING

Practice proper ergonomics when operating the foot pedal to prevent injury.

SERVICE & MAINTENANCE

PROPELLER REPLACEMENT

TOOLS AND RESOURCES REQUIRED >

- 9/16" Open End Wrench
- Flat Blade Screwdriver

INSTALLATION >

- 1**
- Disconnect the motor from all sources of power prior to changing the propeller.
 - Hold the propeller and loosen the Prop Nut with a pliers or a wrench.
 - Remove the Prop Nut and Prop Washer.

NOTICE: If the Drive Pin is sheared or broken, you will need to hold the shaft stationary with a flat blade screwdriver pressed into the slot on the end of the shaft while you loosen the Prop Nut.

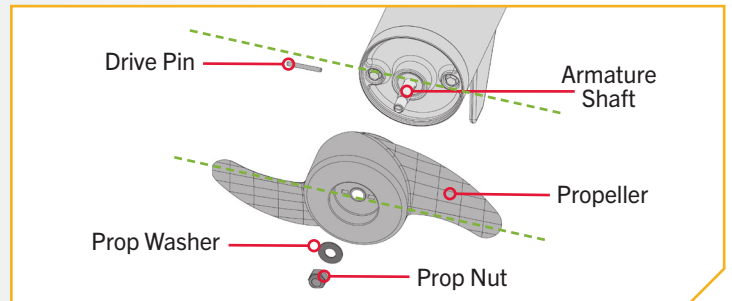

CAUTION

Disconnect the motor from the battery before beginning any prop work or maintenance.

- 2**
- Turn the old prop to horizontal and pull it straight off. If drive pin falls out, push it back in.

CAUTION

If the prop does not readily slide off, take care not to bend the Armature Shaft while removing the prop by pulling the prop evenly off the Armature Shaft.

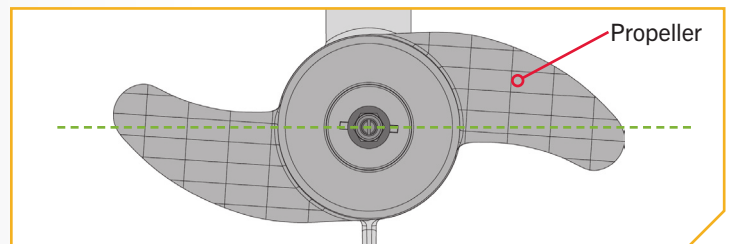

- 3**
- Align the new Propeller with the Drive Pin.
 - Install the Prop Washer and Prop Nut.
 - Tighten the Prop Nut 1/4 turn past snug at 25-35 inch-lbs.

CAUTION

Do not over tighten as this can damage the prop.

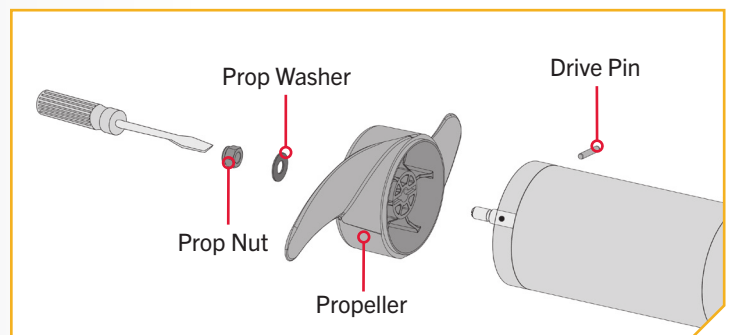

GENERAL MAINTENANCE

- After use, the entire motor should be rinsed with freshwater. This series of motors is not equipped for saltwater exposure.
- The composite shaft requires periodic cleaning and lubrication for proper retraction and deployment. A coating of an aqueous based silicone spray will improve operation.
- The propeller must be inspected and cleaned from weeds and fishing line after every use.
- Fishing line and weeds can get behind the prop, damage the seals and allow water to enter the motor.
- Verify the prop nut is secure each time the motor is used.
- To prevent accidental damage during transportation or storage, disconnect the battery whenever the motor is off of the water. For prolonged storage, lightly coat all metal parts with an aqueous based silicone spray.
- For maximum battery life recharge the battery(s) as soon as possible after use. For maximum motor performance restore battery to full charge prior to use.
- Keep battery terminals clean with fine sandpaper or emery cloth.
- The propeller is designed to provide weed free operation with very high efficiency. To maintain this top performance, the leading edge of the blades must be kept smooth. If they are rough or nicked from use, restore to smooth by sanding with fine sandpaper.
- Stow the motor after each use to allow water to drain from the steering housing. Water that sits in the steering housing when the motor is not in use may cause damage.

TROUBLESHOOTING

1. Motor fails to run or lacks power:
 - Check battery connections for proper polarity.
 - Make sure terminals are clean and corrosion free. Use fine sandpaper or emery cloth to clean terminals.
 - Check battery water level. Add water if needed.
2. Motor loses power after a short running time:
 - Check battery charge. If low, restore to full charge.
3. You experience prop vibration during normal operation:
 - Remove and rotate the prop 180°. See removal instructions in the Propeller Replacement Section.
4. Experiencing interference with your fish finder:
 - You may, in some applications, experience interference in your depth finder display. We recommend that you use a separate deep cycle marine battery for your trolling motor and that you power the depth finder from the starting/cranking battery. If problems still persist, call our service department at 1-800-227-6433.

NOTICE: For all other malfunctions, visit an Authorized Service Center. You can search for an Authorized Service Center in your area by visiting minnkota.johnsonoutdoors.com, or by calling our customer service number at 800-227-6433.

FOR FURTHER TROUBLESHOOTING AND REPAIR



FOR FURTHER TROUBLESHOOTING AND REPAIR

We offer several options to help you troubleshoot and/or repair your product. Please read through the options listed below.



Buy Parts Online

You can buy parts on-line directly from our website at minnkota.johnsonoutdoors.com. From screws to sideplates, you can order replacement parts for your Minn Kota products.



Frequently Asked Questions

Find answers to general inquiries, battery and rigging installation, and networking scenarios. We have FAQs available on our website at minnkota.johnsonoutdoors.com to help answer all of your Minn Kota questions.



Call Us (for U.S. and Canada)

Our consumer service representatives are available Monday – Friday between 7:00 a.m. – 4:30 p.m. CST at 800-227-6433. If you are calling to order parts, please have the 11-character serial number from your product, specific part numbers, and credit card information available. This will help expedite your call and allow us to provide you with the best consumer service possible. You can reference the parts list located in your manual to identify the specific part numbers.



Contact Us

You can contact our consumer service department with questions regarding your Minn Kota products. To inquire, visit minnkota.johnsonoutdoors.com.



Authorized Service Centers

Minn Kota has over 800 authorized service centers in the United States and Canada where you can purchase parts or get your products repaired. Please visit our website to locate a service center in your area.



Scan to visit
Minn Kota
service online.



COMPLIANCE STATEMENTS

ENVIRONMENTAL COMPLIANCE STATEMENT

It is the intention of JOME to be a responsible corporate citizen, operating in compliance with known and applicable environmental regulations, and a good neighbor in the communities where we make or sell our products.

WEEE DIRECTIVE

EU Directive 2002/96/EC “Waste of Electrical and Electronic Equipment Directive (WEEE)” impacts most distributors, sellers, and manufacturers of consumer electronics in the European Union. The WEEE Directive requires the producer of consumer electronics to take responsibility for the management of waste from their products to achieve environmentally responsible disposal during the product life cycle.

WEEE compliance may not be required in your location for electrical & electronic equipment (EEE), nor may it be required for EEE designed and intended as fixed or temporary installation in transportation vehicles such as automobiles, aircraft, and boats. In some European Union member states, these vehicles are considered outside of the scope of the Directive, and EEE for those applications can be considered excluded from the WEEE Directive requirement.

This symbol (WEEE wheelee bin) on product indicates the product must not be disposed of with other household refuse. It must be disposed of and collected for recycling and recovery of waste EEE. Johnson Outdoors Inc. will mark all EEE products in accordance with the WEEE Directive. It is our goal to comply in the collection, treatment, recovery, and environmentally sound disposal of those products; however, these requirements do vary within European Union member states. For more information about where you should dispose of your waste equipment for recycling and recovery and/or your European Union member state requirements, please contact your dealer or distributor from which your product was purchased.



DISPOSAL

Minn Kota motors are not subject to the disposal regulations EAG-VO (electric devices directive) that implements the WEEE directive. Nevertheless never dispose of your Minn Kota motor in a garbage bin but at the proper place of collection of your local town council.

Never dispose of battery in a garbage bin. Comply with the disposal directions of the manufacturer or his representative and dispose of them at the proper place of collection of your local town council.

REGULATORY COMPLIANCE INFORMATION

› Advanced GPS Navigation

For regulatory information on motors that come factory installed with Advanced GPS Navigation, please refer to the Advanced GPS Navigation Owner's Manual on-line at minnkota.johnsonoutdoors.com.

FCC COMPLIANCE



FCC COMPLIANCE

This device complies with Part 15 of the FCC rules. **Operation is subject to the following two conditions:**

1. This device may not cause harmful interference.
2. This device must accept any interference that may be received, including interference that may cause undesired operation.

Changes or modifications not expressly approved by Johnson Outdoors Marine Electronics, Inc. could void the user’s authority to operate this equipment.

NOTICE: This equipment has been tested and found to comply with the limits for a Class B digital device, pursuant to part 15 of the FCC Rules. These limits are designed to provide reasonable protection against harmful interference in a residential installation. This equipment generates, uses and can radiate radio frequency energy and, if not installed and used in accordance with the instructions, may cause harmful interference to radio communications. However, there is no guarantee that interference will not occur in a particular installation. **If this equipment does cause harmful interference to radio or television reception, which can be determined by turning the equipment off and on, the user is encouraged to try to correct the interference by one or more of the following measures:**

- Reorient or relocate the receiving antenna.
- Increase the separation between the equipment and receiver.
- Connect the equipment into an outlet on a circuit different from that to which the receiver is connected.
- Consult the dealer or an experienced radio/TV technician for help.

INDUSTRY CANADA COMPLIANCE

This product meets the applicable Industry Canada technical specifications. Operation is subject to the following two conditions: (1) this device may not cause interference, and (2) this device must accept any interference, including interference that may cause undesired operation of the device.

ENVIRONMENTAL RATINGS

- Ambient operating temperature range: -10C to 50C
- Ambient operating humidity range: 5% to 95%
- Maximum operating altitude: 10,000 feet



PARTS DIAGRAM & PARTS LIST

POWERDRIVE - 42/45/50/55/70 LBS THRUST - 12/24 VOLT - 48"/54"/60" SHAFT

The parts diagram and parts list provides Minn Kota® WEEE compliance disassembly instructions. For more information about where you should dispose of your waste equipment for recycling and recovery and/or your European Union member state requirements, please contact your dealer or distributor from which your product was purchased. Tools required, but not limited to: flat head screwdriver, Phillips screwdriver, socket set, pliers, wire cutters.

POWERDRIVE CONTROL HEAD >

> Control Head Parts Diagram

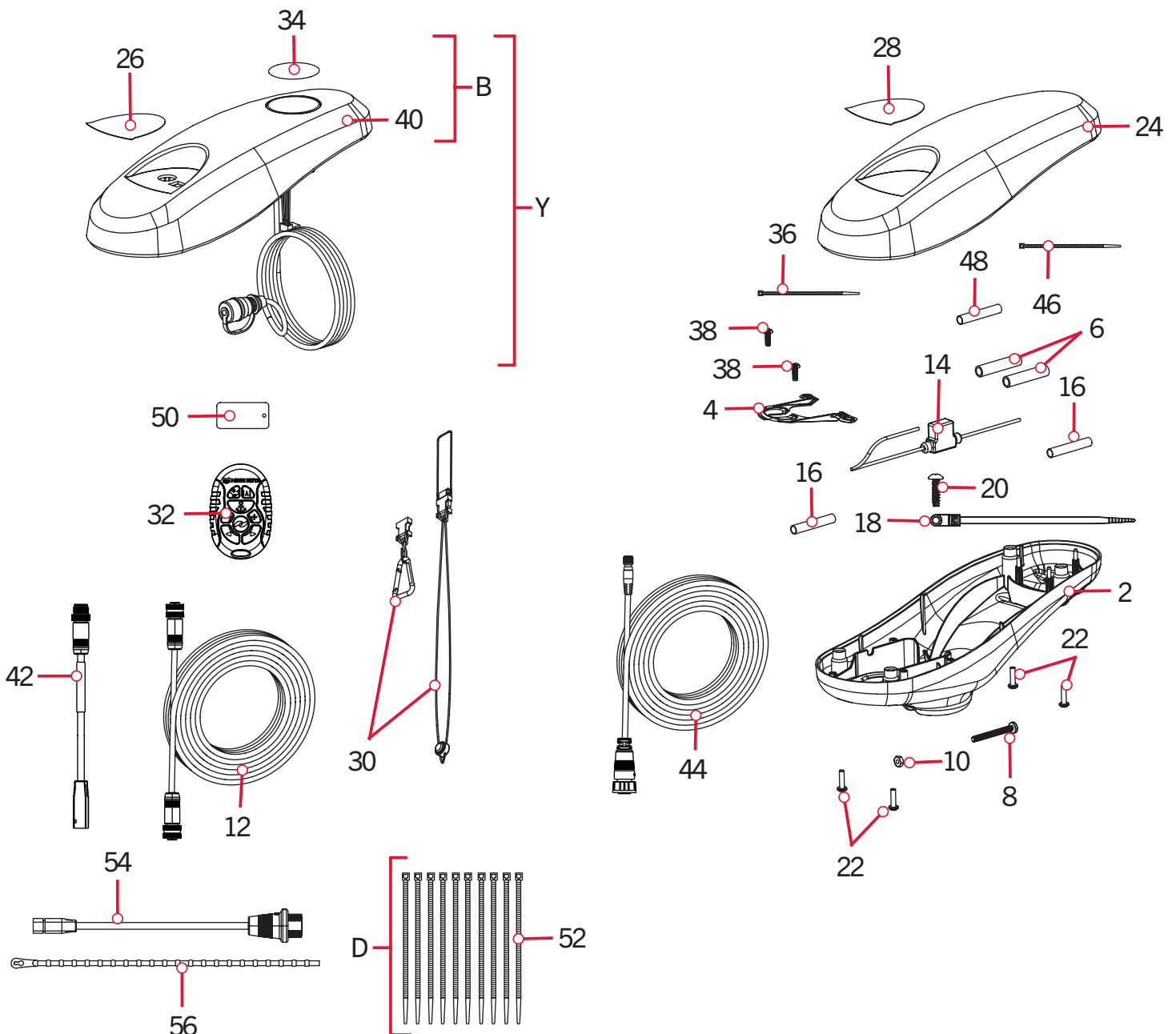

PARTS DIAGRAM & PARTS LIST

Control Head Parts List

Assembly	Part #	Description	Notes	Quantity
B	2770242	COV KIT, ADV GPS NAV, TRV/UTX	*COVER & DECALS ONLY* *GPS*	1
Y	2774108	CONTROLLER, ADV GPS NAV, PD	*GPS*	1
D	2996300	TIE WRAP ASM, 60"	*GPS*	1
Item	Part #	Description	Notes	Quantity
2	2292505	CONTROL BOX		1
4	2224706	PLUG, SCREW-DOWN, BLK		1
6	2065400	WIRE INSULATOR-LGE 1-3/4,BLUE		2
8	2383407	SCREW-#10-24 X 2" PPH ZINC		1
10	2013110	NUT-HEX #10-24 UNC-2B (ZCP)		1
12	490384-4	CABLE, ETHERNET (M12-M12) 30'	*GPS*	1
14	2218201	FUSE HOLDER ASSEMBLY	*55LB* *70LB*	1
16	2375400	SHRINK TUBE-1/4OD X 1-3/4		2
18	2206302	TIE WRAP, SCREW MOUNT 6.3"	*DSC* *GPS*	1
20	2203441	SCREW-#6 X 1/2" THRD FORM,SSTL	*DSC* *GPS*	1
22	2372100	SCREW-#8-18 X 5/8 THD (SS)	*GPS*	4
	2012100	SCREW-#8-18 X 5/8 THD CUT Z/P	*NON GPS*	4
24	2290217	CVR, CTRL BOX, V3 PRINTED	*NON GPS*	1
26	2395577	DECAL, PUSH BUTTON TOP, 70 lb, PD, FW	*70LB THRUST* *GPS*	1
	2395576	DECAL, PUSH BUTTON TOP, 55 lb, PD, FW	*55LB THRUST* *GPS*	1
	2395575	DECAL, PUSH BUTTON TOP, 45 lb, PD, FW	*45LB THRUST* *GPS*	1
28	2395549	DECAL,CTRL DECAL TOP, 70 lb, PD, FW	*70LB THRUST*	1
	2395559	DECAL, CTRL DECAL TOP, 50 lb, PD, FW	*50LB THRUST*	1
	2395557	DECAL, CTRL DECAL TOP, 55 lb, PD, FW	*55LB THRUST*	1
	2395556	DECAL, CTRL DECAL TOP, 45 lb, PD, FW	*45LB THRUST*	1
	2395558	DECAL, CTRL DECAL TOP, 42 lb, PD, FW	*42LB THRUST*	1
30	2390802	LANYARD W/CARABINR, IP RMT	*GPS*	1
32	2994175	REMOTE ASM, MICRO REMOTE	*GPS*	1
34	2395524	DECAL,DOMED iP LNK 4.0 FW	*GPS*	1
▲	2317126	INSTRC-INSTALL, POWERDRIVE FW		1
▲	2297165	MANUAL-DISCLAIMER,DWNLOAD INFO		1
▲	2317124	MANUAL, POWERDRIVE FW		1
▲	2394910	INSTRC. SHEET, MICRO REMO	*GPS*	1
▲	2394912	QCK REF.GUIDE, iP MICRO RMT BT	*GPS*	1
36	2256300	TIE WRAP-5.5" BLACK	*DSC* *GPS* *DSC GPS*	1
38	2372103	SCREW-#6 X .375 PLASTITE SS		2

▲ Not shown on Parts Diagram.

* This part is included in an assembly and cannot be ordered individually.

PARTS DIAGRAM & PARTS LIST



Item	Part #	Description	Notes	Quantity
40	✘	COVER,CTRL BOX iP, PD PRINTED	*GPS* *SEE ASSEMBLY B*	1
42	490384-4	CABLE, ETHERNET (M12-M12) 30'	*GPS*	1
44	490575-3	CABLE ADPTR, 14 PIN, 110" - DSC	*DSC*	1
46	2206301	TIE WRAP LOW PROFILE 8"	*GPS*	1
48	2325401	SHRINK TUBE-3/4 ID X 2" W ADHS		1
50	2394110	TAG, MICRO REMOTE		1
52	2206300	TIE WRAP, LOW PROFILE 4"		10
▲	2294950	OBN & REMOTE PAIR INSTRUCT		1
54	2994961	BAG ASM, CABLE ADPT, 490537-2	*490537-2* *MKR-MI-1*	1
▲	2207131	STANDARD QS SETUP GUIDE		1
56	2206304	TIE WRAP, REUSABLE		1

▲ Not shown on Parts Diagram.

✘ This part is included in an assembly and cannot be ordered individually.



PARTS DIAGRAM & PARTS LIST

POWERDRIVE MOTOR >

> 12 Volt 3.25" 42/45lb Thrust Motor Parts Diagram

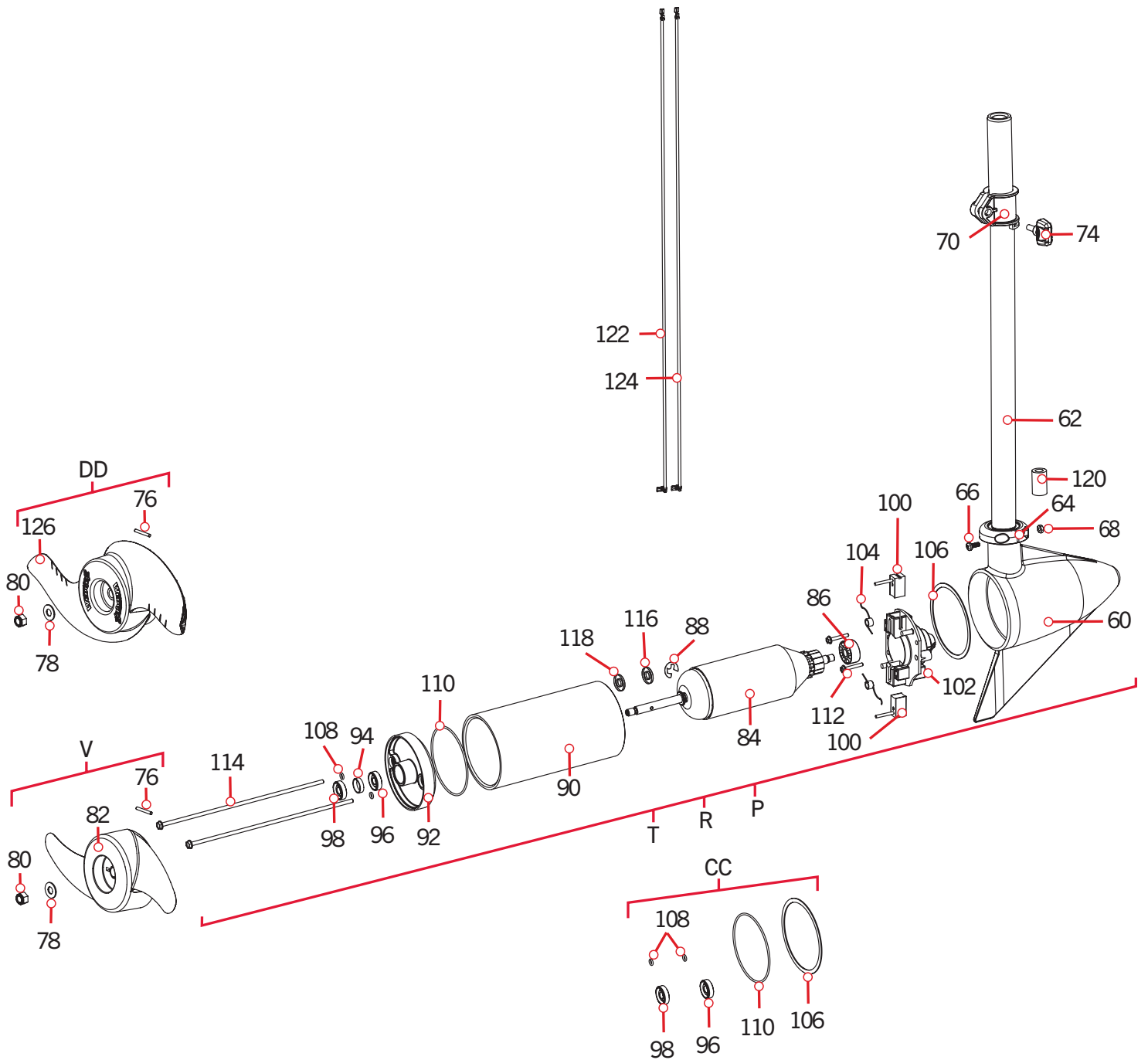

PARTS DIAGRAM & PARTS LIST

▶ 12 Volt 3.25" 42/45lb Thrust Motor Parts List

Assembly	Part #	Description	Notes	Quantity
P	2069289	MTR ASY 12V 3.25 VS FW 45# BB	*45LB 54"	1
R	2069283	MTR ASY 12V 3.25 VS FW 45	*45LB 48"	1
T	2069233	MTR ASY 12V 3.25 VS FW 42# BB	*42LB 54"	1
V	1378121	PROP IND 2061122 (PWR PROP)		1
CC	2883460	SEAL & O-RING KIT		1
DD	1378126	PROP IND 2061125 WDL5 WDG	*NOT INCLUDED FROM THE FACTORY*	1
Item	Part #	Description	Notes	Quantity
60	421-132	HSG BRUSH END 3.25		1
62	2032076	TUBE COMPOSITE 54" PD/AP	*42LB 54" *45LB 54"	1
	2032075	TUBE COMPOSITE 48" PD/AP	*45LB 48"	1
64	2301555	COLLAR-LATCH, PD/AP		1
66	2303434	SCREW-#8-32 X 5/8 MACH PHCR SS		1
68	2303112	NUT-#8-32 NYLOCK SS		1
70	2031522	COLLAR DRIVE (W/INSERT)		1
74	2011365	SCREW-COLLAR/NEW KNOB		1
76	2092600	PIN-DRIVE 1.06" LG (SS)		1
78	2151726	WASHER-5/16 STD (S/S)		1
80	2053101	NUT-PROP,NYLOC (MED) 5/16 SS		1
82	2061122	PROP-POWER (3.25")		1
84	2-100-202	ARMATURE AS SY 12V 3.25		1
86	140-010	BALL BEARING		1
88	788-015	RETAINING RING	*3.25*	1
90	2-200-079	CTR HSG ASY 3.25 TX-MAGNT		1
92	2-400-128	PLAIN END HSG ASY 3.25		1
94	144-049	BEARING - FLANGE (SERVICE ONLY)		1
96	880-003	SEAL		1
98	880-006	SEAL WITH SHIELD		1
100	188-052	BRUSH ASSEMBLY 3.25		2
102	738-030	BRUSH PLATE 3.25		1
104	975-032	SPRING - COMPRESSION 3.25		2
106	701-041	O-RING MEDIUM 3.25		1
108	701-007	O-RING	*THRU BOLT*	2
110	701-039	O-RING SMALL 3.25		1
112	830-001	SCREW-#8-32x1.75 SELF-THRD		2
114	830-078	THRU BOLT 8-32 X 8.96		2

▲ Not shown on Parts Diagram.

✘ This part is included in an assembly and cannot be ordered individually.

PARTS DIAGRAM & PARTS LIST



Item	Part #	Description		Quantity
116	990-067	WASHER - STEEL THRUST		1
118	990-070	WASHER - NYLATRON		1
120	2307314	BEAD-FERRITE	*45LB 54"*	1
122	640-104M	LEADWIRE RED 10AWG 48"	*42LB 54"* *45LB 48"*	1
	640-107M	LEADWIRE RED 10A 65 1/2	*45LB 54"*	1
124	640-003M	LEADWIRE BLK 10AWG 48"	*42LB 54"* *45LB 48"*	1
	640-008M	LEADWIRE BLK 10A 63 1/2	*45LB 54"*	1
126	2061125	PROP (65 WEEDLESS WEDGE)	*NOT INCLUDED FROM THE FACTORY*	1

▲ Not shown on Parts Diagram.

✘ This part is included in an assembly and cannot be ordered individually.



PARTS DIAGRAM & PARTS LIST

12 Volt 3.625" 50/55lb Motor Parts Diagram

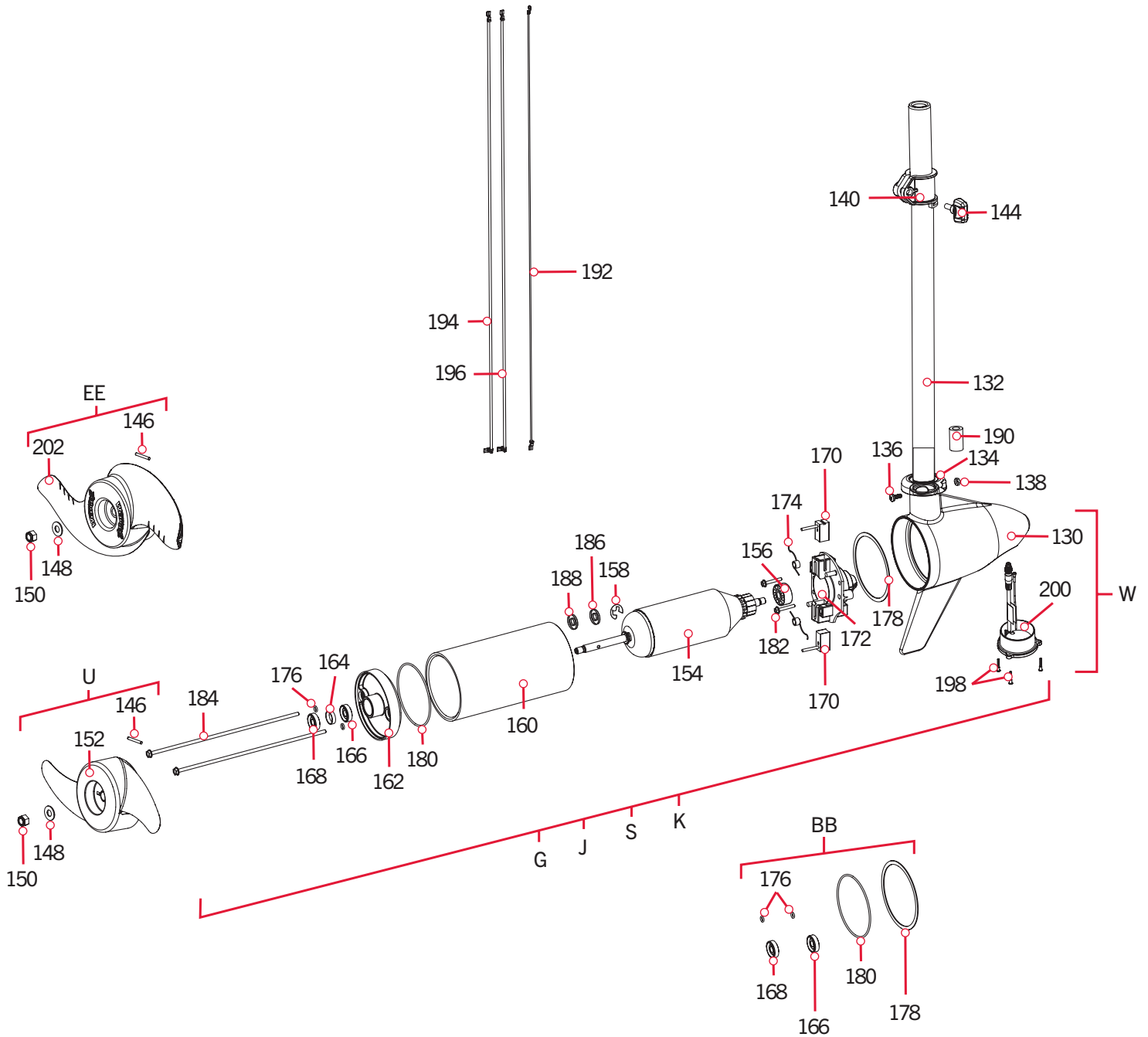

PARTS DIAGRAM & PARTS LIST

› 12 Volt 3.625" 50/55lb Motor Parts List

Assembly	Part #	Description	Notes	Quantity
J	2097090	MTR ASY 12V 3.62 VS FW 55#	*55LB 54"*	1
K	2437090	MTR ASY 12V 3.62 55#	*55LB 54"* *DSC*	1
S	2097034	MTR ASY 12V 3.62 VS 50#	*50LB 54"*	1
G	2097072	MTR ASY 12V 3.62 VS FW 55#	*55LB 48" PONTOON*	1
U	1378170	PROP KIT 2091170 PWR PRP		1
EE	1378131	PROP IND 2091160 (WDL5 WDGII)	*NOT INCLUDED FROM THE FACTORY*	1
W	2993081	PLN END HSG/TRDC 3.62 DSC	*DSC* *54"*	1
BB	2888460	SEAL & O-RING KIT		1
Item	Part #	Description	Notes	Quantity
130	421-065	HSG BRUSH END 3.625		1
	✘	BRUSH END HSG 3.625,US2.5	*DSC*	1
132	2032076	TUBE COMPOSITE 54" PD/AP		1
	2302075	TUBE COMPOSITE 48" PD/AP 2001	*55LB 48" PONTOON*	1
134	2301555	COLLAR-LATCH, PD/AP		1
136	2303434	SCREW-#8-32 X 5/8 MACH PHCR SS		1
138	2303112	NUT-#8-32 NYLOCK SS		1
140	2031522	COLLAR DRIVE (W/INSERT)		1
144	2011365	SCREW-COLLAR/NEW KNOB		1
146	2092600	PIN-DRIVE 1.06" LG (SS)		1
148	2151726	WASHER-5/16 STD (S/S)		1
150	2053101	NUT-PROP,NYLOC (MED) 5/16 SS		1
152	2091170	PROP-PRW (3 5/8") REAMED		1
154	92-100-121	ARM ASY 12V 3.62 55#2.88"		1
156	140-010	BALL BEARING		1
158	788-015	RETAINING RING		1
160	92-200-101	CTR HSG ASY 3.625 TX-MGNTZ		1
162	92-400-101	PLAIN END HSG ASY 3.625		1
164	144-049	BEARING - FLANGE	*SERVICE ONLY*	1
166	880-003	SEAL		1
168	880-006	SEAL WITH SHIELD		1
170	188-036	BRUSH ASSEMBLY 3.625		2
172	738-036	BRUSH PLATE 3.625		1
174	975-040	SPRING - TORSION 3.625		2
176	701-008	THRU BOLT O-RING		2
178	337-036	GASKET		1

▲ Not shown on Parts Diagram.

✘ This part is included in an assembly and cannot be ordered individually.

PARTS DIAGRAM & PARTS LIST



Item	Part #	Description		Quantity
180	701-081	O-RING		1
182	830-007	SCREW, # 8-32		2
184	830-042	THRU BOLT 10-32 X 8.83		2
186	990-067	WASHER - STEEL THRUST		1
188	990-070	WASHER - NYLATRON		1
190	2307314	BEAD-FERRITE 50LB	*50LB 54"*	1
	2307317	FERRITE BEAD, SHORT	*55LB 54"*	1
192	640-315	LEADWIRE BROWN 18 AWG 62" GPT	*DSC*	1
194	640-107	LEADWIRE RED 10AWG 65-1/2" GPT 55LB	*55LB 54"*	1
	640-109	LEADWIRE RED 10 AWG 72 GPT 50LB	*50LB 54"*	1
	640-105M	LEADWIRE RED 10AWG 58 GPT	*55LB 48" PONTOON*	1
196	640-008	LEADWIRE BLK 10AWG 63-1/2" GPT 55LB	*55LB 54"*	1
	640-010	LEADWIRE BLK 10 AWG 70 GPT 50LB	*50LB 54"*	1
	640-004M	LEADWIRE BLK 10 AWG 56 GPT	*55LB 48" PONTOON*	1
198	✘	SCREW-#6-32X1/2"TORX PH SS	*DSC*	3
200	✘	XCSC XDUCER ASSY 67" HWT	*DSC*	1
202	2091160	PROP-WW2 (3.625") REAMED	*NOT INCLUDED FROM THE FACTORY*	1

▲ Not shown on Parts Diagram.

✘ This part is included in an assembly and cannot be ordered individually.



PARTS DIAGRAM & PARTS LIST

24 Volt 3.625" 70lb Motor Parts Diagram

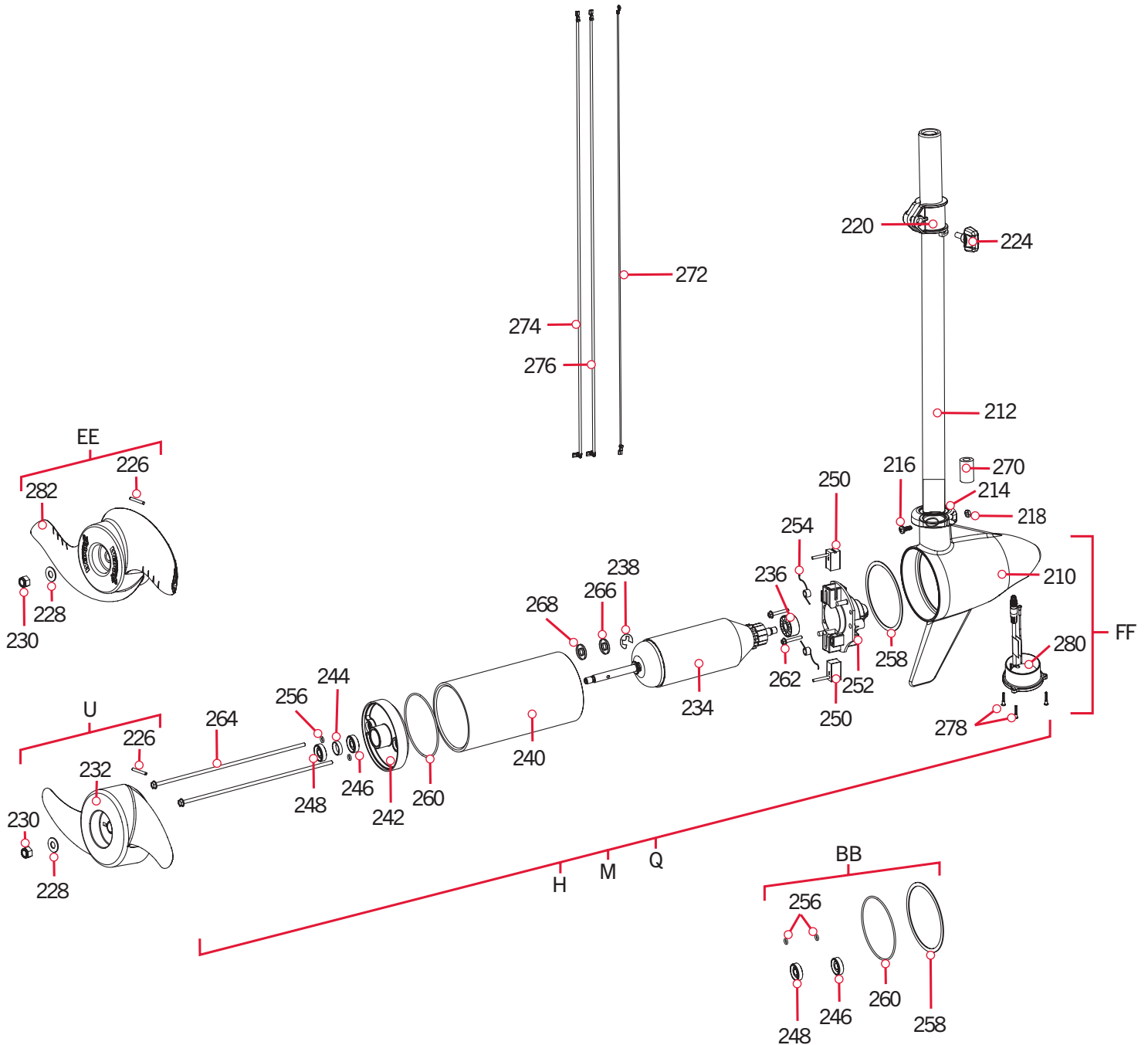

PARTS DIAGRAM & PARTS LIST

▶ 24 Volt 3.625" 70lb Motor Parts List

Assembly	Part #	Description		Quantity
H	2437095	MTR ASY 24V 3.62" 70# DSC	*70LB 60" DSC* *70LB 60" DSC GPS*	1
Q	2096067	MTR ASY 24V 3.62 VS 70# FW	*70LB 48" PONTOON*	1
M	2886032	MTR ASY 24V 3.62 VS 70#FW	*70LB 54" GPS* *70LB 60"	1
FF	2993082	PLN END HSG/TRDC 3.62 DSC	*DSC* *60"	1
U	1378170	PROP KIT 2091170 PWR PRP		1
EE	1378131	PROP IND 2091160 (WDLS WDGII)	*NOT INCLUDED FROM THE FACTORY*	1
BB	2888460	SEAL & O-RING KIT		1
Item	Part #	Description		Quantity
210	✘	BRUSH END HSG 3.625,US2.5	*DSC*	1
	421-065	HSG BRUSH END 3.625		1
212	2032074	TUBE COMPOSITE 60" PD/AP	*60"	1
	2032076	TUBE COMPOSITE 54" PD/AP	*54"	1
	2032075	TUBE COMPOSITE 48" PD/AP 2001	*70LB 48" PONTOON*	1
214	2301555	COLLAR-LATCH, PD/AP		1
216	2303434	SCREW-#8-32 X 5/8 MACH PHCR SS		1
218	2303112	NUT-#8-32 NYLOCK SS		1
220	2031522	COLLAR DRIVE (W/INSERT)		1
224	2011365	SCREW-COLLAR/NEW KNOB		1
226	2092600	PIN-DRIVE 1.06" LG (SS)		1
228	2151726	WASHER-5/16 STD (S/S)		1
230	2053101	NUT-PROP,NYLOC (MED) 5/16 SS		1
232	2091170	PROP-PWR (3 5/8") REAMED		1
234	92-100-128	ARMATURE ASM 24V 3.62",70		1
236	140-010	BALL BEARING		1
238	788-015	RETAINING RING	*3.625*	1
240	92-200-005	CTR HSG ASY 3.625 FW-MAGNET		1
242	92-400-101	PLAIN END HSG ASY 3.625		1
244	144-049	BEARING - FLANGE	*SERVICE ONLY*	1
246	880-003	SEAL		1
248	880-006	SEAL WITH SHIELD		1
250	188-038	BRUSH ASSEMBLY 3.625		2
252	738-038	BRUSH PLATE, 3.625", 70#		1
254	975-042	SPRING-TORSION, 70# LOWER UNIT		2
256	701-008	THRU BOLT O-RING		2
258	337-036	GASKET		1

▲ Not shown on Parts Diagram.

✘ This part is included in an assembly and cannot be ordered individually.

PARTS DIAGRAM & PARTS LIST



Item	Part #	Description		Quantity
260	701-081	O-RING		1
262	830-007	SCREW, # 8-32		2
264	830-008	THRU BOLT 10-32 x 9.205		2
266	990-067	WASHER - STEEL THRUST		1
268	990-070	WASHER - NYLATRON		1
270	2307314	BEAD-FERRITE	*70LB 54"*	1
272	640-316	LEADWIRE BROWN 18 AWG 71" GPT	*70LB 60"*	1
	640-315	LEADWIRE BROWN 18 AWG 62" GPT	*70LB 54"* *70LB 48" PONTOON*	1
274	640-106	LEADWIRE RED 10 AWG 64 GPT	*70LB 54"*	1
	640-109	LEADWIRE RED 10AWG	*70LB 60"*	1
	640-105	LEADWIRE RED 10 AAWG 58 GPT	*70LB 48" PONTOON*	1
276	640-008	LEADWIRE BLK 10AWG 63-1/2" GPT	*70LB 54"*	1
	640-010	LEADWIRE BLK 10 AWG 70 GPT	*70LB 60"*	1
	640-005	LEADWIRE BLK 10 AWG 75 GPT	*70LB 48" PONTOON*	1
278	✘	SCREW-#6-32X1/2"TORX PH SS	*DSC*	3
280	✘	DSC XDUCER ASSY 73" HW T	*DSC*	1
282	2091160	PROP-WW2 (3.625") REAMED	*NOT INCLUDED FROM THE FACTORY*	1

▲ Not shown on Parts Diagram.

✘ This part is included in an assembly and cannot be ordered individually.



POWERDRIVE STEERING HOUSING >

> Steering Housing Parts Diagram

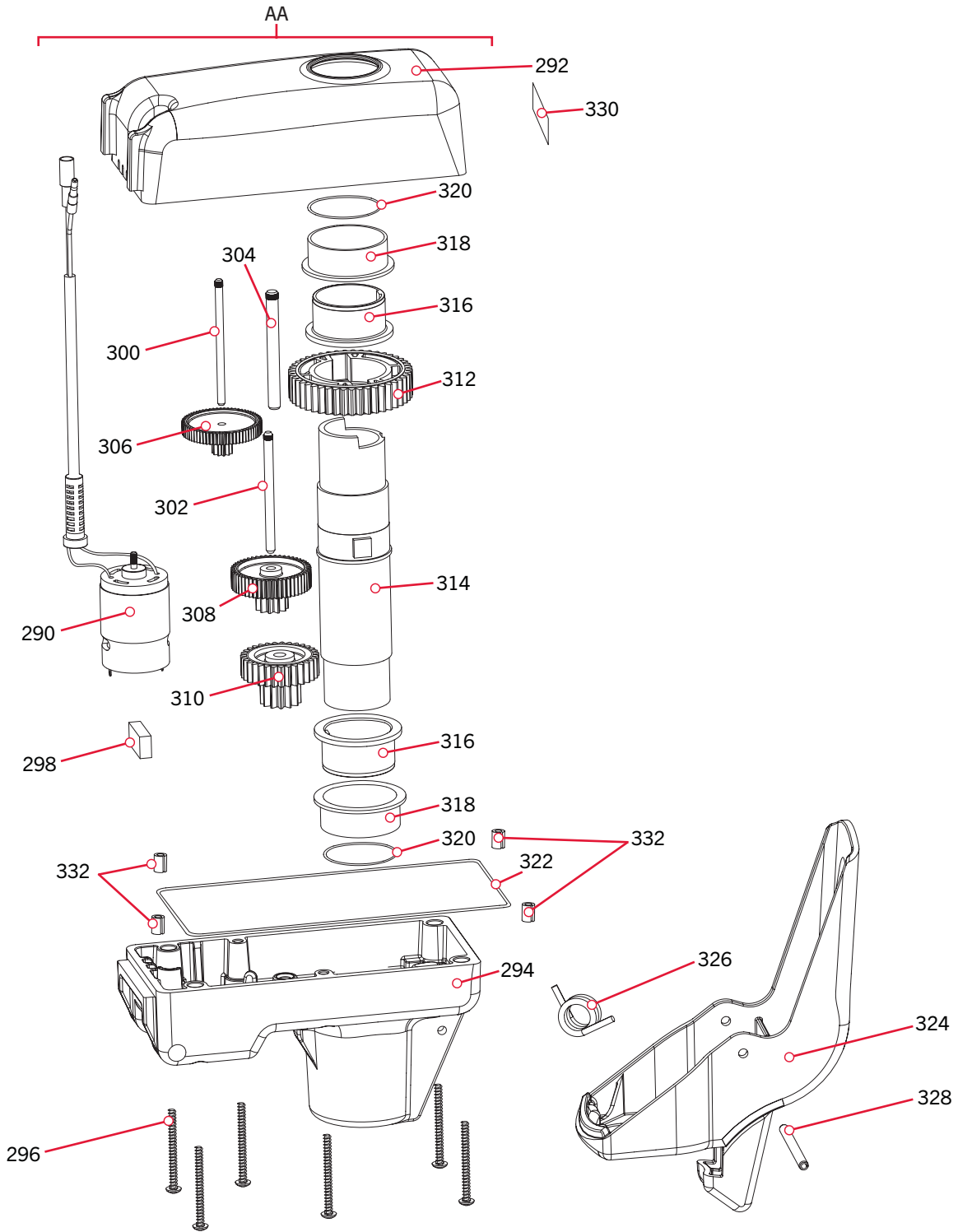

PARTS DIAGRAM & PARTS LIST

› Steering Housing Parts List

Assembly	Part #	Description	Notes	Quantity
AA	2991836	DRIVE HOUSING ASSY, PD		1
Item	Part #	Description	Notes	Quantity
290	2777050	MOTOR DR.HSG PD/AP 12,24V		1
292	2302541	CASE-UPPER,ALUM,FW,PAINTED		1
294	2302561	CASE-LOWER, ALUM, FW, PAINTED		1
296	2303408	SCREW-#8-32 TYPE F TORX PH SS		6
298	2308601	BREATHER FILTER, DR.HOUSING		1
300	2302610	SHAFT-GEAR, FIRST CLUSTER		1
302	2302615	SHAFT-GEAR,INTERMED.CLUSTER		1
304	2302620	SHAFT-GEAR, THIRD CLUSTER		1
306	2302245	GEAR & PINION,DR. HSG, STAGE 2		1
308	2302250	GEAR & PINION,DR. HSG, STAGE 3		1
310	2302255	GEAR & PINION,DR. HSG, STAGE 4		1
312	2302260	GEAR-OUTPUT SHAFT,STG 5		1
314	2302010	SHAFT-OUTPUT, DR.HOUSING		1
316	2307304	BUSHING-INNER, UPPER/LOWER		2
318	2307305	BUSHING-OUTER, UPPER/LOWER		2
320	2304603	O-RING-SHAFT SEAL UPPER/LOW		2
322	2304604	O-RING-CASE SEAL		1
324	2307201	LEVER,GRIP GLIDE II		1
326	2302750	SPRING-LATCH,TORSION,PD/AP,S/S		1
328	2302627	PIN-ROLL,3/16 X 2.5" ZP		1
330	2315615	DECAL-STOW/DEPLOY,PWRDRV3		1
332	2302605	PIN-ROLL 5/16" X 1/2"		4

▲ Not shown on Parts Diagram.

✘ This part is included in an assembly and cannot be ordered individually.

POWERDRIVE FOOT PEDAL >

> Foot Pedal Parts Diagram

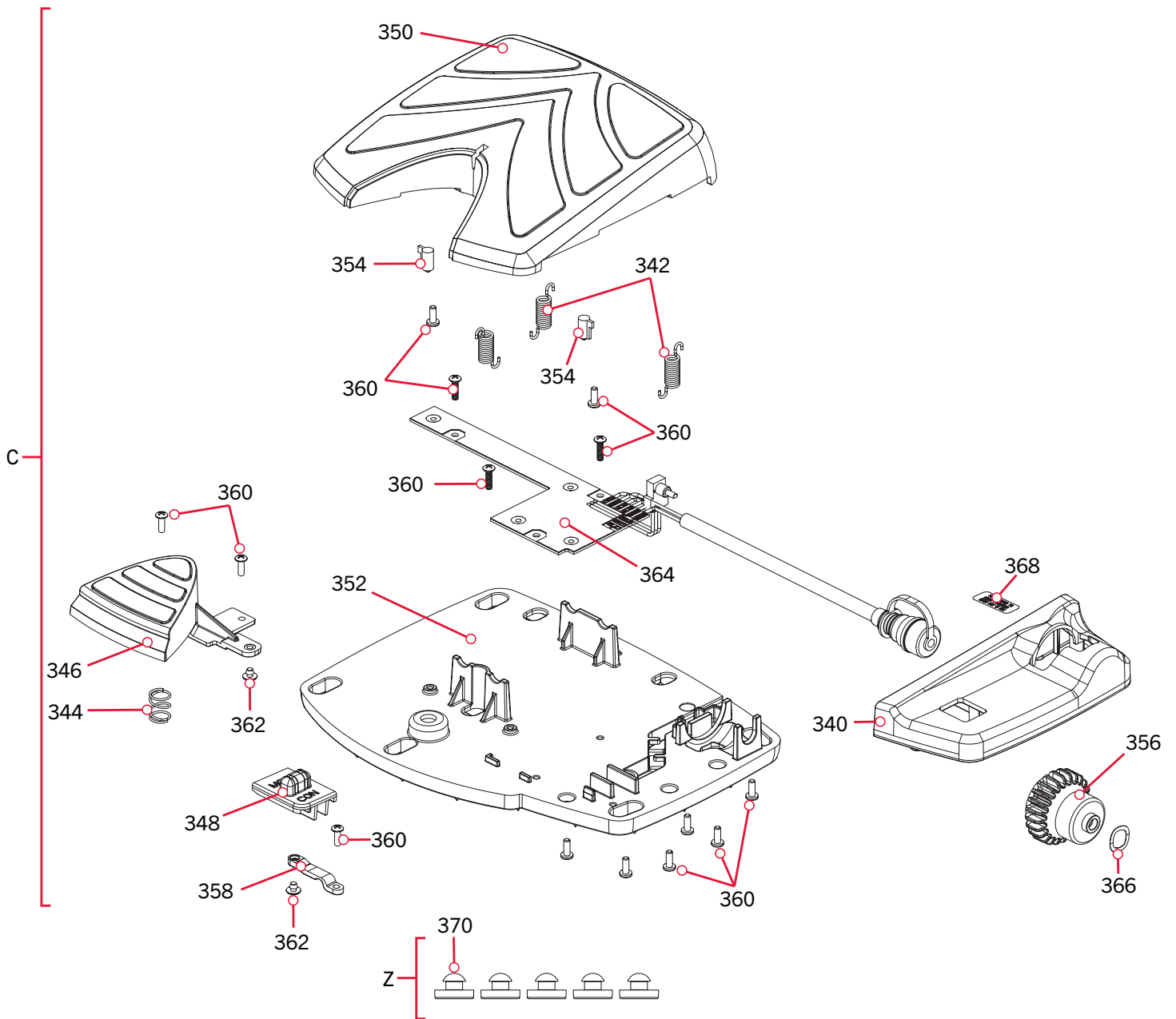

PARTS DIAGRAM & PARTS LIST

Foot Pedal Parts List

Assembly	Part #	Description	Notes	Quantity
C	2994728	FOOT PEDAL ASSEMBLY, PD		1
Z	2994859	BAG ASY-TERROVA/V2,RUB.BUMPERS		1
Item	Part #	Description	Notes	Quantity
340	2300275	COVER-SPEED SELECTOR,PD FP,BLK		1
342	2302730	SPRING-LONG-UPPER PEDAL		3
344	2302732	SPRING-LOWER PEDAL S/S		1
346	2303725	BUTTON-MOMENTARY, PD FP, BLK		1
348	2303730	BUTTON-MOM/CON, PD FP, BLK		1
350	2304406	PEDAL-FOOT, UPPER, POWERDRIVE		1
352	2304508	BASE, PEDAL PD		1
354	2305136	BUMPER,STRG RCKR,PD FP,RUBBER		2
356	2307905	WHEEL-SPEED, PD FP, BLK		1
358	2308609	SWITCH LEVER, SINGLE		1
360	2302105	SCREW #6-19 X 3/8 HIGH-LOW SS		14
362	2335130	BUMBER ACTUATOR		2
364	✘	PCB/CTRL CORD, PD FT PEDAL		1
366	2301750	WASHER, WAVE, PD V3 FP		1
368	2316600	DECAL-ON/OFF SWITCH/PD V2 PED		1
370	2325110	PAD, FOOT PEDAL PD		5

▲ Not shown on Parts Diagram.

✘ This part is included in an assembly and cannot be ordered individually.

PARTS DIAGRAM & PARTS LIST

POWERDRIVE MOUNT >

> Mount Parts Diagram

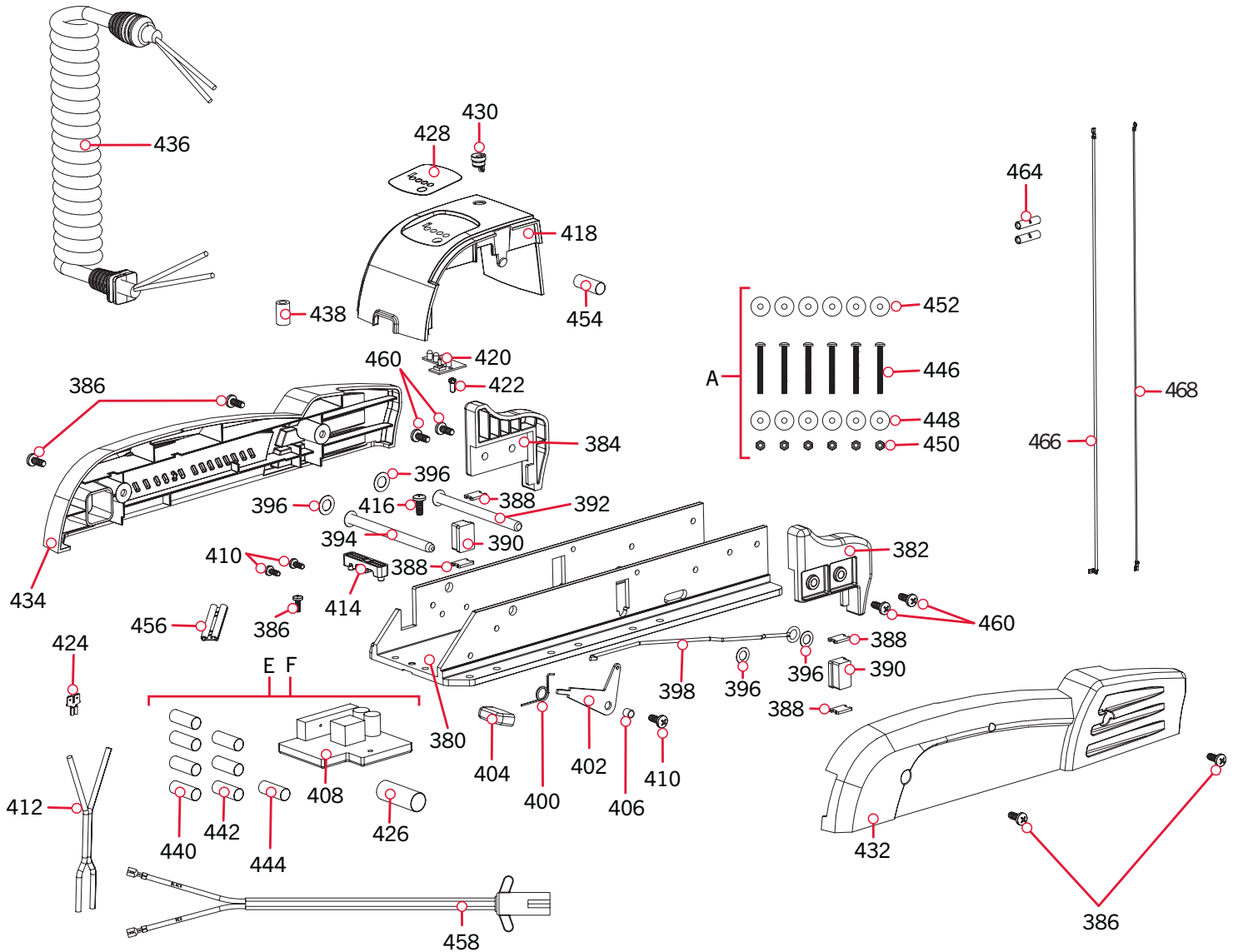

PARTS DIAGRAM & PARTS LIST

Mount Parts List

Assembly	Part #	Description	Notes	Quantity
A	2994864	BAG ASSEMBLY - (BOLT, NUT, WASHERS)		1
E	2884055	CONTROL BRD-12V V2 W/O AP W/SHRNK		1
F	2884056	CONTROL BRD-24V V2 W/O AP W/SHRNK		1
Item	Part #	Description	Notes	Quantity
380	2301936	EXTRUSION BASE PD V2		1
382	2303932	MOTOR REST-RIGHT, 3 5/8"	*70LB* *50LB* *55LB*	1
	2303930	MOTOR REST-RIGHT, 3 1/4"	*42LB* *45LB*	1
384	2303937	MOTOR REST-LEFT, 3 5/8"	*70LB* *50LB* *55LB*	1
	2303935	MOTOR REST-LEFT, 3 1/4"	*42LB* *45LB*	1
386	2303430	SCREW-1/4-20 X 5/8-SELFTAP ZP		5
388	2305110	PAD-PIVOT SUPT ZINC		4
390	2305103	PIVOT PAD, DUROMETER 90A		2
392	2300500	PIN-LATCH		1
394	2300510	PIN-PIVOT		1
396	2013100	NUT-SPEED		4
398	2303612	ROD-RELEASE (RT/AP) S/S		1
400	2322700	SPRING-TORSION		1
402	2303710	LEVER-RELEASE		1
404	2300101	RELEASE-KNOB		1
406	2301700	SPACER-RELEASE LEVER-BRASS		1
408	2304084	CONTROL BRD-12V V2 W/O AP	*42LB 54"* *45LB 48"* *50LB 54"* *55LB 54"* *55LB 48" PONTOON*	1
	2304085	CONTROL BRD-24V V2 W/O AP	*70LB 60"* *70LB 60" DSC* *70LB 48" PONTOON*	1
	2304087	CONTROL BOARD-24V V2 W/AP	*70LB 54" GPS* *70LB 60" DSC GPS*	1
	2304086	CONTROL BOARD-12V V2 W/AP	*45LB 54" GPS* *55LB 54" GPS* *55LB 54" DCS GPS*	1
410	2303434	SCREW-#8-32 X 5/8 MACH PHCR SS		3
412	2090651	LEADWIRE, 10 GA		1
414	2321310	STRAIN RELIEF		1
416	2323405	SCREW-1/4-20 X 1/2" MCH SS		1
418	2306570	HOUSING-CENTER, POWERDRIVE		1
420	2074071	BATTERY METER, 24V	*70LB*	1
	2074070	BATTERY METER, 12V	*42LB* *45LB* *50LB* *55LB*	1
422	2383428	SCREW-#4-24 X 5/8 HI-LO SS		1
424	2320710	TERMINAL-AMP (T-TAB)	*55LB 54" DSC* *55LB 54" DSC GPS* *70LB 54" DSC* *70LB 60" DSC* *70LB 60"* *70LB 60" DSC GPS* *70LB 48" PONTOON*	1

▲ Not shown on Parts Diagram.

* This part is included in an assembly and cannot be ordered individually.

PARTS DIAGRAM & PARTS LIST



Item	Part #	Description	Notes	Quantity
426	2325401	SHRINK TUBE-3/4 ID X 2" W/ADHS	*55LB 54" DSC* *55LB 54" DSC GPS* *70LB 54" GPS* *70LB 60"* *70LB 60" DSC* *70LB 60" DSC GPS* *70LB 48" PONTOON*	1
428	2315612	DECAL-BAT METER, PD, FW, BLK		1
430	2302935	STRAIN RELIEF-DR. HOUSING		1
432	2303980	SIDEPLATE-RIGHT PD MK		1
434	2303985	SIDEPLATE-LEFT PD MK		1
436	2991284	COIL CORD W/STRAIN RLF,PD 60"	*70LB 60"* *70LB 60" DSC* *70LB 60" DSC GPS*	1
	2991280	COIL CRD W/STRN RLF, PD 48"/54"	*42LB 54"* *45LB 48"* *45LB 54"* *45LB 54" GPS* *50LB 54"* *55LB 54"* *55LB 54" GPS*	1
	2991283	COIL CORD W/STRN RLF, PD 48"/54"	*55LB 54" DSC* *55LB 54" DSC GPS* *70LB 54" GPS*	1
438	2307313	BEAD-FERRITE		1
440	2305401	SHRINK TUBE-.374 ID X 1.5"		4
442	2305410	SHRINK TUBE-.315 OD X 2.25"		3
444	2305415	SHRINK TUBE-.472 ID X 2.25"		1
446	2263462	SCREW-1/4-20 X 2" S/S PPH ADJT		6
448	2261713	WASHER-1/4 FLAT 18-8 SS		6
450	2263103	NUT-1/4-20 NYLOCK SS		6
452	2301720	WASHER-MOUNTING - RUBBER		6
454	2375400	SHRINK TUBE-1/4OD X 1-3/4		1
456	2320715	ADAPTER-TAB .25 F-F	*55LB 54" DSC* *55LB 54" DSC GPS* *70LB 54" GPS* *70LB 60" DSC* *70LB 60"* *70LB 60" DSC GPS*	1
458	2266730	LEADWIRE W/PLUG,12/24V,PD,TRKR	*TRACKER*	1
	2996717	TRACKET PLUG/LEADWIRE ASSY	*TRACKER* *70LB 60"*	1
460	2323404	SCREW -1/4-20X1/2" T-L ZP		4
▲	2015800	HANG TAG "CAUTION...TILT HINGE"		1
464	2030710	CONNECTOR BUTT	*42LB 54"*	2
466	2030317	WIRE EXTENSION-18"-RED	*42LB 54"*	1
468	2030316	WIRE EXTENSION-18"-BLACK	*42LB 54"*	1

▲ Not shown on Parts Diagram.

✘ This part is included in an assembly and cannot be ordered individually.



RECOMMENDED ACCESSORIES

› ON-BOARD & PORTABLE BATTERY CHARGERS

Stop buying new batteries and start taking care of the ones you've got. Many chargers can actually damage your battery over time – creating shorter run times and shorter overall life. Digitally controlled Minn Kota chargers are designed to provide the fastest charge that protect and extend battery life.



MK212PCL



MK210D



MK110PD

› TALON SHALLOW WATER ANCHOR

Talon is the only shallow water anchor with up to 15' of anchoring depth, multiple anchoring modes, and control from the bow, transom, console, remote or mobile device.



BUILT-IN WORK LIGHT

Lets you tie lines and work from the transom any time of day — or night. Includes both white and blue LED lights with three brightness settings.



UP TO 15' DEEP

Control more water and catch more fish with the first 15' shallow water anchor.



BLUETOOTH® CONNECTIVITY

Lets you control Talon from your mobile device and easily update it. Also opens up communication to other control options.



MORE CONTROL OPTIONS

- Control Panel
- Wireless Remote
- Mobile App
- Wireless Foot Switch
- Humminbird® Connectivity
- Advanced GPS Navigation System Remote



› MINN KOTA ACCESSORIES

We offer a wide variety of trolling motor accessories, including:

- 60-Amp Circuit Breaker
- Mounting Brackets
- Stabilizer Kits
- Extension Handles
- Battery Connectors
- Battery Boxes
- Quick Connect Plugs



minnkota.johnsonoutdoors.com



Part #2317124

Minn Kota Consumer & Technical Service
Johnson Outdoors Marine Electronics, Inc.
PO Box 8129
Mankato, MN 56001

121 Power Drive
Mankato, MN 56001
Phone (800) 227-6433
Fax (800) 527-4464



©2024 Johnson Outdoors Marine Electronics, Inc.
All rights reserved.

ECN 44756

Rev D

03/24