

ULTREX® QUEST™

BOW-MOUNT TROLLING MOTOR
Installation Instructions

INTRODUCTION

THANK YOU

Thank you for choosing Minn Kota. We believe that you should spend more time fishing and less time positioning your boat. That's why we build the smartest, toughest, most intuitive trolling motors on the water. Every aspect of a Minn Kota trolling motor is thought out and rethought until it's good enough to bear our name. Countless hours of research and testing provide you the Minn Kota advantage that can truly take you "Anywhere. Anytime." We don't believe in shortcuts. We are Minn Kota. And we are never done helping you catch more fish.

REGISTRATION

Remember to keep your receipt and immediately register your trolling motor on our website at minnkota.johnsonoutdoors.com/register.

SERIAL NUMBER

Your Minn Kota 11-character serial number is very important. It helps to determine the specific model and year of manufacture. When contacting consumer service or registering your product, you will need to know your product's serial number.

NOTICE: The serial number on the Ultrex QUEST is located under the base of the foot pedal.

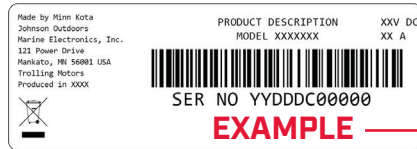
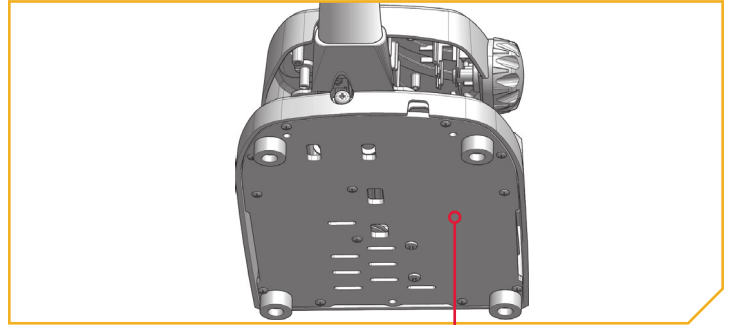

MOTOR INFORMATION (For Consumer Reference Only)

Model: _____

Serial Number: _____

Purchase Date: _____

Store Where Purchased: _____

NOTICE: Do not return your Minn Kota motor to your retailer. Your retailer is not authorized to repair or replace this unit. You may obtain service by: calling Minn Kota at (800) 227-6433; returning your motor to the Minn Kota Factory Service Center; sending or taking your motor to any Minn Kota authorized service center. A list of authorized service centers is available on our website, at minnkota.johnsonoutdoors.com. Please include proof of purchase, serial number and purchase date for warranty service with any of the above options.

Made for iPhone® 11 and iPhone X

For updated iOS, Humminbird® and Minn Kota® compatibility, visit minnkota.johnsonoutdoors.com



Use of the Made for Apple badge means that an accessory has been designed to connect specifically to the Apple product(s) identified in the badge, and has been certified by the developer to meet Apple performance standards. Apple is not responsible for the operation of this device or its compliance with safety and regulatory standards. iPhone is a trademark of Apple Inc., registered in the U.S. and other countries. The trademark "iPhone" is used in Japan with a license from Aiphone K.K.

Android™ is a trademark of Google LLC. The Android robot is reproduced or modified from work created and shared by Google and used according to terms described in the Creative Commons 3.0 Attribution License.

SAFETY CONSIDERATIONS

Please thoroughly read the user manual. Follow all instructions and heed all safety and cautionary notices. Use of this motor is only permitted for persons that have read and understood these user instructions. Minors may use this motor only under adult supervision.

WARNING

You are responsible for the safe and prudent operation of your vessel. We have designed your Minn Kota product to be an accurate and reliable tool that will enhance boat operation and improve your ability to catch fish. This product does not relieve you from the responsibility for safe operation of your boat. You must avoid hazards to navigation and always maintain a permanent watch so you can respond to situations as they develop. You must always be prepared to regain manual control of your boat. Learn to operate your Minn Kota product in an area free from hazards and obstacles.

WARNING

Never run the motor out of the water, as this may result in injuries from the rotating propeller. The motor should be disconnected from the power source when it is not in use or is off the water. When connecting the power-supply cables of the motor to the battery, ensure that they are not kinked or subject to chafe and route them in such a way that persons cannot trip over them. Before using the motor make sure that the insulation of the power cables is not damaged. Disregarding these safety precautions may result in electric shorts of battery(s) and/or motor. Always disconnect motor from battery(s) before cleaning or checking the propeller. Avoid submerging the complete motor as water may enter the lower unit through control head and shaft. If the motor is used while water is present in the lower unit considerable damage to the motor can occur. This damage will not be covered by warranty.

WARNING

Take care that neither you nor other persons approach the turning propeller too closely, neither with body parts nor with objects. The motor is powerful and may endanger or injure you or others. While the motor is running watch out for persons swimming and for floating objects. Persons whose ability to run the motor or whose reactions are impaired by alcohol, drugs, medication, or other substances are not permitted to use this motor. This motor is not suitable for use in strong currents. The constant noise pressure level of the motor during use is less than 70dB(A). The overall vibration level does not exceed 2,5 m/sec².

WARNING

When stowing or deploying the motor, keep fingers clear of all hinge and pivot points and all moving parts. In the event of unexpected operation, remove power leads from the battery.

WARNING

It is recommended to only use Johnson Outdoors approved accessories with your Minn Kota motor. Using non-approved accessories including to mount or control your motor may cause damage, unexpected motor operation and injury. Be sure to use the product and approved accessories, including remotes, safely and in the manner directed to avoid accidental or unexpected motor operation. Keep all factory installed parts in place including motor and accessory covers, enclosures and guards.

SAFETY CONSIDERATIONS



WARNING

- **INGESTION HAZARD:** This product contains a button cell or coin battery.
- **DEATH** or serious injury can occur if ingested.
- A swallowed button cell or coin battery can cause **Internal Chemical Burns** in as little as **2 hours**.
- **KEEP** new and used batteries **OUT OF REACH** of **CHILDREN**
- **Seek immediate medical attention** if a battery is suspected to be swallowed or inserted inside any part of the body.



1. This product contains a button/coin cell battery. Heed all safety considerations:
 - a) Remove and immediately recycle or dispose of used batteries according to local regulations and keep away from children. Do NOT dispose of batteries in household trash or incinerate.
 - b) Even used batteries may cause severe injury or death.
 - c) Call a local poison control center for treatment information.
 - d) The compatible battery type is CR2450.
 - e) The nominal battery voltage is 3.0 VDC.
 - f) Non-rechargeable batteries are not to be recharged.
 - g) Do not force discharge, recharge, disassemble, heat above (manufacturer's specified temperature rating) or incinerate. Doing so may result in injury due to venting, leakage or explosion resulting in chemical burns.
2. This product contains a replaceable button/coin cell battery. Heed all safety considerations:
 - a) Ensure the batteries are installed correctly according to polarity (+ and -).
 - b) Do not mix old and new batteries, different brands or types of batteries, such as alkaline, carbon-zinc, or rechargeable batteries.
 - c) Remove and immediately recycle or dispose of batteries from equipment not used for an extended period of time according to local regulations.
 - d) Always completely secure the battery compartment. If the battery compartment does not close securely, stop using the product, remove the batteries, and keep them away from children.

KNOW YOUR BOAT

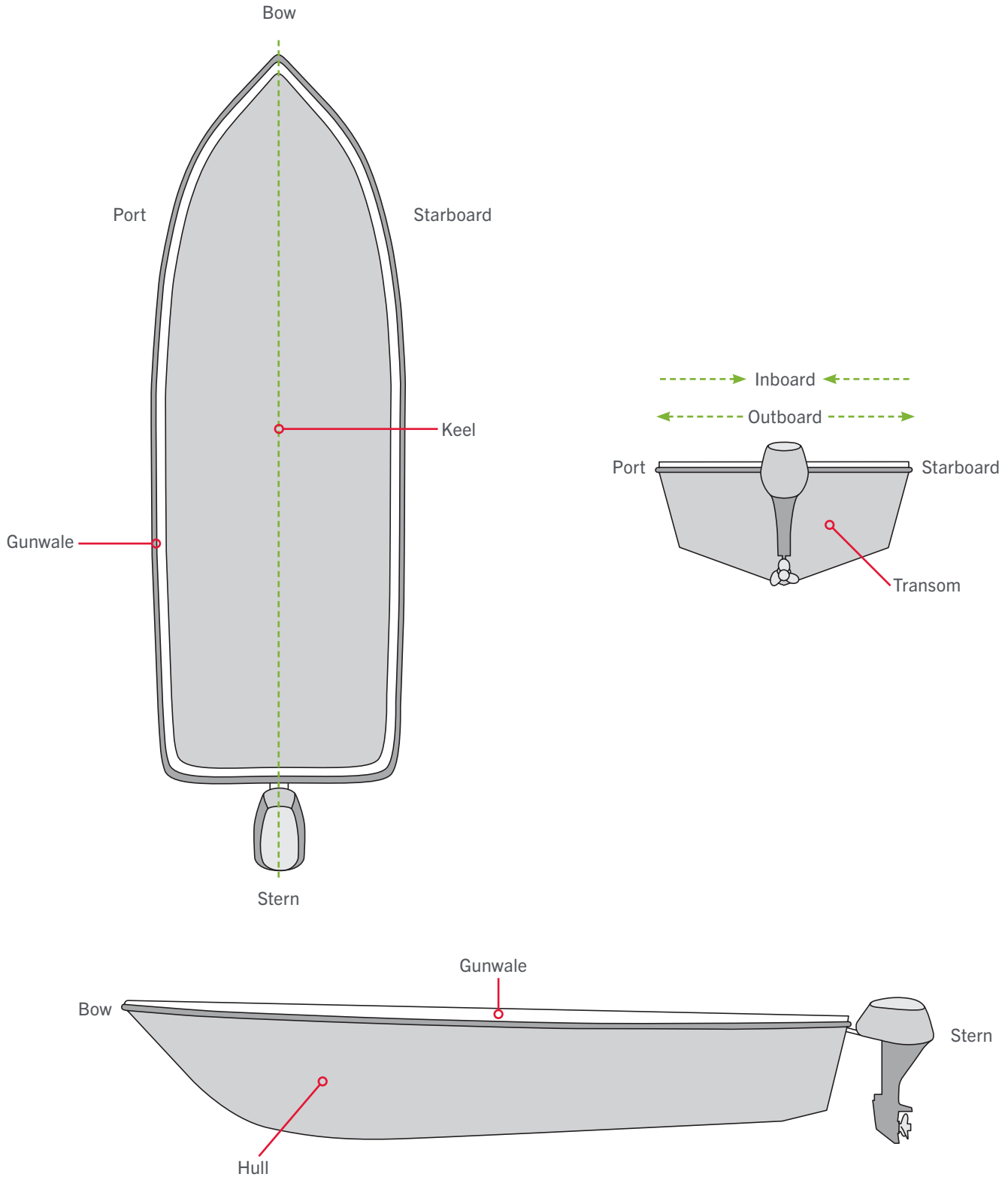

INSTALLATION

INSTALLING THE ULTREX QUEST

Your new Ultrex QUEST comes with everything you'll need to install it to the boat. This motor can be directly mounted to the boat or coupled with a Minn Kota quick release bracket for ease of mounting and removal. For installation with a quick release bracket, refer to the installation instructions provided with the bracket. For compatible quick release mounting brackets and to locate your nearest dealer, visit minnkota.johnsonoutdoors.com. To install the motor directly to the boat, please follow the instructions provided in this manual. Please review the parts list, mounting considerations and tools needed for installation prior to getting started. For additional product support, please visit minnkota.johnsonoutdoors.com.

INSTALLATION PARTS LIST

Item/Assembly	Part #	Description	Qty.
A	*	MOTOR ASSEMBLY	1
B	2994947	BAG ASM, ULTREX 2 HARDWARE	1
Includes 2-8			
2	2293406	SCREW-5/16-18X 2.25" PPH SS	6
4	2223100	NUT-5/16-18 NULOCK S/S	6
6	2291701	WASHER-5/16X 1.5 FLAT SS	6
8	2378608	ANTI SEIZE TUBE, 4CC	1
10	2394110	TAG, MICRO REMOTE	1
C	2994175	REMOTE ASM, MICRO REMOTE	1
12	2390802	LANYARD W/CARABINR, IP RMT	1
14	2263806	STRAP-HLD DWN, 33", HOOK&LP	1
16	490384-4	CABLE, ETHERNET (M12-M12) 30'	1
18	490380-1	CABLE, ETHERNET PIGTAIL-700 HD	1
20	2373434	SCREW-1/4-20 X 3/4 SS PPMS	4
D	2991665	MOUNT ASM, UTX, FW, SHORT	1
E	2991666	MOUNT ASM, UTX, FW, LONG	1
F	2991925	BRACKET STABLZR ARM ASY	1
Includes 22-36			
22	2265100	BUMPER STABILIZER	1
24	2263624	STABILIZER ROD	1
26	2263107	NYLON HEX NUT 3/4 - 10 UNC	1
28	2281929	BRACKET	1
30	2260221	VINYL CAP	1
32	2223100	NUT 5/16-18 NYLOCS SS	2
34	2263422	BOLT 5/16-18 X 1" SS CAP SCREW	2
36	2281700	5/16" ID X .457 OD HIGH COLLAR LOCK WASHER	2
38	2321162	PROP WW2 BRUSHLESS MACHINED	1
	2321170	PROP, POWER REAMED	1
CC	2992604	BAG ASSM, PROP HARDWARE	1
Includes 40-44			
40	2091701	WASHER-PROP (LARGE)	1
42	2093101	NUT-PROP NYLOC, LG, MX101 3/8 SS	1
44	2262658	PIN-DRIVE 1" 3/16" S/S	1
46	2994960	BAG ASM, CABLE ADPT, 490518-1 *490518-1* *MKR-MDI-2*	1
48	2994961	BAG ASM, CABLE ADPT, 490537-2 *490537-2* *MKR-MI-1*	1
G	540321-1	HDWE, BGD, 1.5" SHAFT MNT-ML *HUMMINBIRD 360 BRACKET ADAPTER*	1
▲	2997167	INSTALL GUIDE, ULTREX 2	1
▲	2297166	MANUAL, ULTREX 2	1
▲	2297165	MANUAL-DISCLAIMER, DWNLOAD INFO	1
▲	2394912	QCK REF.GUIDE, IP MICRO RMT BT	1
▲	2394910	INSTRUC. SHEET, MICRO REMO	1
▲	2294950	INSTRUCT, OBN & REMOTE PAIR	1
▲	2207130	BRUSHLESS QS SETUP GUIDE	1

▲ Not shown on Parts Diagram.

* This part is included in an assembly and cannot be ordered individually.

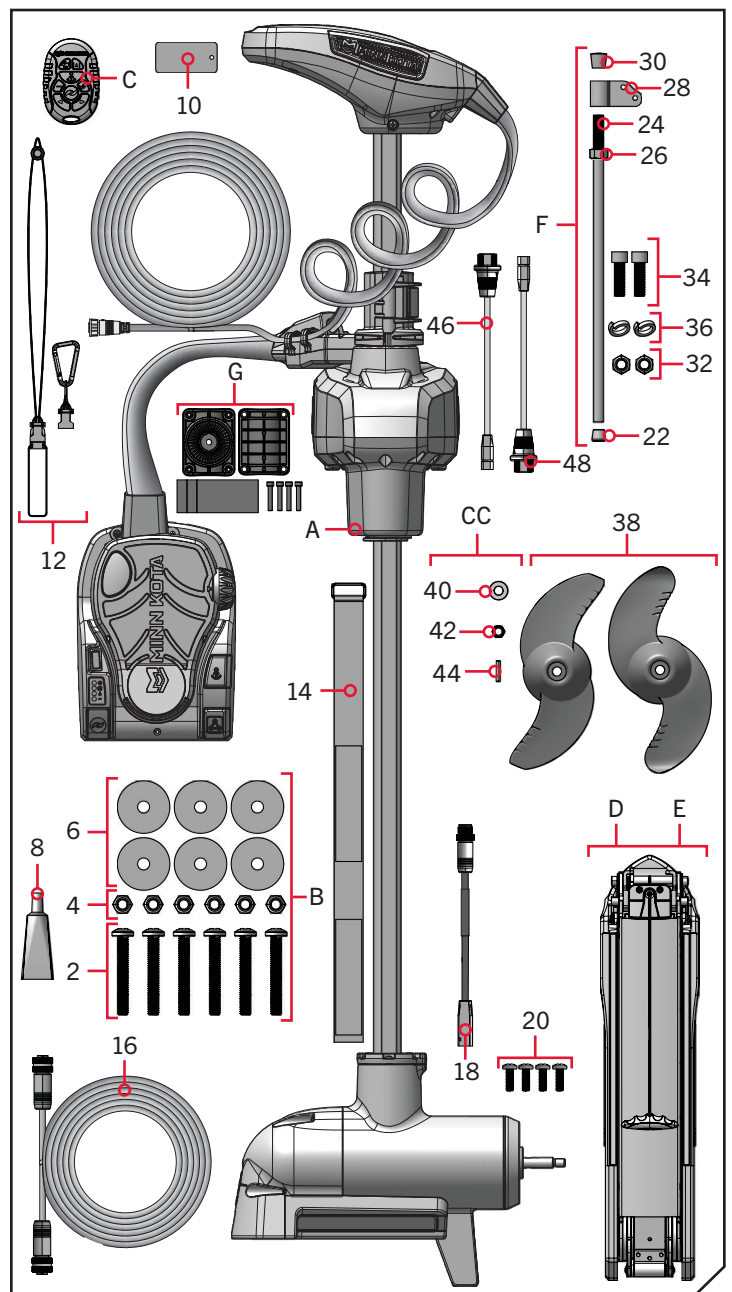

ASSEMBLY OF STEERING MODULE TO MOUNT

MOUNTING CONSIDERATIONS

It is recommended that the motor be mounted as close to the keel or centerline of the boat as possible. Make sure the area under the mounting location is clear to drill holes and install nuts and washers. Make sure the motor rest is positioned far enough beyond the edge of the boat. The motor must not encounter any obstructions as it is lowered into the water or raised into the boat when stowed and deployed. Consider a quick release or adapter bracket with the installation of your motor. To view a list of accessories, please visit minnkota.johnsonoutdoors.com.



View accessories available for your trolling motor at minnkota.johnsonoutdoors.com.

TOOLS AND RESOURCES REQUIRED

- #2 Phillips Screwdriver
- #3 Phillips Screwdriver
- #4 Phillips Screwdriver
- 1/4" Allen Wrench
- Drill
- 21/64" Drill Bit
- 1/2" Box End Wrench
- Torque Wrench
- A person to help with installation
- File or Sandpaper
- Hack Saw
- Marker or Pencil
- 1/8" Flat-Blade Screwdriver
- Ruler or Measuring Tool
- 9/16" Open End Wrench
- 9/16" Deep Well Socket
- 5/64" Allen Wrench

INSTALLATION

Assembly of Steering Module to Mount

1

ITEM(S) NEEDED

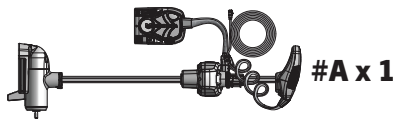

- a. The Power Cables for the Ultrex QUEST trolling motor exit the Foot Pedal. The Foot Pedal is a part of the Motor Assembly (Assembly #A) and is attached to the Steering Module by way of the Pedal Control Sleeve Assembly. Before beginning installation of the trolling motor, confirm that the trolling motor Power Cables are not connected to a power source.

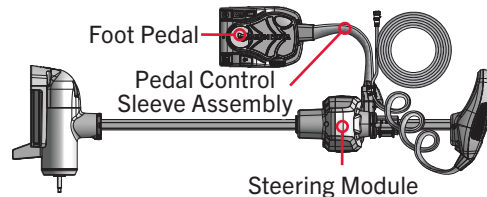

WARNING

Avoid the risk of electric shock or unexpected motor operation. Always make sure the Power Cables are not connected to a power source before beginning installation.

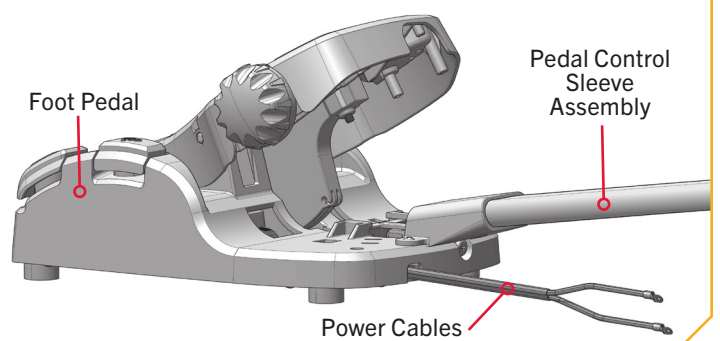

ASSEMBLY OF STEERING MODULE TO MOUNT

2

ITEM(S) NEEDED



#D x 1 or #E x 1

- b. Place the Mount (Assembly #D or #E) on an elevated, level surface such as a workbench or the tailgate of a pickup. The Mount, as removed from the box, should be in the deployed position.
- c. Locate the two 5/16" Allen Screws and Lock Washers. They are on the top of the Mount. One set is positioned on each side of the location where the Pull Grip and Cable exit the Mount. Remove the two 5/16" Allen Screws and Lock Washers from the Mount using a 1/4" Allen Wrench.

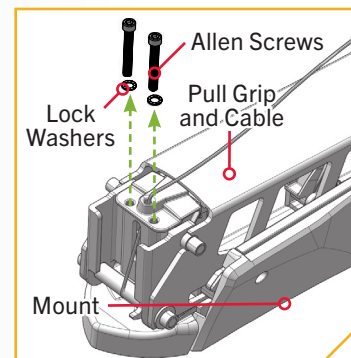
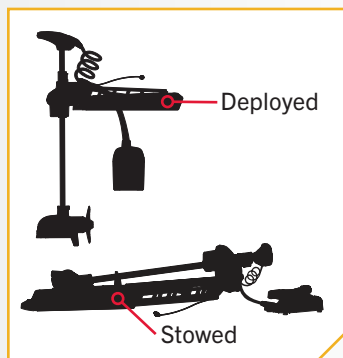

3

- d. Before installing the Mount to the boat, install the Steering Module to the Mount. Ensure the Mount is positioned flat.



WARNING

Place the trolling motor on a level surface to prevent it from falling.

- e. Take the Steering Module and align the Keyways on the inside of the Steering Module with the Pivot Pins on the Mount. Do this by positioning the Steering Module above the Pivot Pins on the Mount. The aluminum extrusion on the inside of the Steering Module is keyed with the end of the Mount. In order for the Steering Module to fully seat, all points of contact between the Steering Module and Mount must align.
- f. Lower the Motor Assembly straight down until the Steering Module is seated.

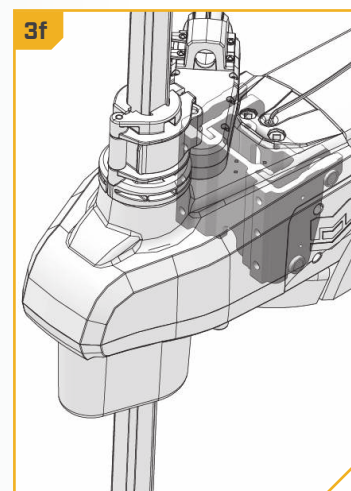
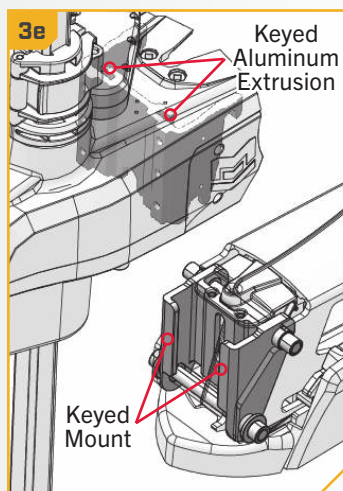
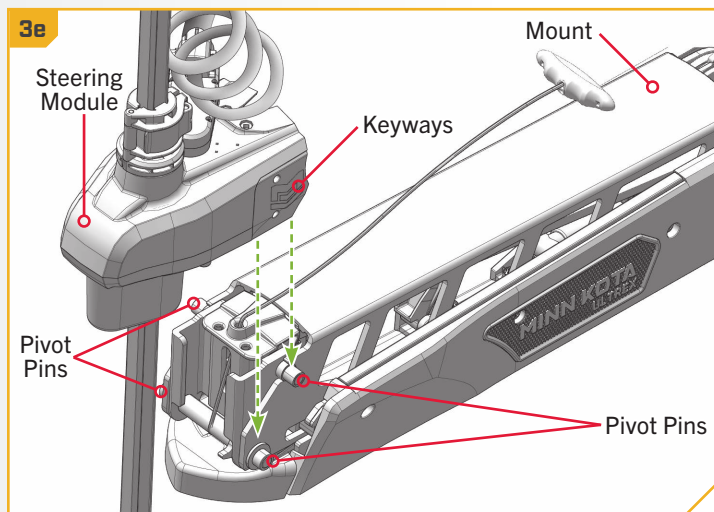

ASSEMBLY OF STEERING MODULE TO MOUNT

4

- g. Ensure the Steering Module is fully seated before securing.



WARNING

Carefully lower the Steering Module into place to avoid creating a pinch point between the Steering Module and Mount.

- h. Reinstall the two 5/16" Allen Screws and Lock Washers with a 1/4" Allen Wrench and tighten to 18 to 20 ft-lbs with a Torque Wrench.

NOTICE: The 5/16" Allen Screws must be tightened when installed and periodically tightened to 18 to 20 ft-lbs. Tighten the Allen Screws when the Mount is in the deployed position.

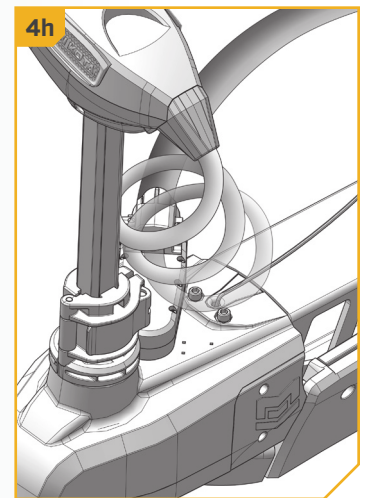
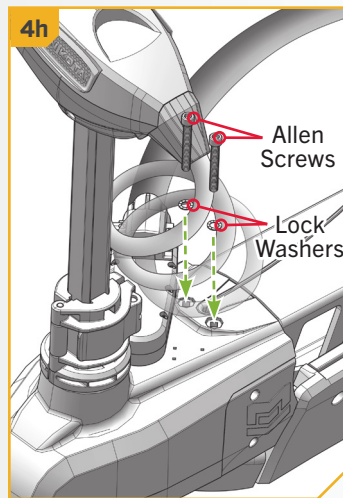
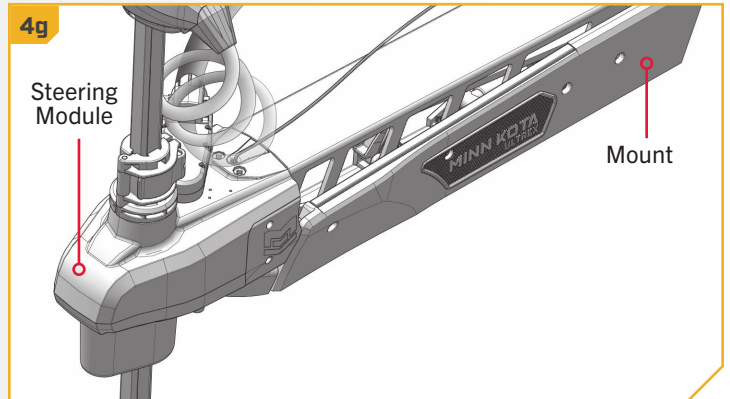

INSTALLING THE BOW-MOUNT

› Installing the Bow-Mount

With the Steering Module installed on the Mount, the Mount can be secured to the bow of the boat. The Mount is not yet fully functional until the two Gas Springs inside the Mount are installed. It is recommended to install the motor to the boat deck before securing the Gas Springs. The Gas Springs work to enable Lift-Assist and are located inside the Outer Arm, a part of the Mount. At this point in the installation, the Gas Springs are not fully assembled and may move around inside the Mount when stowing and deploying the motor. The Gas Springs can become damaged while deploying the motor, and the damage will prevent the Lift-Assist feature from operating correctly once fully assembled. Handle the motor carefully to ensure that the Gas Springs are not damaged in the Mount during installation.

CAUTION

The two Gas Springs can become damaged in the Mount while stowing or deploying the motor because they are not yet fully installed. Damage to the Gas Springs will prevent the Lift-Assist feature from operating correctly once fully assembled. Ensure that the Gas Springs are not damaged by keeping them inside the Outer Arm of the Mount.

1

ITEM(S) NEEDED



- a. Review the mounting considerations at the beginning of the Installation section for proper placement. The motor is intended to be mounted on the bow of the boat deck. Place the Mount as close to the centerline or keel of the boat as possible. The motor should be in the stowed position. Check the placement on the boat deck with the motor in the stowed and deployed positions.
- b. Place the Hold-Down Strap (Item #14) under the base of the Mount Plate so that it is below the Mount when placed.

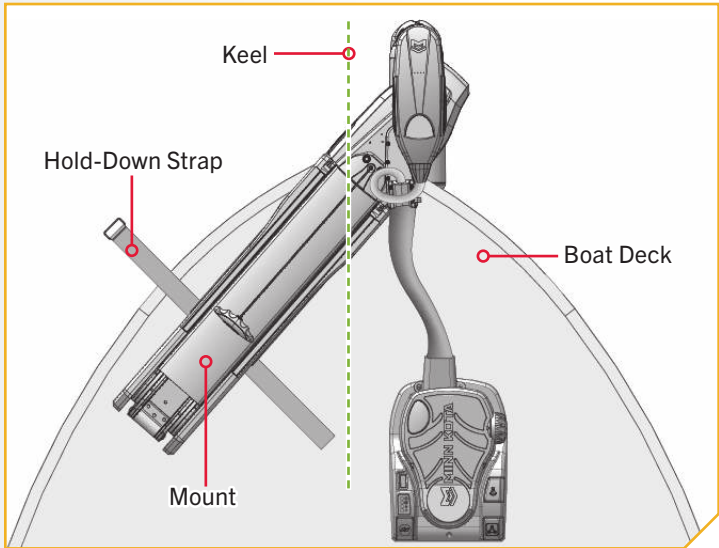

NOTICE: This motor weighs approximately 78 lbs. Minn Kota recommend having a second person help with the installation.

NOTICE: Check that the Motor can properly stow and deploy at the intended mounting location. The Mount should latch closed when deployed. A proper deployment requires engaging the Pull Grip and Cable when the Motor is stowed to unlatch the Mount. If the latch on the Mount does not engage when deployed, it could indicate that the Mount is not flat on the Boat Deck. Use rubber washers to level the Mount on the Boat Deck if the Mount is not latching when deployed.

INSTALLING THE BOW-MOUNT

2

- c. Install the Mount on either the Port or Starboard side of the bow, based on personal preference. Test the placement of the Hold-Down Strap to be sure it can hold the Mount as placed. The position of the buckle on the Hold-Down Strap, either inboard or outboard, is based on personal preference. The hook and loop on the Hold-Down Strap should face downward for the Hold-Down Strap to function correctly.

NOTICE: If personal preference is to mount the motor on the starboard side of the boat, please see the "Rotate the Pedal Control Sleeve Assembly for a Starboard Mount" after the Mount is secured to the deck of the boat.

Port

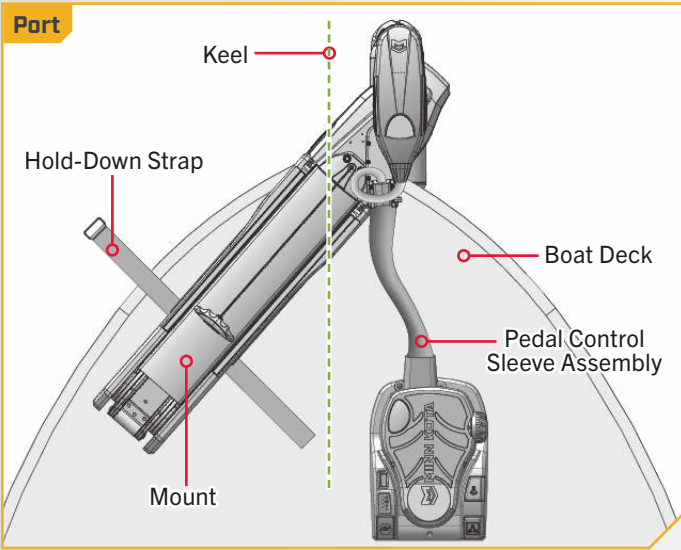

Starboard

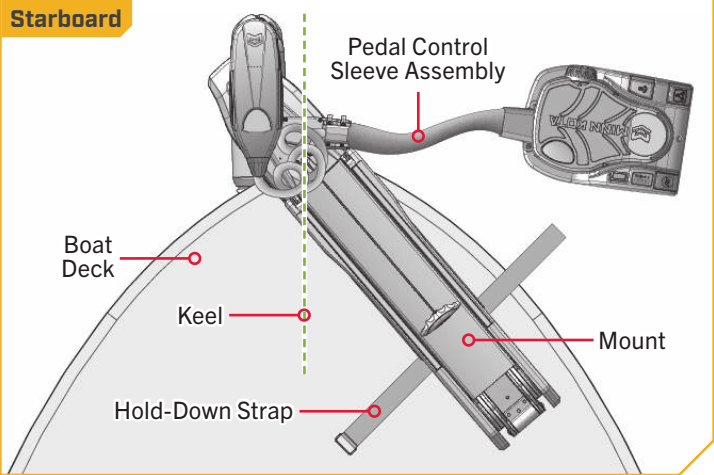

3

- d. Check the placement of the motor in the deployed position. With the motor deployed, ensure that the Steering Module and Shaft are a minimum of 1-1/2" out past the Gunwale of the boat. When stowed and deployed, the Lower Unit must not encounter any obstructions.
- e. Check the placement of the Hold-Down Strap when the motor is in the stowed and deployed positions and adjust if necessary.

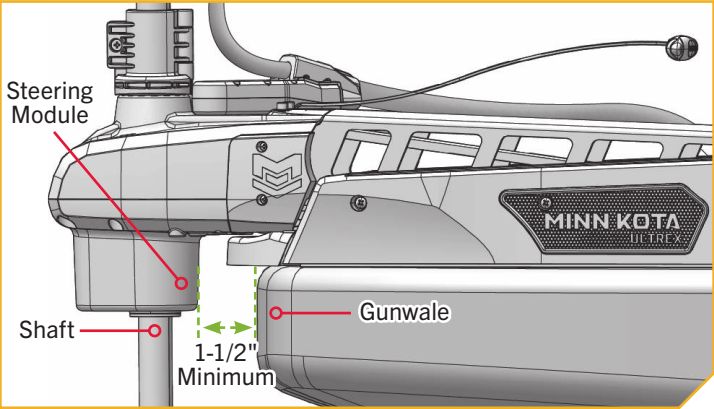

INSTALLING THE BOW-MOUNT

4

- f. Once the Mount is in position, locate the Mounting Holes on the base of the Mount. The motor will have either a Short Mount or a Long Mount. Minn Kota requires the use of all six Mounting Holes.
- g. Mark the Boat Deck for the Mounting Holes with a pencil or marker. Drill through the deck of the boat using a Drill and a 21/64" Drill Bit on the marked locations.
- h. Be sure the Hold-Down Strap under the base of the Mount sits between the second and third set of Mounting Holes from the furthest outboard Mounting Hole. Double check that it can close around the Mount when stowed.
- i. Move the motor to the stowed position to install the hardware once the placement of the Hold-Down Strap is set.

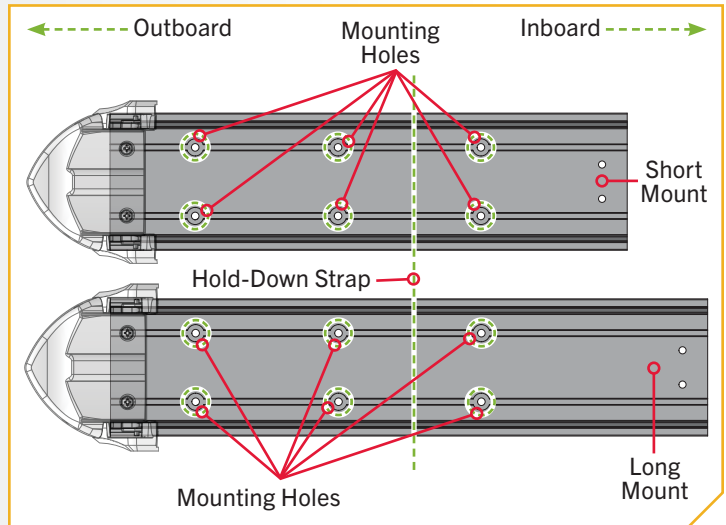

NOTICE: Larger mounting holes are required for customers upgrading from an Ultrex to an Ultrex QUEST. Larger mounting holes will accommodate the higher thrust motor and ensure the installation is secure.

5

ITEM(S) NEEDED



- j. Use the six 5/16" - 18 X 2.25" Stainless Steel Screws (Item #2) and apply Anti-seize (Item #8). Install one Screw in each drilled location. The Screws should pass through the Mounting Holes on the Mount and then the Drilled Holes in the boat deck.
- k. Use the six 5/16" x 1.5" Flat Washers (Item #6) and place one at the end of each Screw. Collect six 5/16" - 18 Nylock Nuts (Item #4) and secure each Screw and Washer with one Nylock Nut. While holding each Nylock Nut with a 1/2" Box End Wrench, use a #4 Phillips Screwdriver to tighten each Screw. Make sure all hardware is secure.

NOTICE: To prevent seizing of the stainless steel hardware, do not use high speed installation tools. Wetting the screws or applying an anti-seize may help prevent seizing.

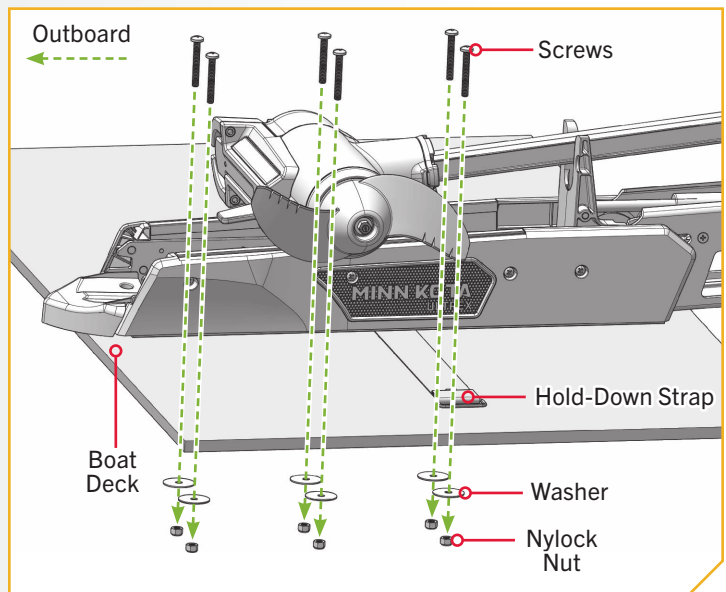

› Installing the Gas Springs

The Ultrex QUEST contains two Gas Springs inside the Mount. The Gas Springs work to enable Lift-Assist in both the stowed and deployed directions and are located inside the Outer Arm, a part of the Mount. At this point in the installation, the Gas Springs are not fully assembled and may move around inside the Mount when stowing and deploying the motor. The Gas Springs can become damaged while moving the Mount, preventing the Lift-Assist feature from operating correctly once fully assembled. Handle the motor carefully to ensure that the Gas Springs are not damaged in the Mount during installation. With the Steering Module installed on the Mount and the Mount secured to the boat deck, install the two Gas Springs.

1

- a. Complete the Mount installation and Steering Module assembly prior to installing the Gas Springs. Then use the Pull Grip and Cable to disengage the Latch Bar on the Mount.
- b. With the help of a second person, unlatch the Depth Collar and position the motor halfway between the stowed and deployed positions. Position the Outer Arm nearly perpendicular to the Base of the Mount.



WARNING

Moving parts can cut or crush. The gas assist lift mechanism is under pressure. Disconnect gas springs before removing motor from mount. Do not engage the Pull Grip and Cable until gas springs are disconnected.



WARNING

The gas assist lift mechanism in this unit is under high spring pressure when the motor is in the deployed position. Do not remove the Steering Module assembly from the mount without disconnecting one end of both gas spring. Failure to do this can create a condition where accidental pulling of the Pull Grip and Cable may cause the mount to spring open rapidly, striking anyone or anything in the direct path.

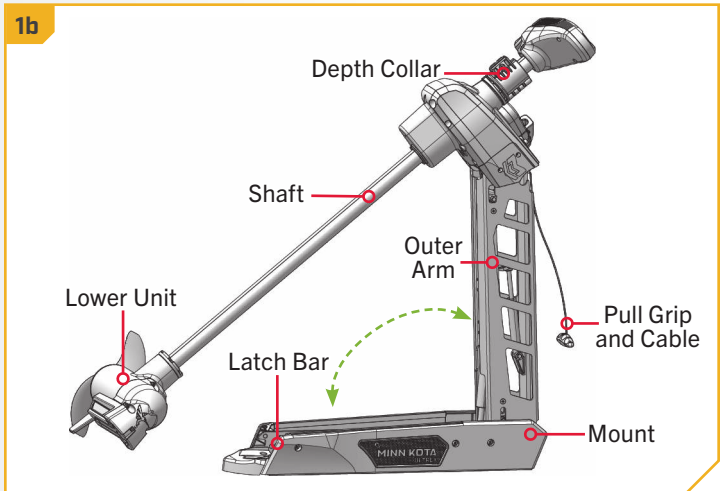
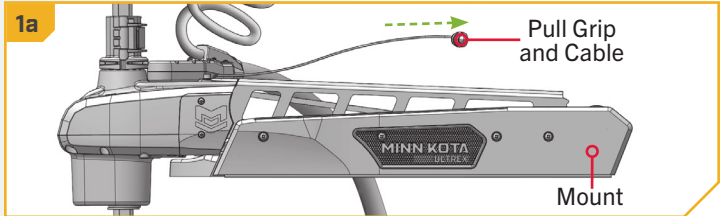

NOTICE: Adjust the Depth Collar on the Shaft as necessary to position the motor. Hold the motor in place while the two Gas Springs are installed.

INSTALLING THE GAS SPRINGS

2

ITEM(S) NEEDED



- c. Two Gas Springs are located inside the Outer Arm. Once the motor is correctly positioned, the Gas Springs can be secured. Start with the larger Gas Spring closest to the Boat Deck, protected with a Paper Tube.
- d. Remove the Paper Tube on the larger Gas Spring and discard it.
- e. There is a loose Bracket on the end of the Gas Spring with holes and recessed Nylock Nuts. Align the Bracket with the lower two holes in the Outer Arm. Adjust the motor as needed to align the Bracket.
- f. Take two Pan Head Phillips Machine Screws (Item #20) and install them through the holes in the Outer Arm and into the Bracket at the end of the Gas Spring using a #3 Screwdriver. Tighten to 35 in-lbs.

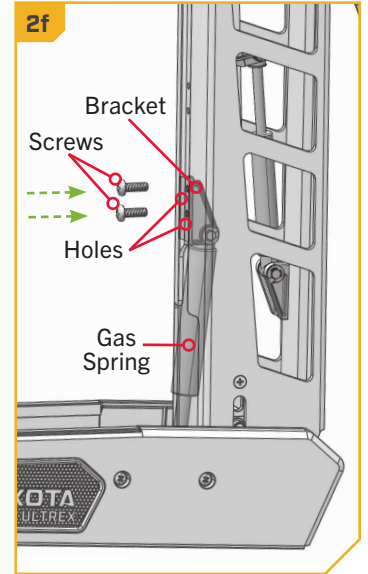
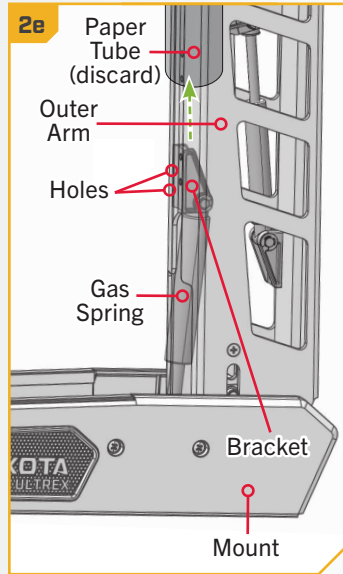

3

ITEM(S) NEEDED



- g. The Bracket attachment for the second, smaller Gas Spring sits above the Gas Spring just installed.
- h. Align the Bracket of the second Gas Spring with the upper two holes in the Outer Arm. Adjust the motor as needed.
- i. Take two Pan Head Phillips Machine Screws (Item #20) and install them through the holes in the Outer Arm and into the Bracket at the end of the Gas Spring using a #3 Screwdriver. Tighten to 35 in-lbs.

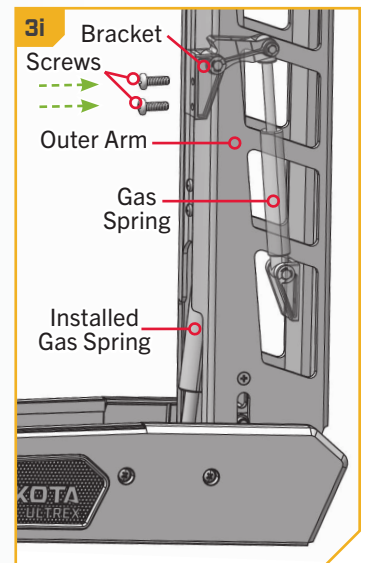
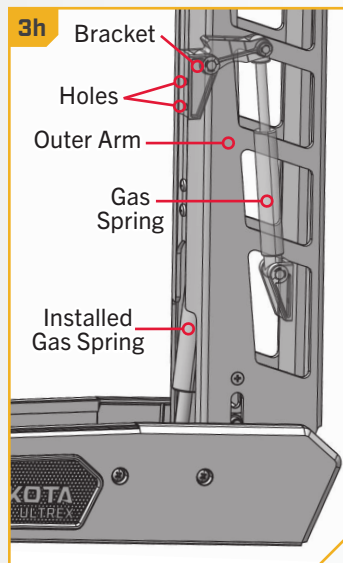

BATTERY & WIRING INSTALLATION

BOAT RIGGING & PRODUCT INSTALLATION

For safety and compliance reasons, we recommend that you follow American Boat and Yacht Council (ABYC) standards when rigging your boat. Altering boat wiring should be completed by a qualified marine technician. The following specifications are for general guidelines only:

CAUTION

These guidelines apply to general rigging to support your Minn Kota motor. Powering multiple motors or additional electrical devices from the same power circuit may impact the recommended conductor gauge and circuit breaker size. If you are using wire longer than that provided with your unit, follow the conductor gauge and circuit breaker sizing table below. If your wire extension length is more than 25 feet, we recommend that you contact a qualified marine technician.

CAUTION

An over-current protection device (circuit breaker or fuse) must be used. Coast Guard requirements dictate that each ungrounded current-carrying conductor must be protected by a manually reset, trip-free circuit breaker or fuse. The type (voltage and current rating) of the fuse or circuit breaker must be sized accordingly to the trolling motor used. The table below gives recommended guidelines for circuit breaker sizing.

CONDUCTOR GAUGE AND CIRCUIT BREAKER SIZING TABLE

This conductor and circuit breaker sizing table is only valid for the following assumptions:

1. No more than 2 conductors are bundled together inside of a sheath or conduit outside of engine spaces.
2. Each conductor has 105° C temp rated insulation.
3. No more than 3% voltage drop allowed at full motor power based on published product power requirements.

Motor Thrust / Model	Max Amp Draw	Circuit Breaker		Wire Extension Length				
		Amps	Minimum	5 feet	10 feet	15 feet	20 feet	25 feet
QUEST 24V	60	60 Amp	24 VDC	6 AWG	6 AWG	4 AWG	4 AWG	2 AWG
QUEST 36V	60	60 Amp	36 VDC	6 AWG	6 AWG	6 AWG	6 AWG	4 AWG

NOTICE: Wire Extension Length refers to the distance from the batteries to the trolling motor leads. Consult website for available thrust options.

Reference

United States Code of Federal Regulations: 33 CFR 183 – Boats and Associated Equipment ABYC E-11: AC and DC Electrical Systems on Boats

SELECTING THE CORRECT BATTERIES



SELECTING THE CORRECT BATTERIES

QUEST series trolling motors will operate with any deep cycle marine 12, 24 or 36-volt battery/batteries and have been optimized for use with LiFePO₄ Lithium Ion battery cells. Lithium Ion batteries maintain higher voltages for more extended periods than lead-acid batteries and will provide the best performance in powering the trolling motor.

QUEST series trolling motors may also be powered with lead-acid (flooded, AGM, or GEL) deep-cycle marine 12-volt battery/batteries. For best results Minn Kota recommends using a deep-cycle marine battery with rating outlined in the "Deep Cycle Amp-Hour Rating" table. Maintain lead-acid batteries at full charge. Proper care will ensure battery power when needed and significantly improve battery life. Failure to recharge lead-acid

Deep Cycle Amp-Hour Rating			
Run Time	Voltage	Group Size	Amp-Hour
GOOD	12	24	70-85
BETTER	12	27	85-110
BEST	12	31	95-125

batteries (within 12-24 hours) is the leading cause of premature battery failure. Use a multi-stage charger to avoid overcharging. When using Lithium Ion batteries, manufacturers may recommend storing in a semi-charged state and charging fully prior to use.

If using a crank battery to start a gasoline outboard, Minn Kota recommends using a separate battery/batteries for your Minn Kota trolling motor. Always check with the battery manufacturer for specific maintenance, care and storage instructions. Minn Kota also offers a wide selection of chargers to fit your charging needs. For more information on battery selection, rigging, and chargers, please visit minnkota.johnsonoutdoors.com.

WARNING

Never connect the (+) and the (-) terminals of the same battery together. Take care that no metal object can fall onto the battery and short the terminals. This would immediately lead to a short and extreme fire danger.

CAUTION

Refer to "Conductor Gauge and Circuit Breaker Sizing Table" in the previous section to find the appropriate circuit breaker or fuse for your motor. For motors requiring a 60-amp breaker, the Minn Kota MKR-27 60-amp circuit breaker is recommended.

CAUTION

Please read the following information before connecting your motor to your batteries in order to avoid damaging your motor and/or voiding your warranty.

ADDITIONAL CONSIDERATIONS

› Using DC or Alternator Chargers

Your Minn Kota trolling motor may be designed with an internal bonding wire to reduce sonar interference. Most alternator charging systems do not account for this bonding wire, and connect the negative posts of the trolling motor batteries to the negative posts of the crank/starting battery. These external connections can damage connected electronics and the electrical system of your trolling motor, voiding your warranty. Review your charger's manual carefully or consult the manufacturer prior to use to ensure your charger is compatible.

Minn Kota recommends using Minn Kota brand chargers to recharge the batteries connected to your Minn Kota trolling motor, as they have been engineered to work with motors that include a bonding wire. Learn more about Minn Kota chargers online at minnkota.johnsonoutdoors.com.



CONNECTING THE BATTERIES IN SERIES

› Additional Accessories Connected to Trolling Motor Batteries

Significant damage to your Minn Kota motor, your boat electronics, and your boat can occur if incorrect connections are made between your trolling motor batteries and other battery systems. Minn Kota recommends using an exclusive battery system for your trolling motor. Where possible, accessories should be connected to a separate battery system. Radios and sonar units should not be connected to any trolling motor battery systems as interference from the trolling motor is unavoidable. If connecting any additional accessories to any trolling motor battery system, or making connections between the trolling motor batteries and other battery systems on the boat, be sure to carefully observe the information below.

The negative (-) connection must be connected to the negative terminal of the same battery that the trolling motor negative lead connects to. In the diagrams below this battery is labeled “Low Side” Battery. Connecting to any other trolling motor battery will input positive voltage into the “ground” of that accessory, which can cause excess corrosion. Any damage caused by incorrect connections between battery systems will not be covered under warranty.

› Automatic Jump Start Systems and Selector Switches

Automatic jump start systems and selector switches tie the negatives of the connected batteries together. Connecting these systems to the “High Side” Battery or “Middle” Battery in the diagrams below and will cause significant damage to your trolling motor and electronics. The only trolling motor battery that is safe to connect to one of these systems is the “Low Side” Battery.

CONNECTING THE BATTERIES IN SERIES (IF REQUIRED FOR YOUR MOTOR)

› 24 Volt Systems

Two 12 volt batteries are required. The batteries must be wired in series, only as directed in wiring diagram, to provide 24 volts.

1. Make sure that the motor is switched off (speed selector on “0”).
2. Connect a connector cable to the positive (+) terminal of battery 1 and to the negative (-) terminal of battery 2.
3. Connect positive (+) red motor lead to positive (+) terminal on battery 2.
4. Connect negative (-) black motor lead to negative (-) terminal of battery 1.

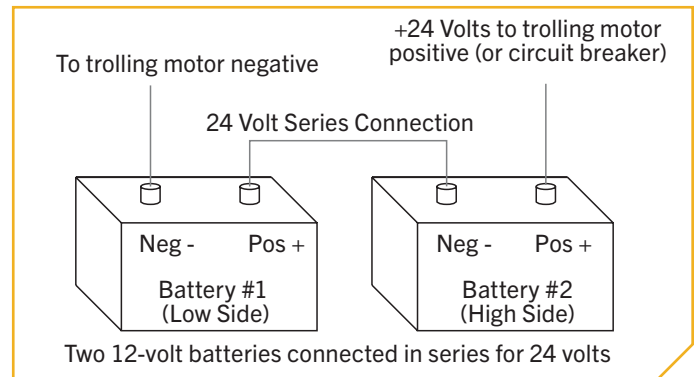

WARNING

For safety reasons do not switch the motor on until the propeller is in the water. If installing a leadwire plug, observe proper polarity and follow instructions in your boat owner’s manual.

WARNING

- For safety reasons, disconnect the motor from the battery or batteries when the motor is not in use or while the battery/batteries are being charged.
- Improper wiring of 24/36 volt systems could cause battery explosion.
- Keep leadwire wing nut connections tight and solid to battery terminals.
- Locate battery in a ventilated compartment.

CONNECTING THE BATTERIES IN SERIES

36-Volt Systems

Three 12-volt batteries are required. The batteries must be wired in series, only as directed in the wiring diagram, to provide 36 volts.

1. Make sure that the motor is switched off (speed selector on "0").
2. Connect a connector cable to the positive (+) terminal of battery 1 and to the negative (-) terminal of battery 2 and another connector cable from the positive (+) terminal of battery 2 to the negative (-) terminal of battery 3.
3. Connect positive (+) red motor lead to positive (+) terminal on battery 3.
4. Connect negative (-) black motor lead to negative (-) terminal of battery 1.

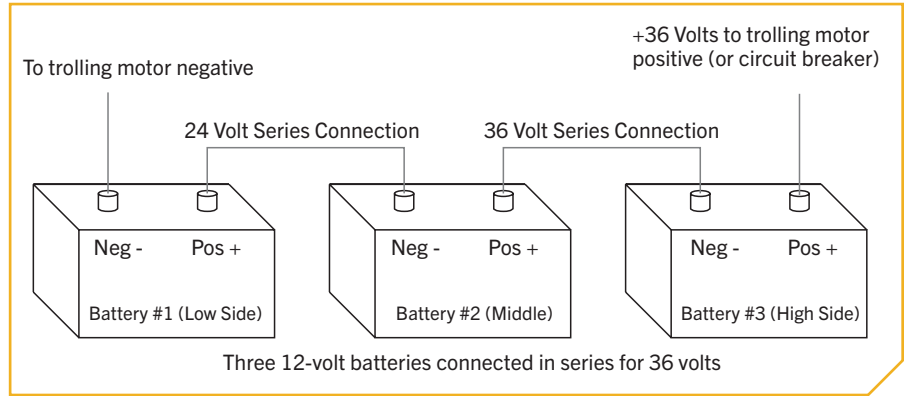

WARNING

For safety reasons, do not switch the motor on until the propeller is in the water. If installing a leadwire plug, observe proper polarity and follow instructions in your boat owner's manual.

WARNING

- For safety reasons, disconnect the motor from the battery or batteries when the motor is not in use or while the battery/batteries are being charged.
- Improper wiring of 24/36 volt systems could cause battery explosion.
- Keep leadwire wing nut connections tight and solid to battery terminals.
- Locate battery in a ventilated compartment.

COMPLETING THE INSTALLATION

COMPLETING THE ULTREX QUEST INSTALLATION

The Ultrex QUEST is an advanced trolling motor. To maximize the performance of the trolling motor, mechanical and electrical systems should be set and calibrated to fit every user's installation. This portion of the installation will cover how to verify power, calibrate or rotate the Pedal Control Sleeve Assembly, install the Bow-mount Stabilizer, and more. The installation will conclude with connecting Accessory Cables and setting motor preferences for ease of use. Minn Kota recommends connecting the trolling motor to the One-Boat Network app to assist in these steps. Find more information in the One-Boat Network App document included with the trolling motor or the One-Boat Network Owner's Manual found online at minnkota.johnsonoutdoors.com.

COMPLETING THE INSTALLATION >

> Verifying Power

Each time the trolling motor is powered "on," the control board will auto-detect the power supplied from the battery system and adjust the thrust output based on a 24V or 36V battery system. To complete the remaining installation steps, connect the Ultrex QUEST to power. At specific points in the installation, power is disconnected or turned "off" to ensure a safe environment for installation. To verify power to the trolling motor, follow the steps below:

1

- a. Turn the Power Switch on the Foot Pedal "on". Locate the Indicator Panel on the Foot Pedal. When powered "on", the Power LED is illuminated blue. When the Power Switch is "off", the Power LED is not illuminated.

NOTICE: The standard power-up sequence for the Ultrex QUEST is for all four LEDs on the Indicator Panel to turn on. The Advanced GPS Navigation System in the Control Head then chirps three times, followed by the blue LED on the Indicator Panel remaining on.

NOTICE: In instances where the trolling motor is updating, all four LEDs will flash while the update is performed. Once the update is complete, the system will self-reboot and perform the normal start-up sequence. If a standard power-up sequence is not experienced, please see the Troubleshooting section of the manual to identify any errors. To learn more about software updates, please see the Owner's Manual for the One-Boat Network or Advanced GPS Navigation Wireless Remote.

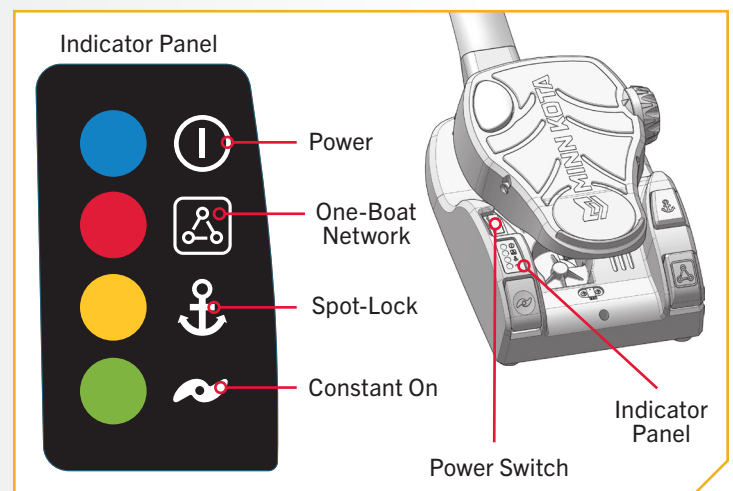

INDEXING THE MOTOR FOR A PORT INSTALLATION

› Indexing the Motor for a Port Installation

The Ultrex QUEST comes from the factory with the Pedal Control Sleeve Assembly set inboard for a Port installation. The recommendation for correct indexing of the trolling motor is to have the Pedal Control Sleeve Assembly, which attaches the Foot Pedal to the Mount, pointing inboard. If the Pedal Control Sleeve Assembly is outboard, please see the section "Rotate the Pedal Control Sleeve Assembly for a Starboard Mount" of this installation. Use the following instructions to index the motor if the Pedal Control Sleeve Assembly is already pointing inboard.

Once installed, the trolling motor is indexed correctly when:

1. The motor is deployed.
2. The trolling motor Control Head and Lower Unit are parallel to the centerline or keel of the boat.
3. The top of the Foot Pedal is parallel to the deck of the boat.

The following indexing instructions will align the trolling motor correctly and provide the best motor performance.

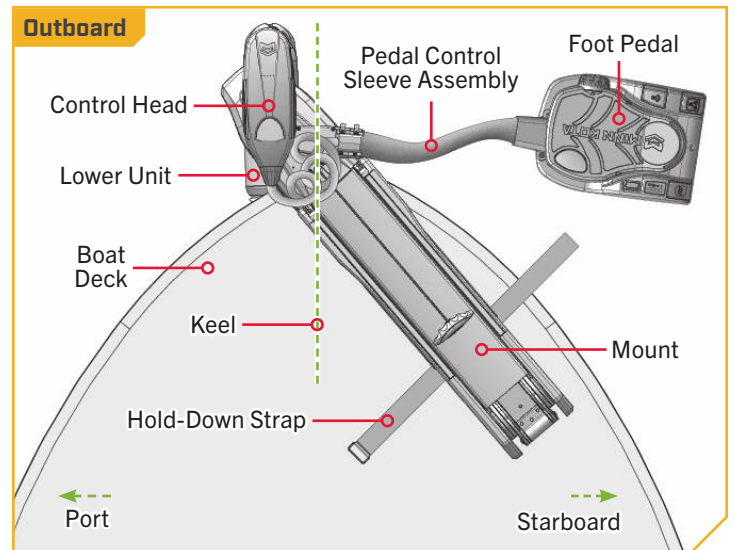
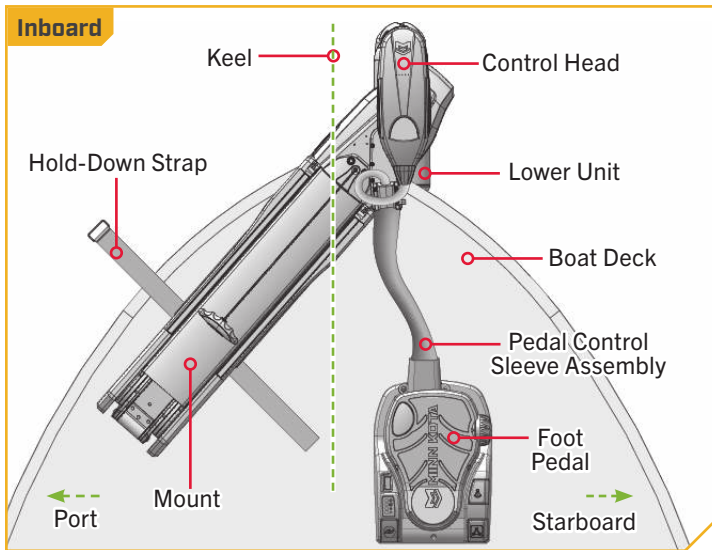

- 1**
 - a. Turn the Power Switch on the Foot Pedal "on" and steer the motor so that the Control Head is parallel to the Keel of the boat. Do this by steering the motor with the Foot Pedal, turning the motor with the remote, or manually turning the Control Head of the motor.
 - b. Leave the Control Head in the desired alignment and turn the power to the Foot Pedal "off". Then disconnect the power by removing the power cables from the battery or turning "off" the breaker if equipped.



WARNING

Ensure the motor is not connected to a power source to avoid electric shock.

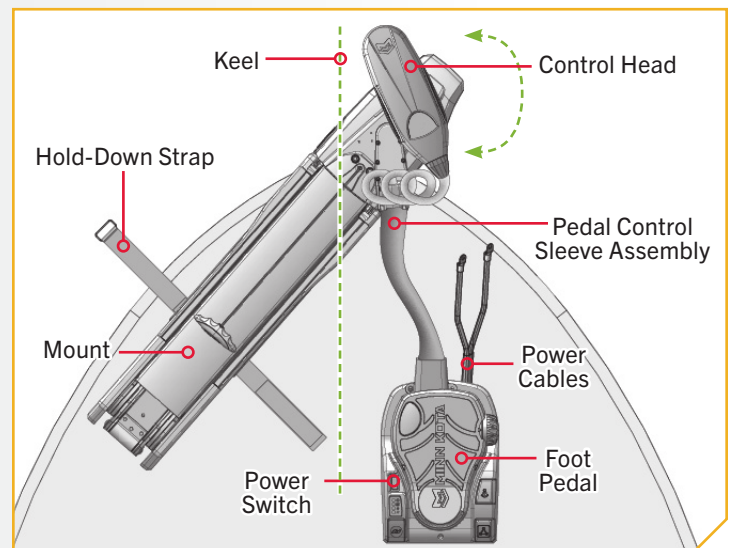

INDEXING THE MOTOR FOR A PORT INSTALLATION

2

- c. With the Control Head positioned parallel with the keel or centerline of the boat, the top of the Foot Pedal will likely not be parallel with the Boat Deck. The following instructions will correct the top position of the Foot Pedal.

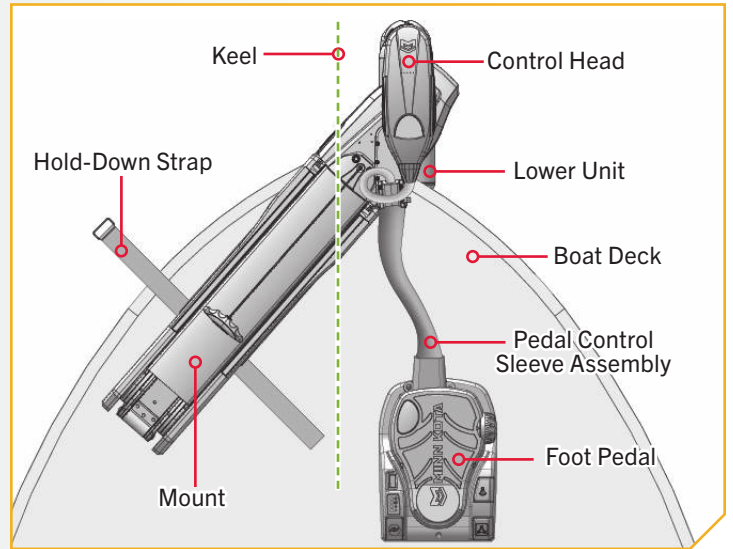
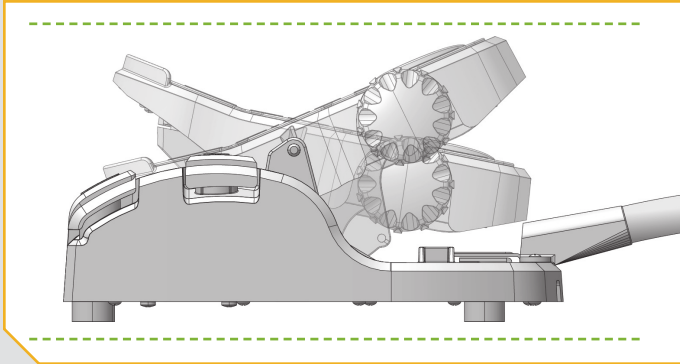

3

- d. The adjustment to the Foot Pedal is made by repositioning internal parts located where the Pedal Control Sleeve Assembly, Coil Cord, and Steering Module join. The Coil Cord Cover secures the Coil Cord in place with four screws at the end of the Pedal Control Sleeve Assembly and the top of the Steering Module.
- e. Two of the screws on the Starboard side of the Coil Cord Cover each hold a C-shaped Clip in place. The Clips retain any Ethernet or Sonar cables present. Locate the four screws holding the Coil Cord Cover in place. Using a #2 Phillips Screwdriver, remove the four Screws and the two Clips from the Coil Cord Cover and set them aside for reassembly later.

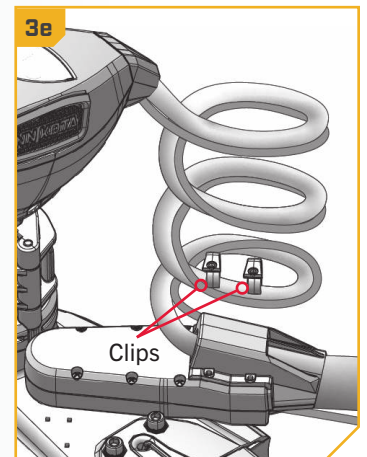
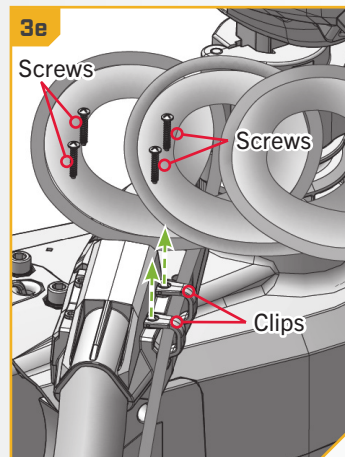
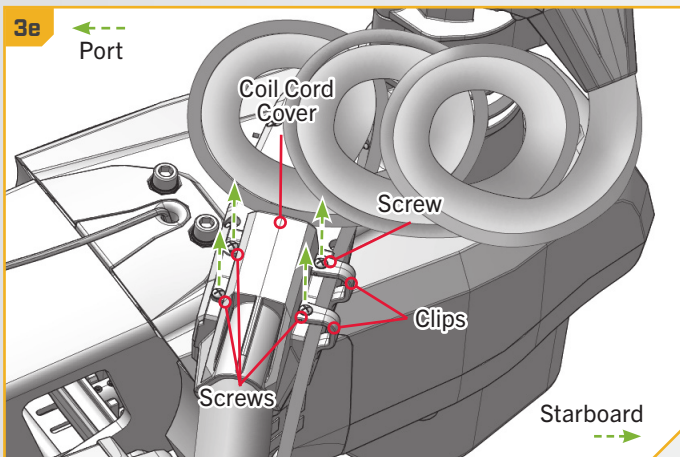
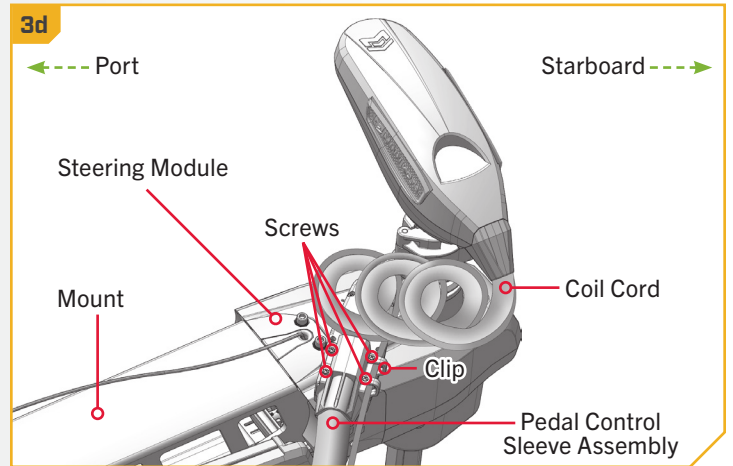

INDEXING THE MOTOR FOR A PORT INSTALLATION

4

- f. Once the two Clips and four screws are free, lift the Coil Cord Cover up and away from the Pedal Control Sleeve Assembly.
- g. Set the Coil Cord Cover aside for reassembly later.

NOTICE: Any Sonar or Ethernet Cables previously retained in the Clips can be pulled to the side to provide a clear working area around the Coil Cord Cover and Pedal Control Sleeve Assembly.

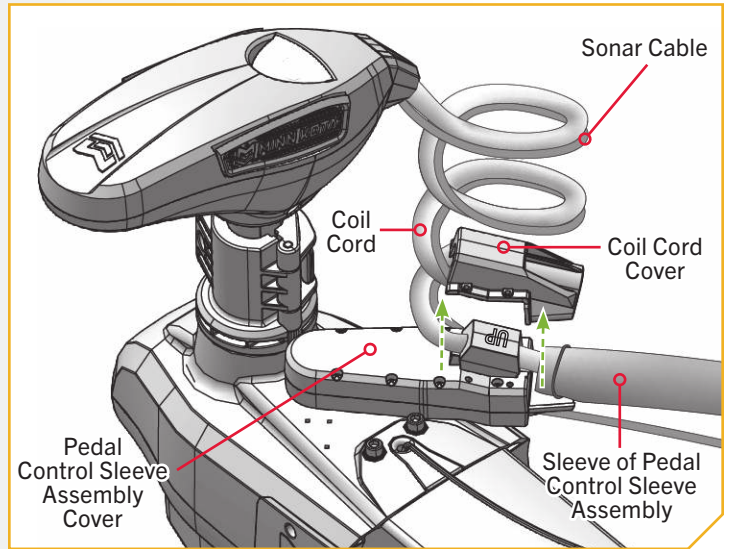

5

- h. Locate the eight screws holding the Pedal Control Sleeve Assembly Cover. Remove the screws using a #2 Phillips Screwdriver. Set the screws aside.
- i. Remove the Pedal Control Sleeve Assembly Cover by lifting it straight up. Lift the Coil Cord Assembly to the side to remove the cover if necessary.

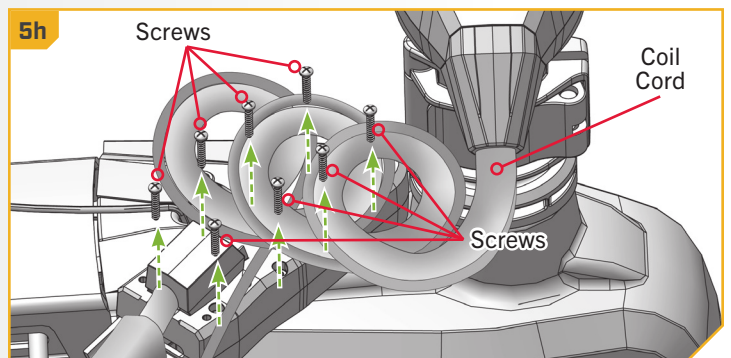
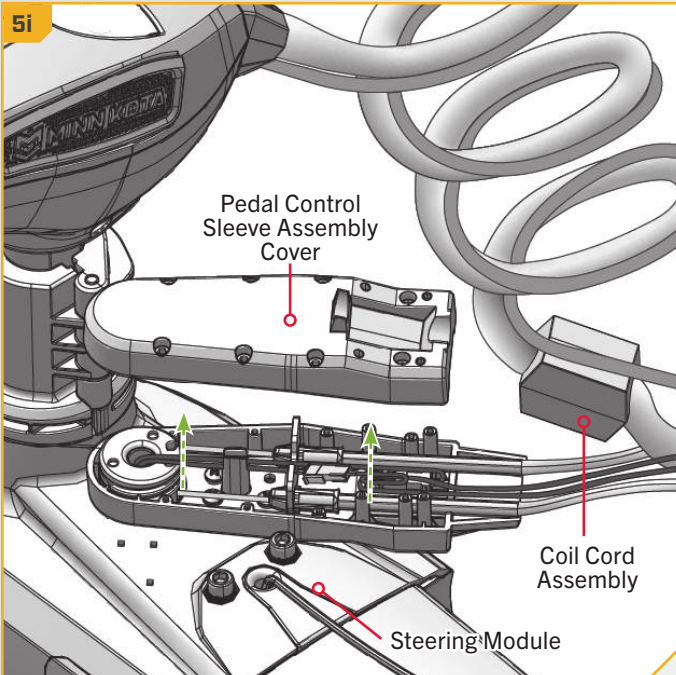
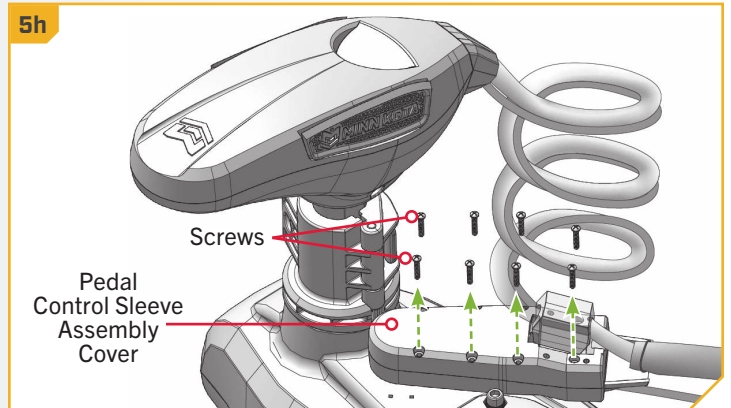

INDEXING THE MOTOR FOR A PORT INSTALLATION

6

- j. Find the two wire connections inside the Pedal Control Sleeve Assembly. One has a white Clip and the other has a black Clip. The Clips for both connections are located between the Steering Cables and are contained behind the Cable Anchor. The folded wires fit in this space, and the stacked Clips sit on each other.
- k. The wires from the Wrap Drum will be resting on a Post in the middle of the Pedal Control Sleeve Assembly. Lift the wires so they are free from the Post and straighten them. The wires should be straight from the Wrap Drum to the Cable Sleeve that is cable tied in place on the Coil Cord.

NOTICE: The connection with the black Clip contains the power wires for the steering motor inside the Steering Module. The connection with the white Clip includes the wires for the steering sensor inside the Steering Module.

- l. Disconnect both Clips.

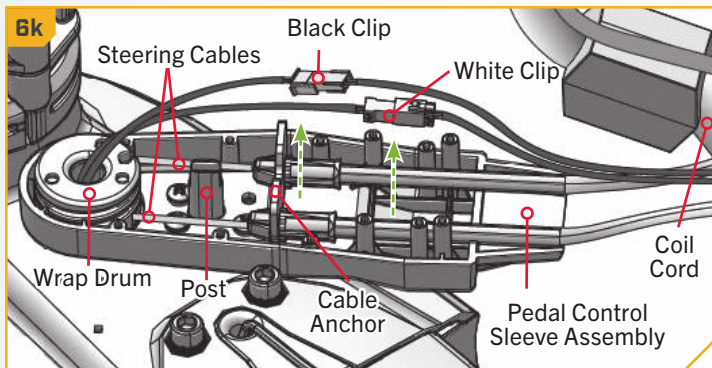
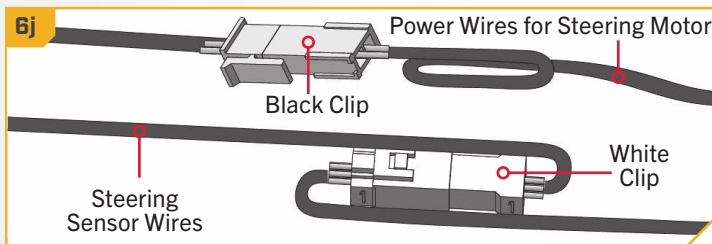
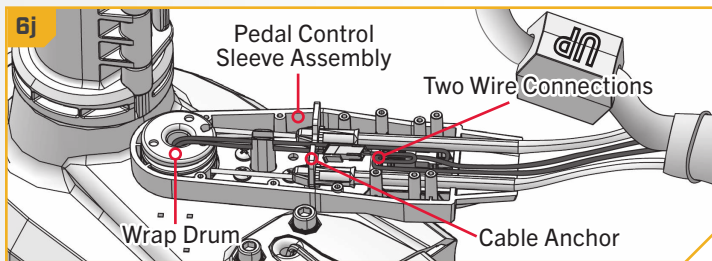

NOTICE: Use a Flat Blade Screwdriver to depress the tab on the Clips to release them.

7

- m. The black and white Clip wires from the Cable Sleeve on the Coil Cord need to be free of the Cable Anchor and out of the way to access the three Cable Anchor Screws that hold the Cable Anchor to the Steering Module. The wires that come out of the Wrap Drum must be free of obstructions to facilitate lifting the Wrap Drum later in the installation.

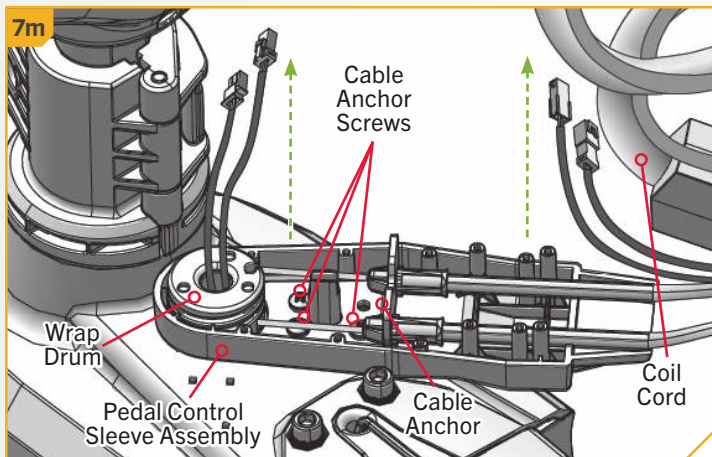

INDEXING THE MOTOR FOR A PORT INSTALLATION

8

- n. On the Foot Pedal, locate the Cable Tension Screw under the base of the Toe End of the Foot Pedal.
- o. The Cable Tension Screw holds tension on the Steering Cables. Use a #3 Phillips Screwdriver to loosen this screw. Turning the screw approximately eight rotations counterclockwise should provide enough slack in the cables to adjust. Keep track of the number of screw rotations so it can be re-tightened accordingly later.
- p. Loosen the Cable Tension Screw just enough so that the Steering Cables can be pinched together between the Cable Anchor and Wrap Drum.

CAUTION

Over-loosening the Cable Tension Screw may cause the cables to disengage from the Wrap Drum.

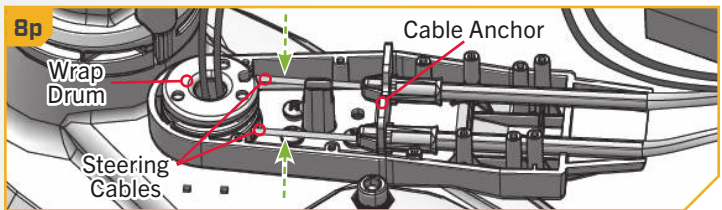
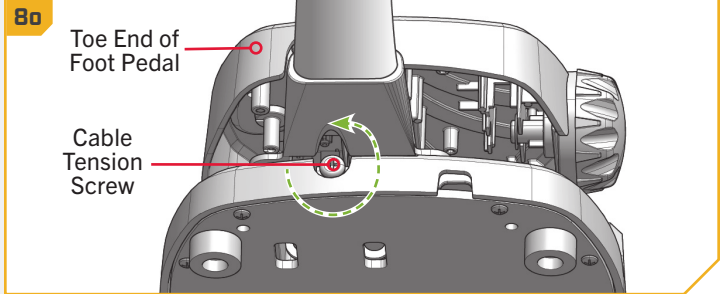

NOTICE: The Steering Cables are fed through the Cable Anchor and wound around the Wrap Drum. The right-side Cable is the shorter cable and begins winding on the Wrap Drum from the top down. The left-side Cable is the longer cable and begins winding on the Wrap Drum from the bottom up.

9

- q. Once the Steering Cables are loose, take a #2 Phillips Screwdriver and remove the three Cable Anchor Screws that hold the Cable Anchor in place on the Steering Module. Set the screws aside.
- r. With the three screws holding the Cable Anchor removed, the Cable Anchor and bottom of the Pedal Control Sleeve Assembly can move freely around the Cable Spline Gear. The Wrap Drum sits on the Cable Spline Gear.

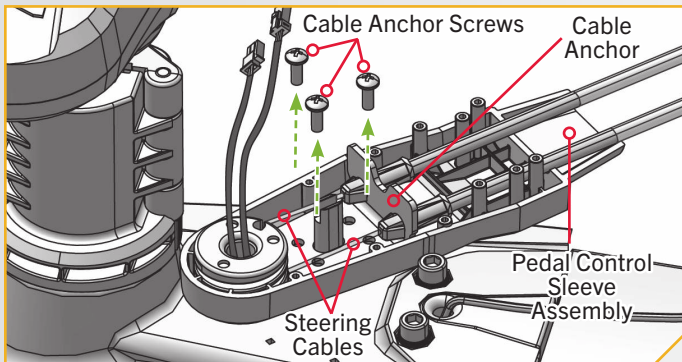
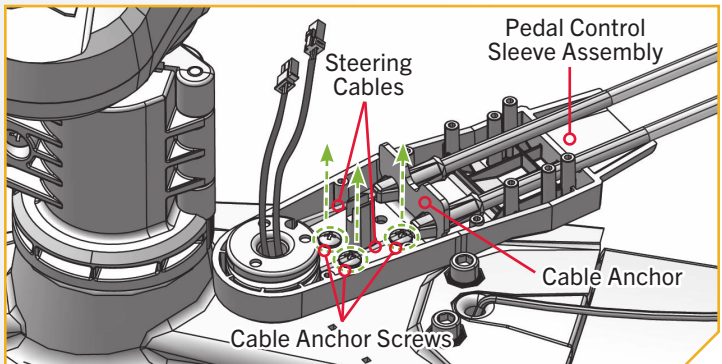

INDEXING THE MOTOR FOR A PORT INSTALLATION

10

- s. Once the Cable Tension Screw on the Foot Pedal is loosened, use a Flat-blade Screwdriver to pry the Wrap Drum straight off the Cable Gear. Lift until the Wrap Drum is free of the Cable Spline Gear.

CAUTION

Ensure that the Steering Cables remain on the Wrap Drum while disengaged from the Cable Spline Gear. The Steering Cables must follow the grooves on the Wrap Drum so that they do not become intertwined or pop off. Ensure the wires are not damaged when lifting the Wrap Drum.

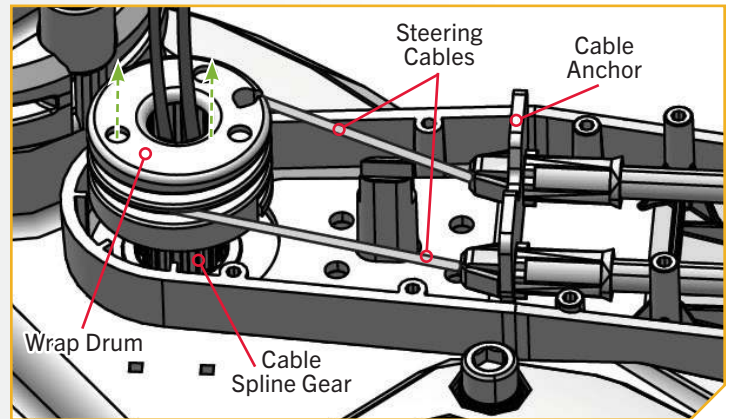
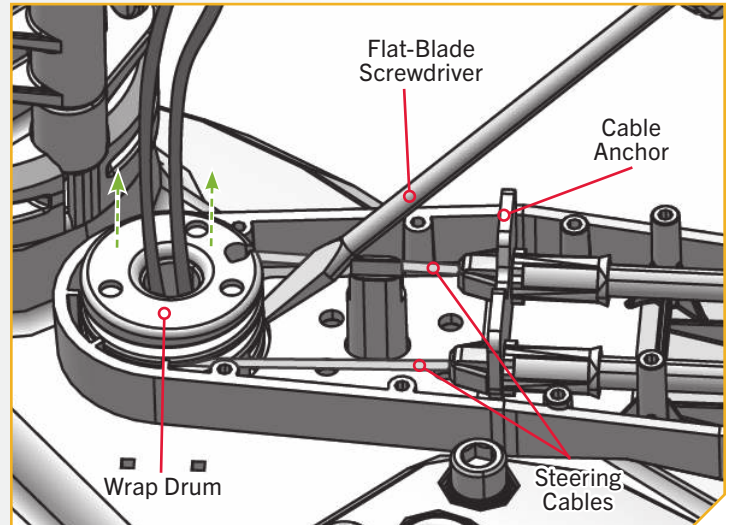

INDEXING THE MOTOR FOR A PORT INSTALLATION

11

- t. While holding the Wrap Drum just above the Cable Spline Gear, and maintaining tension on the Steering Cables, carefully rotate the Wrap Drum right or left until the top of the Foot Pedal is parallel with the deck of the boat. The proper position of the Wrap Drum will locate the Drum Anchors for each Steering Cable equidistant from the mid-line of the Cable Anchor, where it is secured to the Steering Module.

CAUTION

Do not make this adjustment by applying pressure to the Foot Pedal. Rotate the Wrap Drum manually and use the Foot Pedal position as a guide to indicate the proper position of the Wrap Drum.

- u. Once the Foot Pedal is at the desired position, align the Wrap Drum with the nearest tooth on the splined shaft of the Cable Spline Gear. Press the Wrap Drum securely, so it is seated on top of the gear. At this point, the head of the motor should be parallel with the Boat Keel, and the top of the Foot Pedal should be parallel with the Boat Deck.

NOTICE: The top of the Wrap Drum has rounded and smooth edges. The bottom of the Wrap Drum is flat, and the teeth that engage the Cable Spline Gear are visible in the center.

CAUTION

If the Wrap Drum becomes unintentionally disengaged from the Cable Gear, the Steering Cables can become unwound and needs to be reassembled correctly for proper operation.

NOTICE: When seating the Wrap Drum, make sure not to pinch the motor power or steering sensor wires between the Wrap Drum and the Cable Spline Gear.

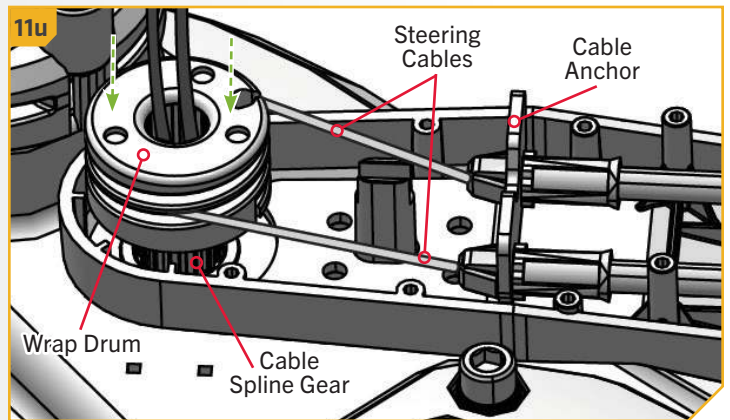
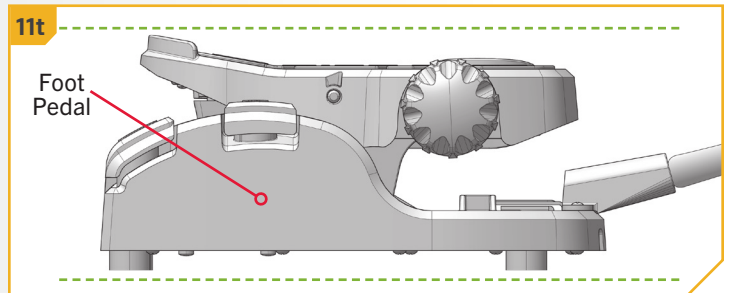
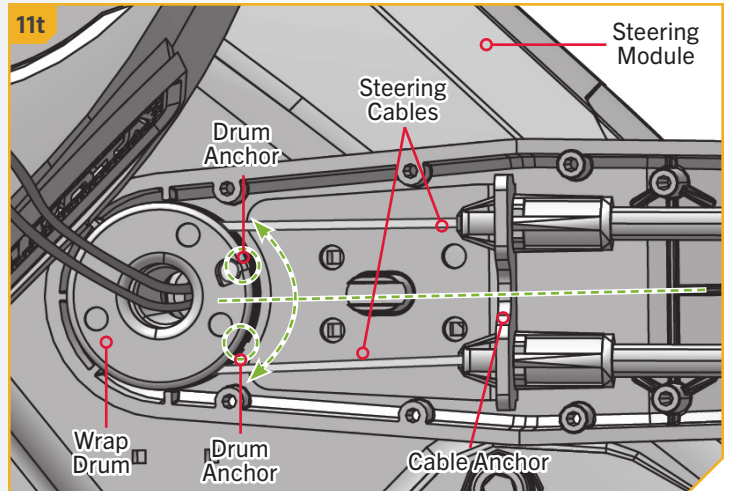

NOTICE: When adjusting the Wrap Drum, the Cable Anchor and the bottom of the Pedal Control Sleeve Assembly will be loose. The pieces are loose to help facilitate the rotation and the tension on the cables for the adjustment.

INDEXING THE MOTOR FOR A PORT INSTALLATION

12

- v. Take the three Cable Anchor Screws that hold the Cable Anchor to the Steering Module and replace them using a #2 Phillips Screwdriver. The screws should pass through the Cable Anchor and the bottom of the Pedal Control Sleeve Assembly and into the Steering Module. Tighten the Cable Anchor Screws to 30 in-lbs.

NOTICE: The Cable Anchor and the Pedal Control Sleeve Assembly contain four holes to secure the assembly to the Steering Module, but only three holes are used. Ensure the screws are placed in the same three holes to replace the Pedal Control Sleeve Assembly and Cable Anchor that were uninstalled in an earlier step. The hole that should not be used will not have a threaded hole into the Steering Module to secure the Cable Anchor Screw. For trolling motors mounted on the Port side of the Boat Deck, this hole will be the furthest inboard toward the Keel and align inboard from the Steering Module.

- w. Once the screws are in place, return to the Foot Pedal.

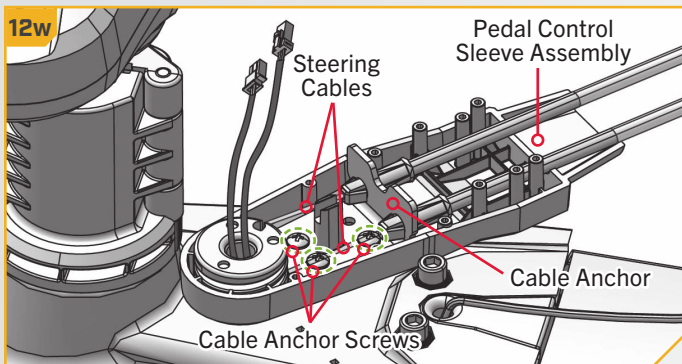
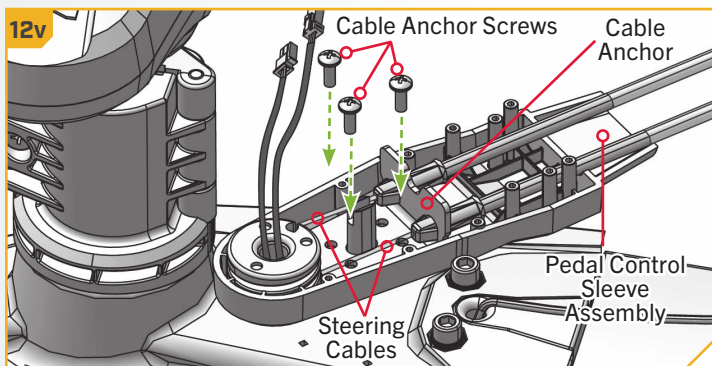
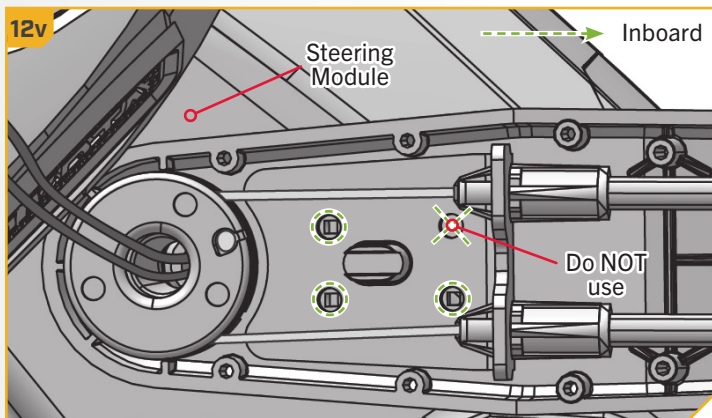

13

- x. Using a #3 Phillips Screwdriver, tighten the Cable Tension Screw located at the base of the Toe End of the Foot Pedal to 10 - 12 in-lbs until the Steering Cables are under tension, or re-tighten the Cable Tension Screw the same number of turns it was loosened to at the beginning of the process.

CAUTION

Do not over-tighten the Cable Tension Screw, as excessive tension will cause damage to the unit.

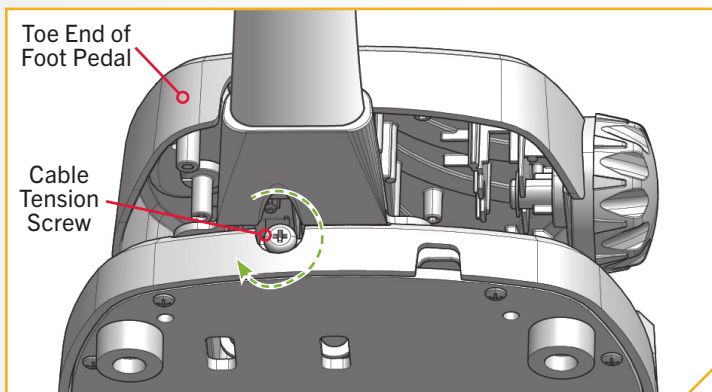

INDEXING THE MOTOR FOR A PORT INSTALLATION

14

- y. The wires from the Steering Module go through the center of the Cable Spline Gear and the Wrap Drum. The mated connection to these wires enters the Pedal Control Sleeve Assembly from the Coil Cord. Match the wire with the white Clip with the corresponding wire with the white Clip and press the connection together.
- z. Do the same for the wires with the black Clip.

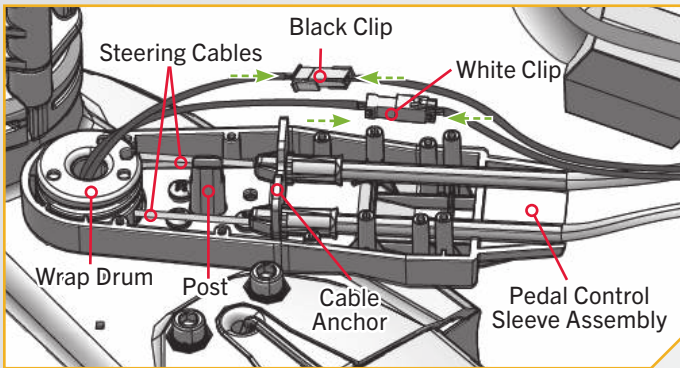
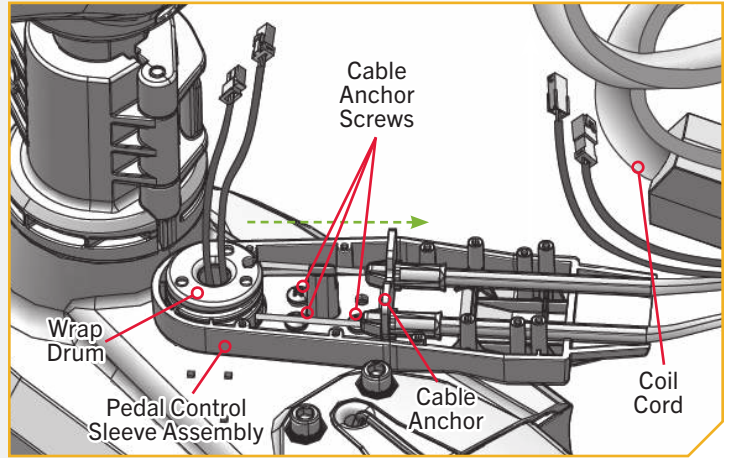

15

- aa. With the Clips secured, guide the wires from the Wrap Drum straight and position them towards the Coil Cord away from the Wrap Drum.
- ab. To cleanly place the wires inside the Pedal Control Sleeve Assembly, start with the wire with the white Clip. Place the wire with the white Clip in the groove of the Post on the Cable Anchor. Then gently guide the wire past the "V" groove of the Cable Anchor.
- ac. Take the white Clips and gently bend the wires so that the slack in the wires forms a loose "S" shape. Guide it to the side of the Cable Anchor where the Steering Cables are coated with a black sleeve away from the Wrap Drum. Place the white Clip and the "S" shaped wire between the black sleeve on the Cables.
- ad. Repeat the process for the wire with the black Clip. Shape the wire with the black Clip into a small loop rather than an "S" shape.

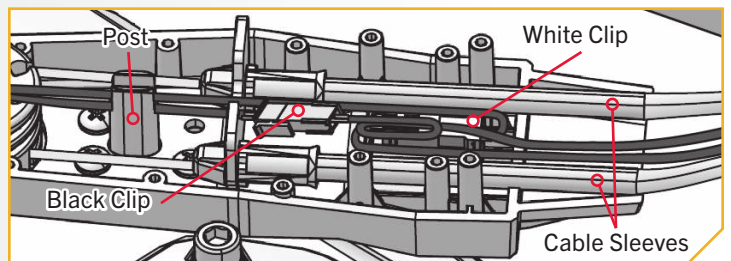
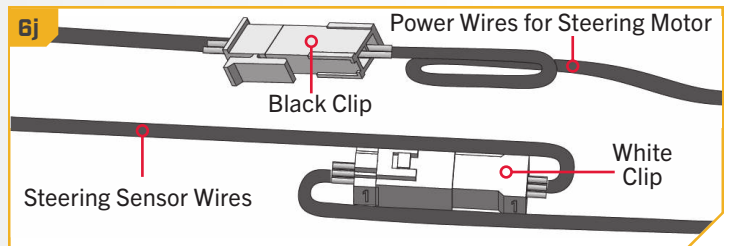
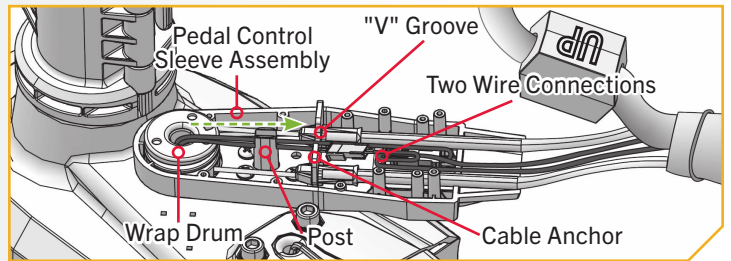

NOTICE: Ensure the wires remain in the Post when complete.

INDEXING THE MOTOR FOR A PORT INSTALLATION

16

- ae. Ensure the wires are seated and will not be pinched or kinked when the Pedal Control Sleeve Assembly Cover is replaced.
- af. Take the Pedal Control Sleeve Assembly Cover and rotate it so that the rounded end is over the Wrap Drum. Place the cover on the Pedal Control Sleeve Assembly.
- ag. Take the screws and place one in each of the eight Mounting Holes with recessed embossing. Use a #2 Phillips Screwdriver and tighten to 13 in.-lbs.

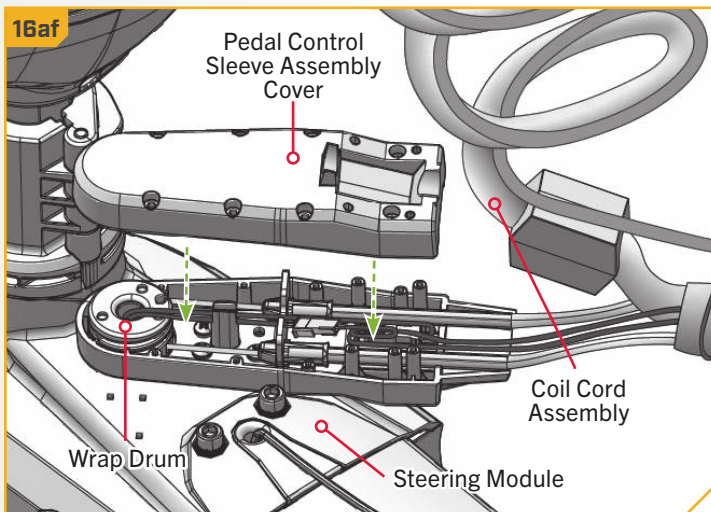
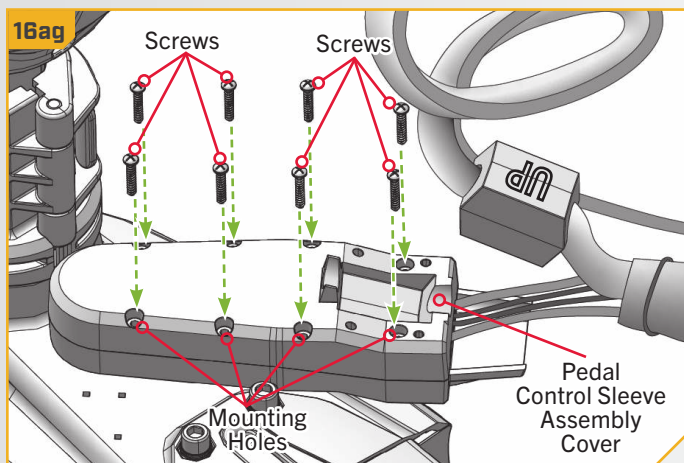

17

- ah. The Coil Cord Assembly is covered by a Sleeve that joins the wires and cables that exit the Pedal Control Sleeve Assembly and extends to the Foot Pedal. The Sleeve is secured with a Cable Tie, which joins with the Coil Cord.
- ai. Adjust the Coil Cord so that the Sleeve with the Cable Tie sits into the bottom recess of the Pedal Control Sleeve Assembly. To do this, rotate the main part of the Coil Cord Assembly by the Molded Block. The Molded Block is rectangular in shape and should be rotated so that the word "UP" molded into the block is facing upward. Press the Molded Block into the Pedal Control Sleeve Assembly Cover until seated.

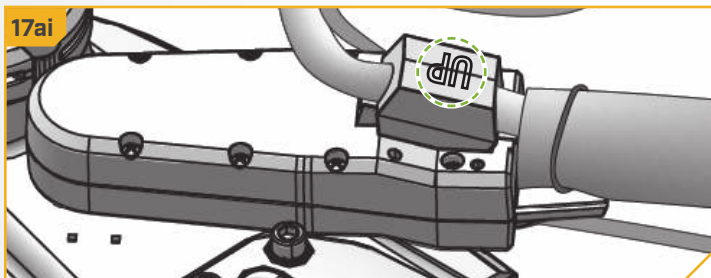
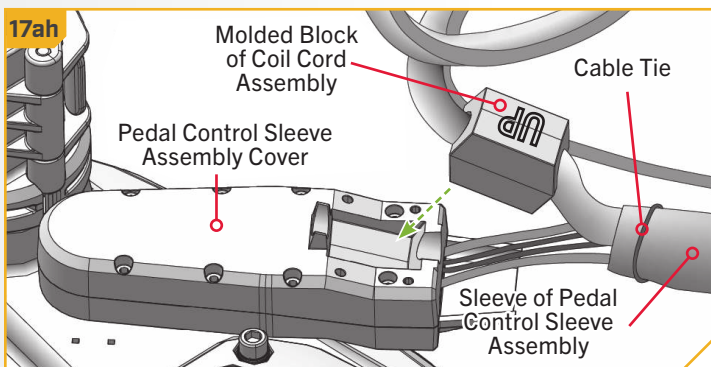

INDEXING THE MOTOR FOR A PORT INSTALLATION

18

- aj. The Molded Block of the Coil Cord Assembly should be seated, and the Cable Tie and Sleeve should be secured in the recess at the bottom of the Pedal Control Sleeve Assembly. Take the Coil Cord Cover and replace it on the Pedal Control Sleeve Assembly and Molded Block. The stepped design of the Cover fits around the back of the Pedal Control Sleeve Assembly. Be sure that the Coil Cord exits the assembly and that the Sleeve and Cable tie below it are in place. The wires and Sleeve should be captured but not pinched between the Cover and Sleeve.

NOTICE: If present, do not capture the Sonar or Ethernet Cables in the Coil Cord Cover. Re-capture these cables that run along the side of the Coil Cord Cover during the re-installation of the Clips.

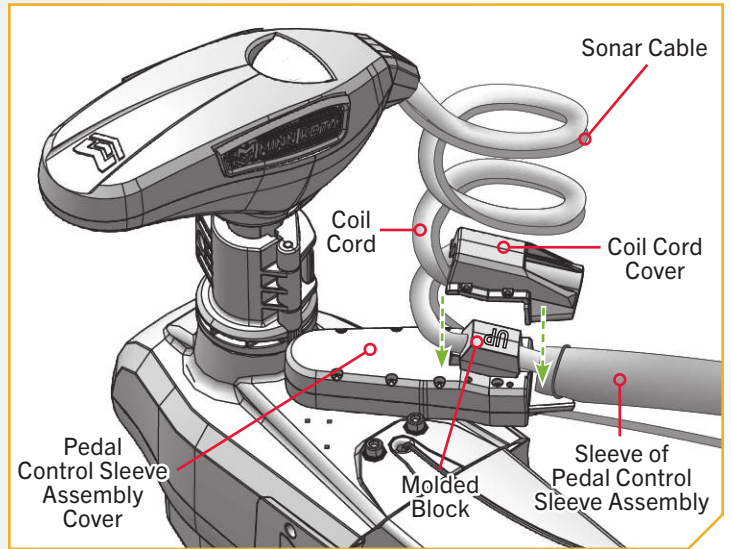

19

- ak. Take the four screws and two Clips that were removed at the beginning of the installation and replace them. The Clips should be installed with the two screws on the starboard side of the motor for a standard installation. When installing the Clips, they should be rotated so that the opening is downward toward the Boat Deck. Replace the two screws that hold the Clips first so that they first go through the Coil Cord Cover and into the Pedal Control Sleeve Assembly. Use a #2 Phillips Screwdriver. If present, capture the Sonar or Ethernet Cables into the Clips when they are reinstalled.
- al. The screws that do not hold Clips on the Port-side of the Mount can be installed directly into the Coil Cord Cover and Pedal Control Sleeve Assembly. Tighten all four screws to 13 in-lbs.

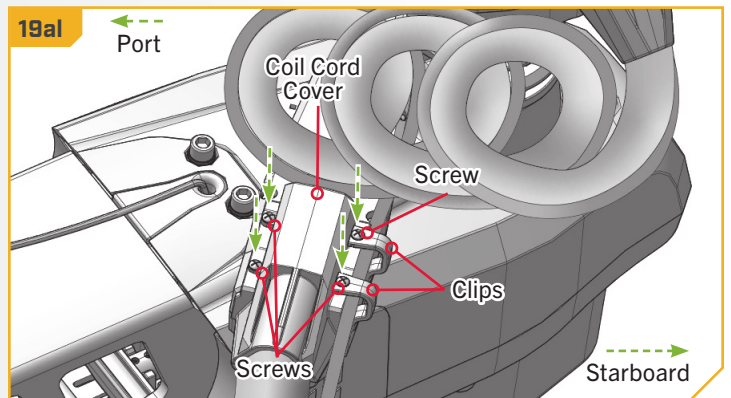
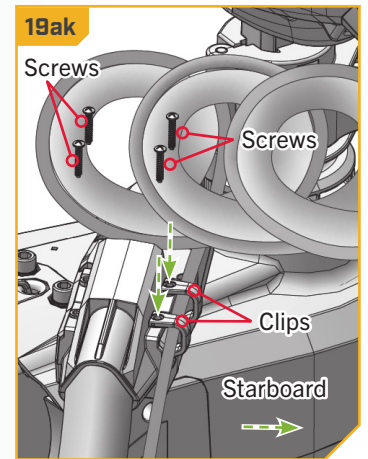
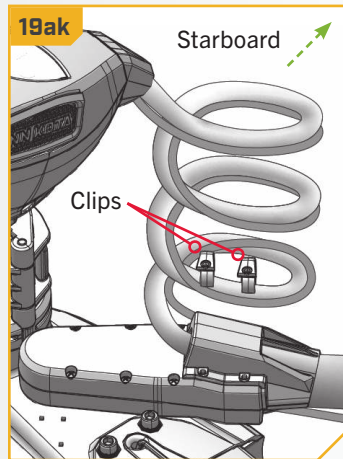

ROTATE THE PEDAL CONTROL SLEEVE ASSEMBLY FOR A STARBOARD MOUNT

› Rotate the Pedal Control Sleeve Assembly for a Starboard Mount

By default, the Pedal Control Sleeve Assembly is factory set so that when your Ultrex QUEST is installed on the port side of your boat, the Pedal Control Sleeve Assembly points inboard. Should you choose to install your Ultrex QUEST on the Starboard side of your boat, it is recommended that the default mounting location be changed so that the Pedal Control Sleeve Assembly points inboard.

Once installed, the trolling motor is indexed correctly when:

1. The motor is deployed.
2. The trolling motor Control Head and Lower Unit align with the centerline or keel of the boat.
3. The top of the Foot Pedal is parallel to the deck of the boat.

Use the following instructions to change the mounting location of the Pedal Control Sleeve Assembly on the Steering Module to point inboard, and properly align the Control Head of the motor. If your motor was installed on the Port side of the boat, please disregard these instructions and see the Indexing the "Motor for a Port Installation" section of this manual.

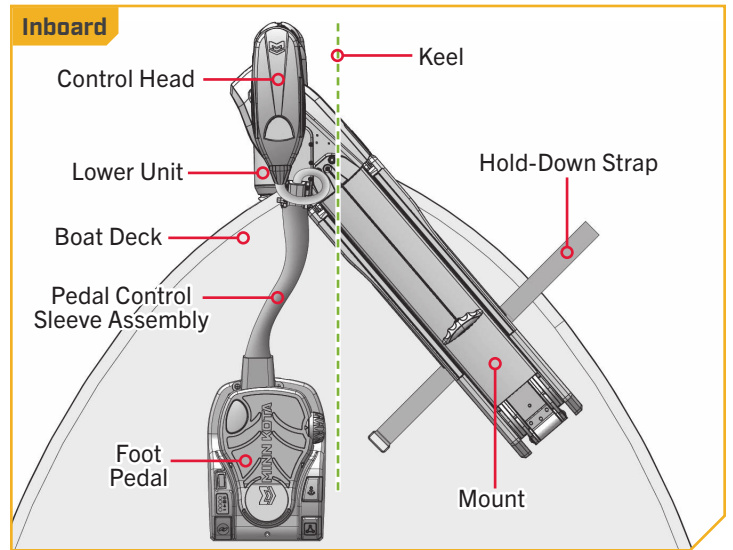
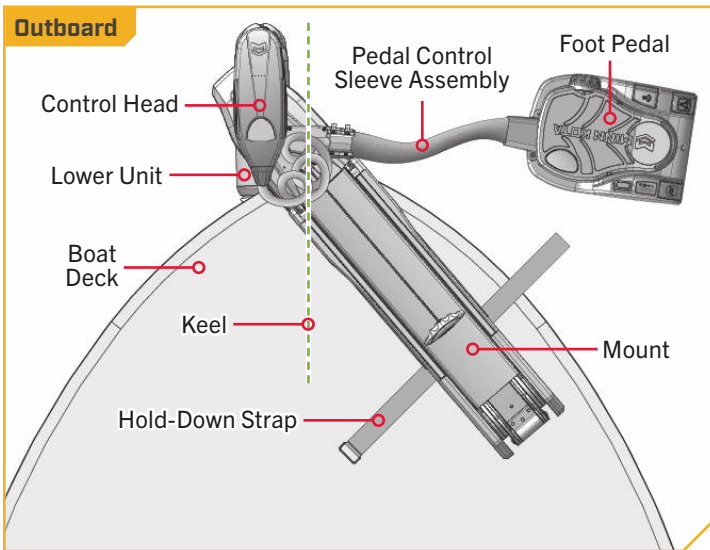

- 1**
 - a. Turn the Power Switch on the Foot Pedal "on" and steer the motor so that the Control Head is in line with the keel of the boat. Do this by steering the motor with the Foot Pedal, turning the motor with the remote, or manually turning the Control Head of the motor.
 - b. Leave the Control Head in the desired alignment and turn the power to the Foot Pedal "off". Then disconnect the power by removing the power cables from the battery or turning "off" the breaker if equipped.

WARNING

Ensure the motor is not connected to a power source to avoid electric shock.

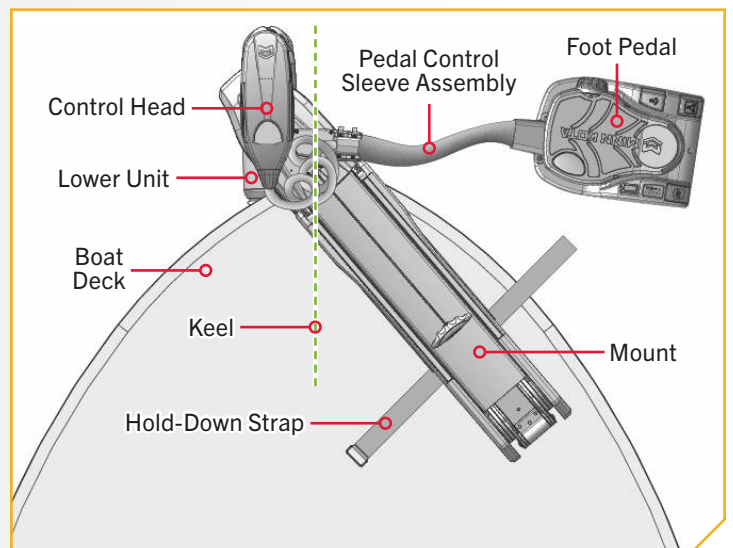

ROTATE THE PEDAL CONTROL SLEEVE ASSEMBLY FOR A STARBOARD MOUNT

2

- c. With the Control Head positioned parallel with the keel or centerline of the boat, the top of the Foot Pedal will likely not be parallel with the Boat Deck. The following instructions will correct the top position of the Foot Pedal.

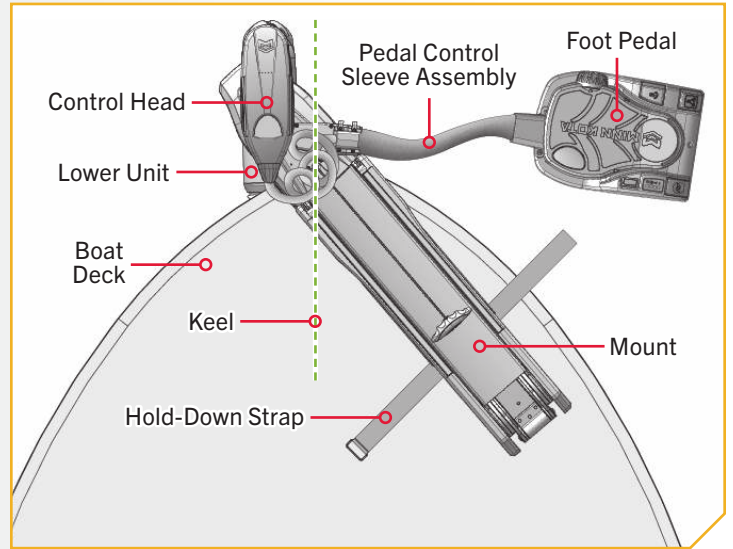
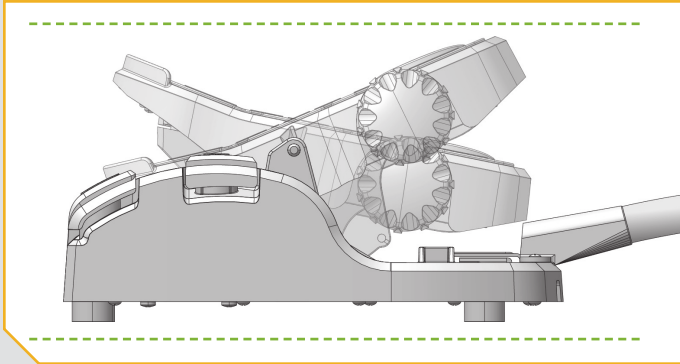

3

- d. The adjustment to the Foot Pedal and rotating the Pedal Control Sleeve Assembly is made by repositioning internal parts located where the Pedal Control Sleeve Assembly, Coil Cord, and Steering Module join. The Coil Cord Cover secures the Coil Cord in place with four screws at the end of the Pedal Control Sleeve Assembly and the top of the Steering Module.
- e. Two of the screws on the Starboard side of the Coil Cord Cover each hold a C-shaped Clip in place. The Clips retain any Ethernet or Sonar cables present. Locate the four screws holding the Coil Cord Cover in place. Using a #2 Phillips Screwdriver, remove the four Screws and the two Clips from the Coil Cord Cover and set them aside for reassembly later.

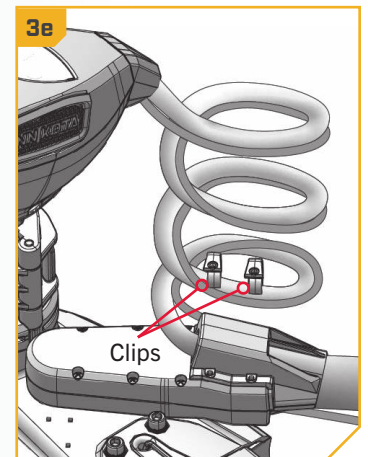
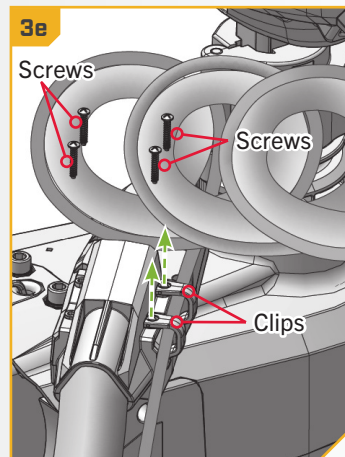
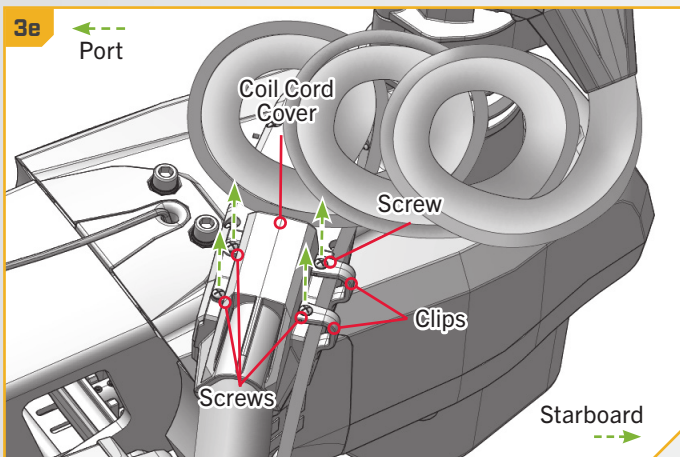
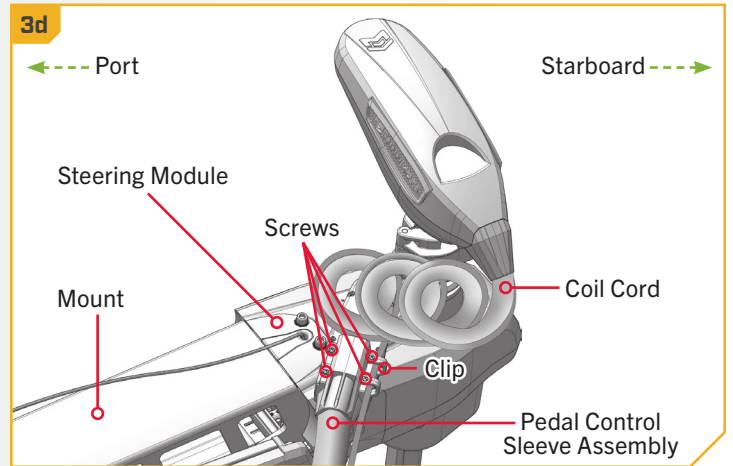

ROTATE THE PEDAL CONTROL SLEEVE ASSEMBLY FOR A STARBOARD MOUNT

4

- f. Once two Clips and four screws are free, lift the Coil Cord Cover up and away from the Pedal Control Sleeve Assembly.
- g. Set the Coil Cord Cover aside for reassembly later.

NOTICE: Any Sonar or Ethernet Cables previously retained in the Clips can be pulled to the side to provide a clear working area around the Coil Cord Cover and Pedal Control Sleeve Assembly.

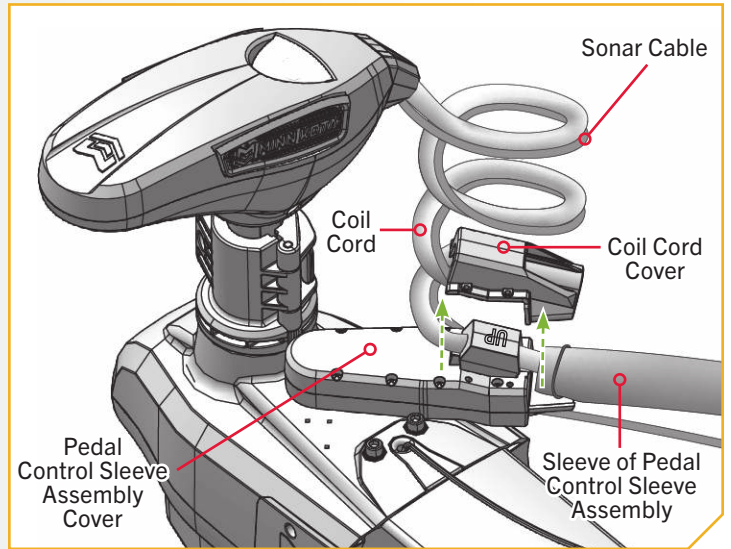

5

- h. Locate the eight screws holding the Pedal Control Sleeve Assembly Cover. Remove the screws using a #2 Phillips Screwdriver. Set the screws aside.
- i. Remove the Pedal Control Sleeve Assembly Cover by lifting it straight up. Lift the Coil Cord Assembly to the side to remove the cover if necessary.

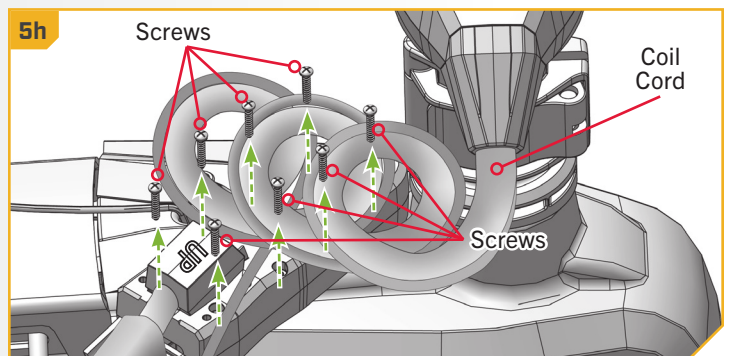
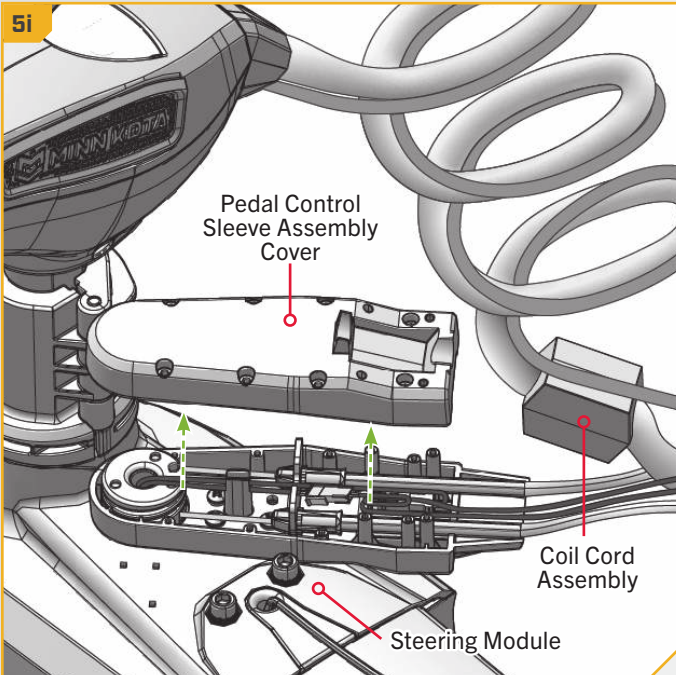
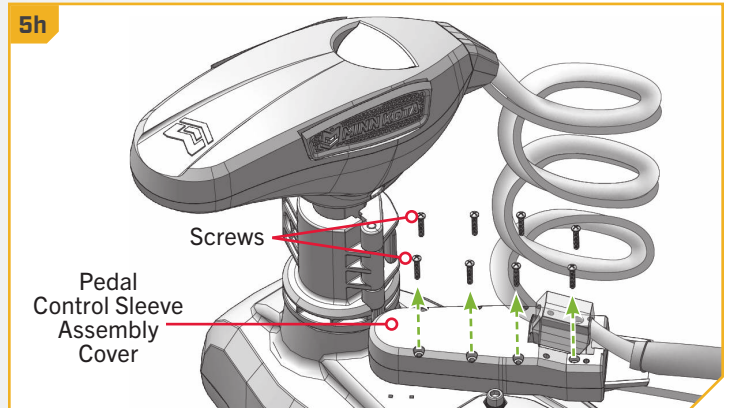

ROTATE THE PEDAL CONTROL SLEEVE ASSEMBLY FOR A STARBOARD MOUNT

6

- j. Find the two wire connections inside the Pedal Control Sleeve Assembly. One has a white Clip and the other has a black Clip. The Clips for both connections are located between the Steering Cables and are contained behind the Cable Anchor. The folded wires fit in this space, and the stacked Clips sit on each other.
- k. The wires from the Wrap Drum will be resting on a Post in the middle of the Pedal Control Sleeve Assembly. Lift the wire so they are free from the Post and straighten them. The wires should be straight from the Wrap Drum to the Cable Sleeve that is cable tied in place on the Coil Cord.

NOTICE: The connection with the black Clip contains the power wires for the steering motor inside the Steering Module. The connection with the white Clip includes the wires for the steering sensor inside the Steering Module.

- l. Disconnect both Clips.

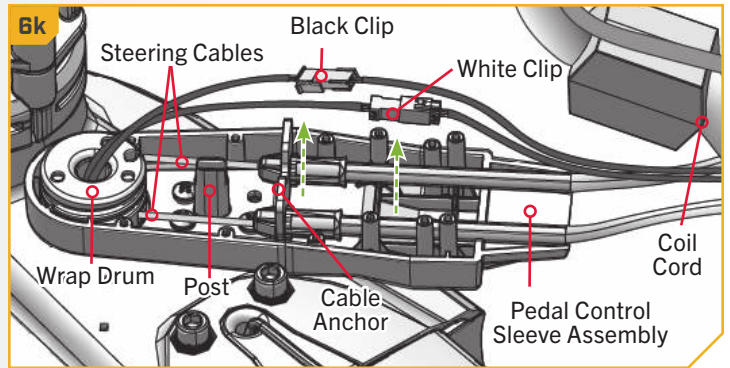
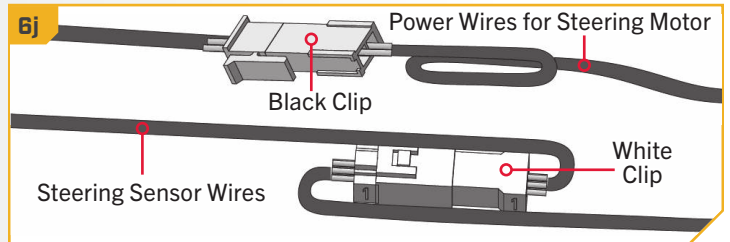
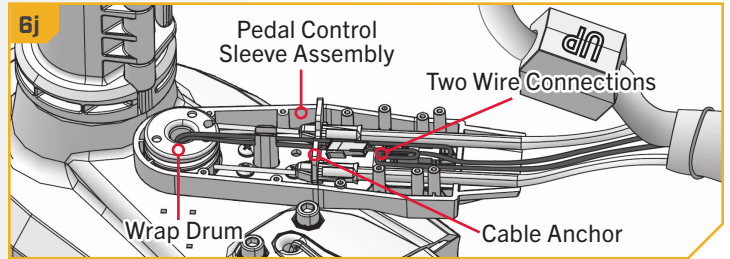

NOTICE: Use a Flat Blade Screwdriver to depress the tabs on the Clips to release them.

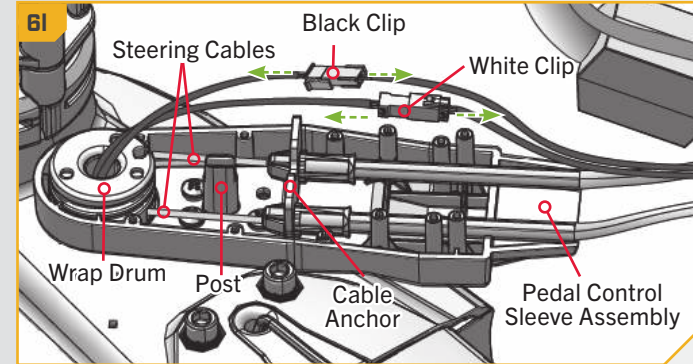

7

- m. The black and white Clip wires from the Cable Sleeve on the Coil Cord need to be free of the Cable Anchor and out of the way to access the three Cable Anchor Screws that hold the Cable Anchor to the Steering Module. The wires that come out of the Wrap Drum must be free of obstructions to facilitate lifting the Wrap Drum later in the installation.

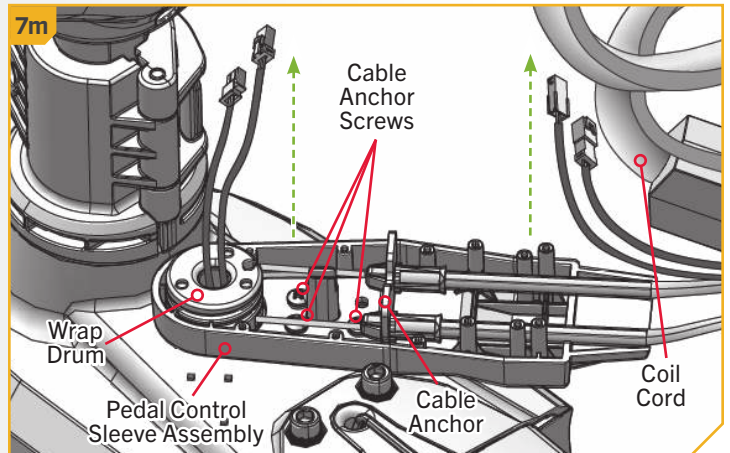

ROTATE THE PEDAL CONTROL SLEEVE ASSEMBLY FOR A STARBOARD MOUNT

8

- n. On the Foot Pedal, locate the Cable Tension Screw under the base of the Toe End of the Foot Pedal.
- o. The Cable Tension Screw holds tension on the Steering Cables. Use a #3 Phillips Screwdriver to loosen this screw. Turning the screw approximately fifteen rotations counterclockwise should provide enough slack in the cables to adjust. Keep track of the number of screw rotations so it can be re-tightened accordingly later.
- p. Loosen the Cable Tension Screw just enough so that the Steering Cables can be pinched together between the Cable Anchor and Wrap Drum.

CAUTION

Over-loosening the Cable Tension Screw may cause the cables to disengage from the Wrap Drum.

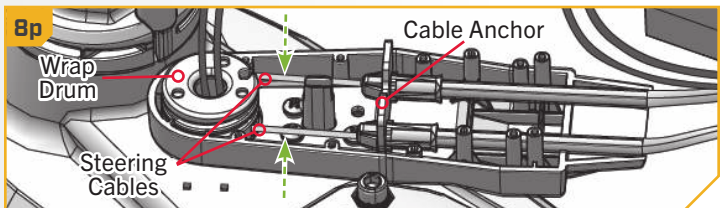
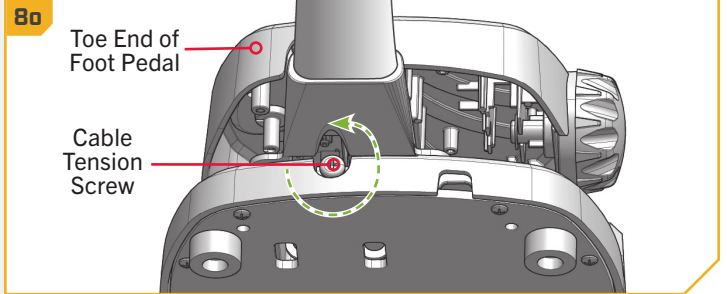

NOTICE: The Steering Cables are fed through the Cable Anchor and wound around the Wrap Drum. The right-side Cable is the shorter cable and begins winding on the Wrap Drum from the top down. The left-side Cable is the longer cable and begins winding on the Wrap Drum from the bottom up.

9

- q. Once the Steering Cables are loose, take a #2 Phillips Screwdriver and remove the three Cable Anchor Screws that hold the Cable Anchor in place on the Steering Module. Set the screws aside.
- r. With the three screws holding the Cable Anchor removed, the Cable Anchor and bottom of the Pedal Control Sleeve Assembly can move freely around the Cable Spline Gear. The Wrap Drum sits on the Cable Spline Gear.

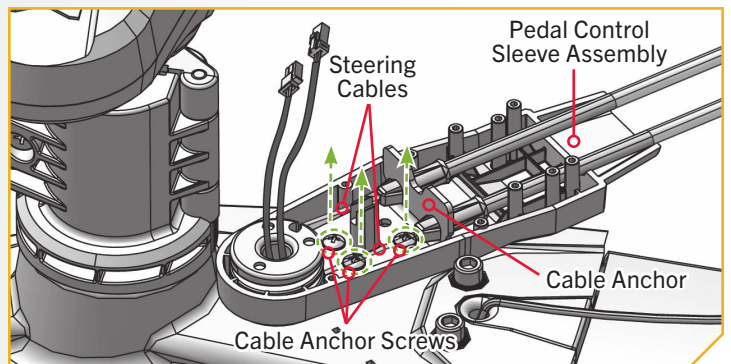
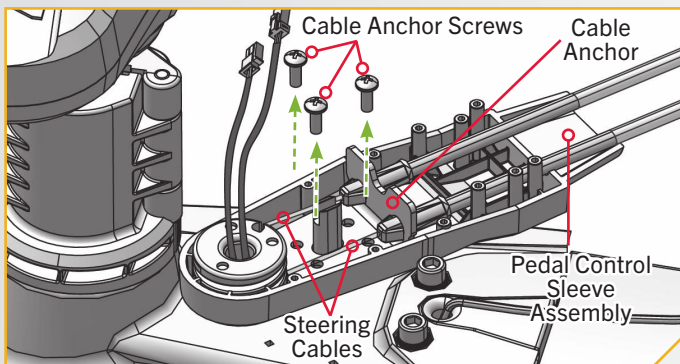

ROTATE THE PEDAL CONTROL SLEEVE ASSEMBLY FOR A STARBOARD MOUNT

10

- s. Once the Cable Tension Screw on the Foot Pedal is loosened, use a Flat-blade Screwdriver to pry the Wrap Drum straight off the Cable Gear. Lift until the Wrap Drum is free of the Cable Spline Gear.

CAUTION

Ensure that the Steering Cables remain on the Wrap Drum while disengaged from the Cable Spline Gear. The Steering Cables must follow the grooves on the Wrap Drum so that they do not become intertwined or pop off. Ensure the electric wires are not damaged when lifting the Wrap Drum.

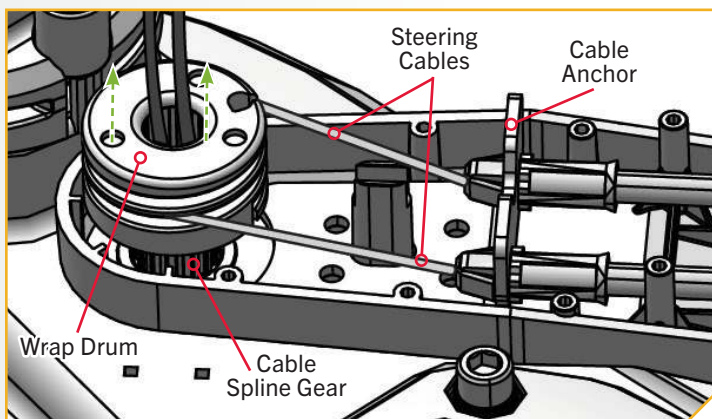
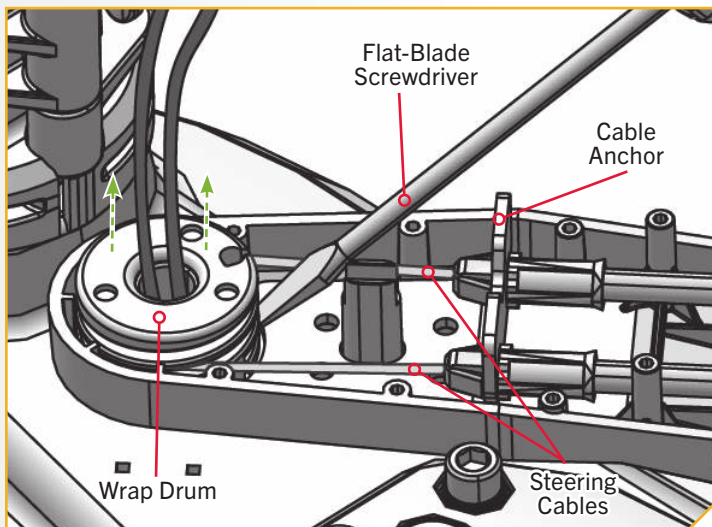

ROTATE THE PEDAL CONTROL SLEEVE ASSEMBLY FOR A STARBOARD MOUNT

11

- t. While holding the Wrap Drum just above the Cable Spline Gear, and maintaining tension on the Steering Cables, carefully rotate the Wrap Drum, Cable Anchor, and bottom of the Pedal Control Sleeve Assembly inboard towards the Port side of the boat. Rotate the pieces, keeping the Wrap Drum centered over the Cable Spline Gear. The Cable Anchor and bottom of the Pedal Control Sleeve Assembly contain holes that align to install the Cable Anchor Screws. The pieces are rotated to the correct position when the Mounting Holes in the Cable Anchor and Pedal Control Sleeve Assembly align with the threaded holes on the Port-facing side of the Steering Module.

NOTICE: When rotating the Pedal Control Sleeve Assembly, Cable Anchor, and Wrap Drum, ensure the pieces are lifted high enough off the Steering Module to avoid hitting the Allen Screws that secure the Steering Module to the Mount.

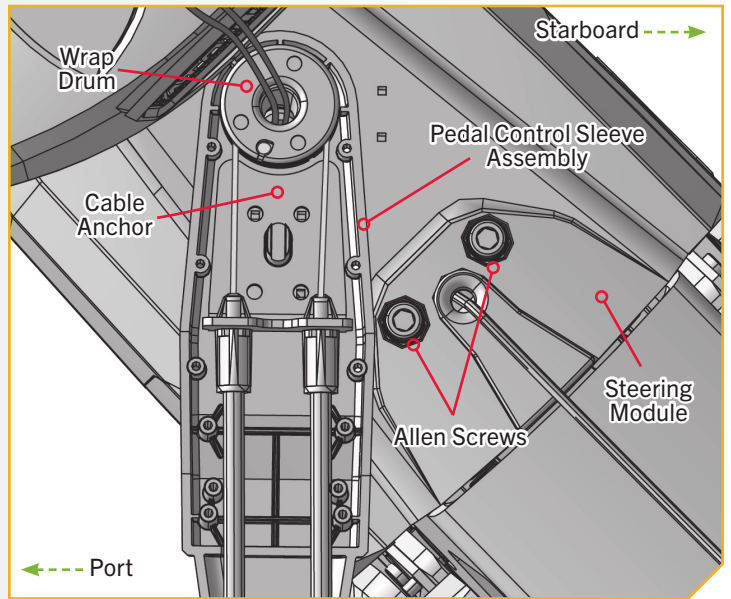
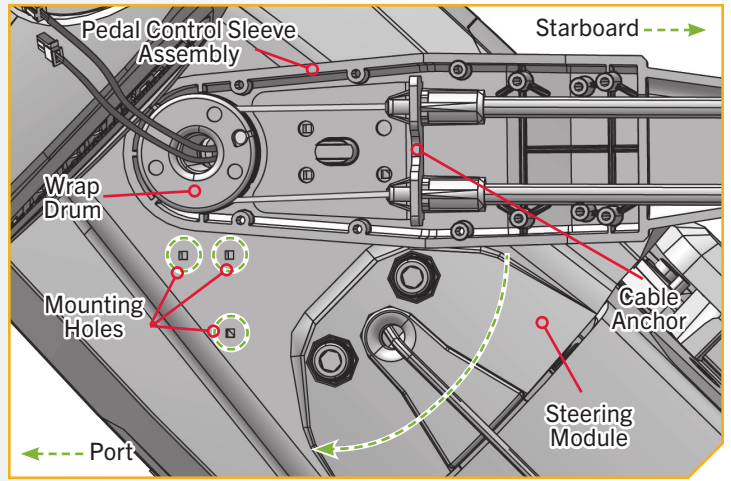

ROTATE THE PEDAL CONTROL SLEEVE ASSEMBLY FOR A STARBOARD MOUNT

12

- u. While holding only the Wrap Drum just above the Cable Spline Gear, and maintaining tension on the Steering Cables, carefully rotate the Wrap Drum right or left until the top of the Foot Pedal is parallel with the deck of the boat. The proper position of the Wrap Drum will locate the Drum Anchors for each Steering Cable equidistant from the mid-line of the Cable Anchor, where it is secured to the Steering Module.

CAUTION

Do not make this adjustment by applying pressure to the Foot Pedal. Rotate the Wrap Drum manually and use the Foot Pedal position as a guide to indicate the proper position of the Wrap Drum.

- v. Once the Foot Pedal is at the desired position, align the Wrap Drum with the nearest tooth on the Splined Shaft of the Cable Spline Gear. Press the Wrap Drum securely, so it is seated on top of the gear. At this point, the head of the motor should be parallel with the Boat Keel, and the top of the foot pedal should be parallel with the Boat Deck.

NOTICE: The top of the Wrap Drum has rounded and smooth edges. The bottom of the Wrap Drum is flat, and the teeth that engage the Cable Spline Gear are visible in the center.

CAUTION

If the Wrap Drum becomes unintentionally disengaged from the Cable Gear, the Steering Cables can become unwound and needs to be reassembled correctly for proper operation.

NOTICE: When seating the Wrap Drum, make sure not to pinch the motor power or steering sensor wires between the Wrap Drum and the Cable Spline Gear.

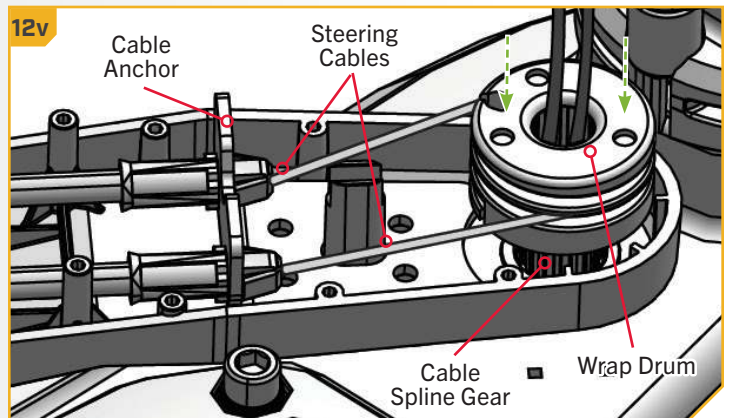
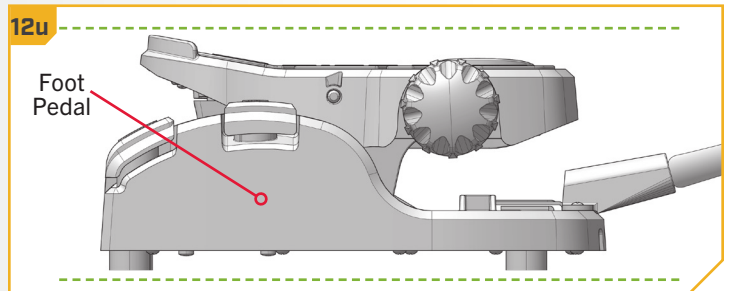
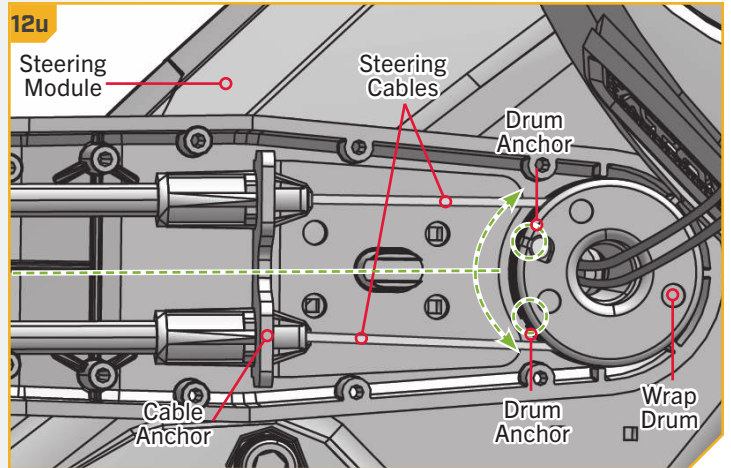

NOTICE: When adjusting the Wrap Drum, the Cable Anchor and the bottom of the Pedal Control Sleeve Assembly will be loose. The pieces are loose to help facilitate the rotation and the tension on the cables for the adjustment.

ROTATE THE PEDAL CONTROL SLEEVE ASSEMBLY FOR A STARBOARD MOUNT

13

- w. Take the three Cable Anchor Screws that hold the Cable Anchor to the Steering Module and replace them using a #2 Phillips Screwdriver. The screws should pass through the Cable Anchor and the bottom of the Pedal Control Sleeve Assembly and into the Steering Module. Tighten the Cable Anchor Screws to 30 in-lbs.

NOTICE: The Cable Anchor and the Pedal Control Sleeve Assembly contain four holes to secure the assembly to the Steering Module, but only three holes are used. Ensure the screws are placed in the correct holes to replace the Pedal Control Sleeve Assembly and Cable Anchor. The hole that should not be used will not have a threaded hole into the Steering Module to secure the Cable Anchor Screw. For trolling motors mounted on the Starboard side of the Boat Deck, this hole will be the furthest inboard toward the Keel and align inboard from the Steering Module.

- x. Once the screws are in place, return to the Foot Pedal.

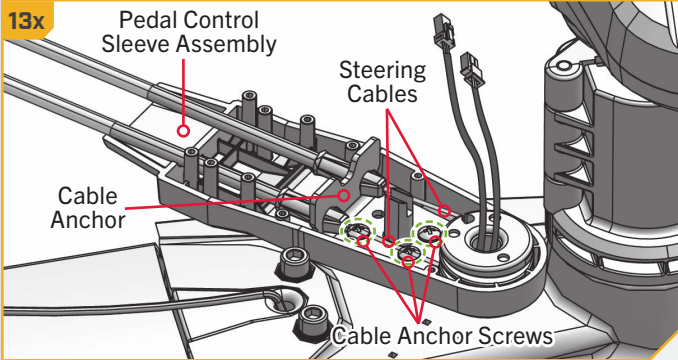
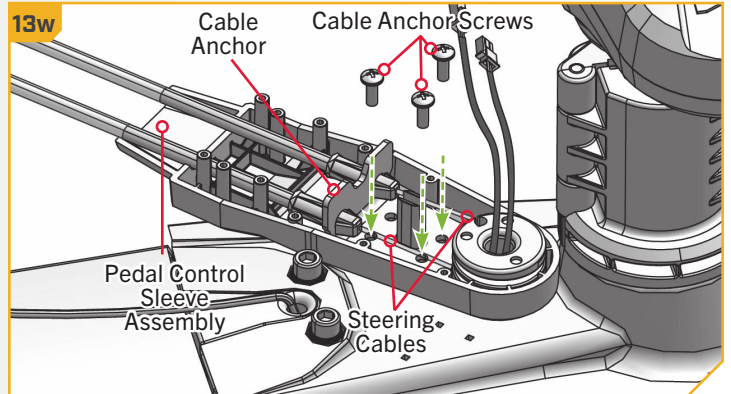
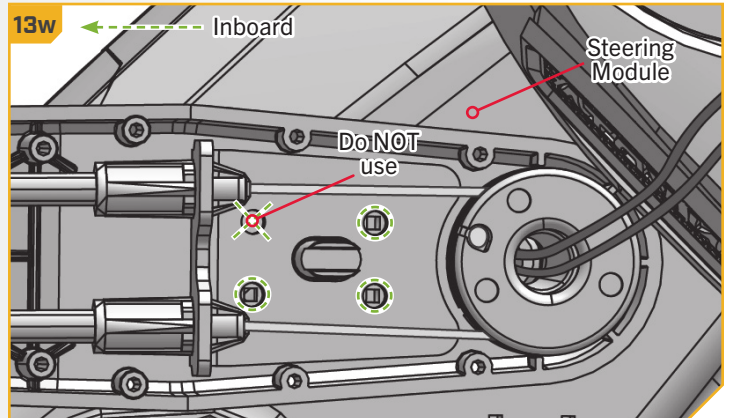

14

- y. Using a #3 Phillips Screwdriver, tighten the Cable Tension Screw located at the base of the Toe End of the Foot Pedal to 10 - 12 in-lbs until the Steering Cables are under tension, or re-tighten the Cable Tension Screw the same number of turns it was loosened to at the beginning of the process.

CAUTION

Do not over-tighten the Cable Tension Screw, as excessive tension will cause damage to the unit.

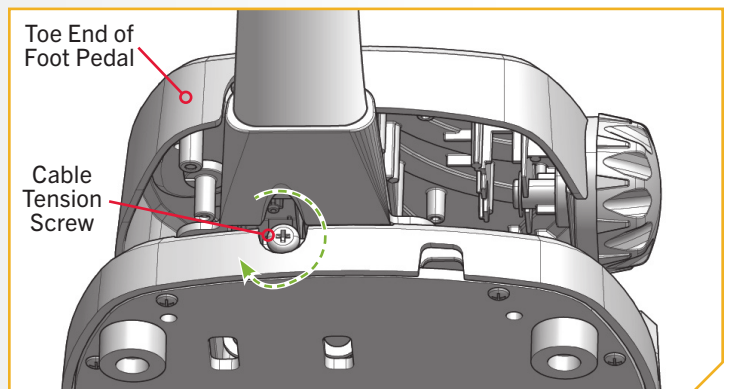

ROTATE THE PEDAL CONTROL SLEEVE ASSEMBLY FOR A STARBOARD MOUNT

15

z. The wires from the Steering Module go through the center of the Cable Spline Gear and the Wrap Drum. The mated connection to these wires enters the Pedal Control Sleeve Assembly from the Coil Cord. Match the wire with the white Clip with the corresponding wire with the white Clip and press the connection together.

aa. Do the same for the wires with the black Clip.

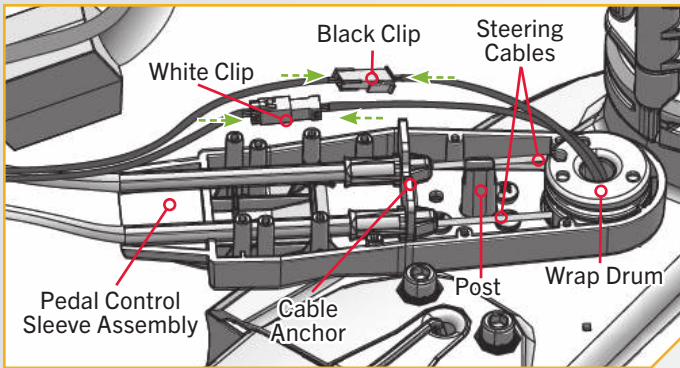
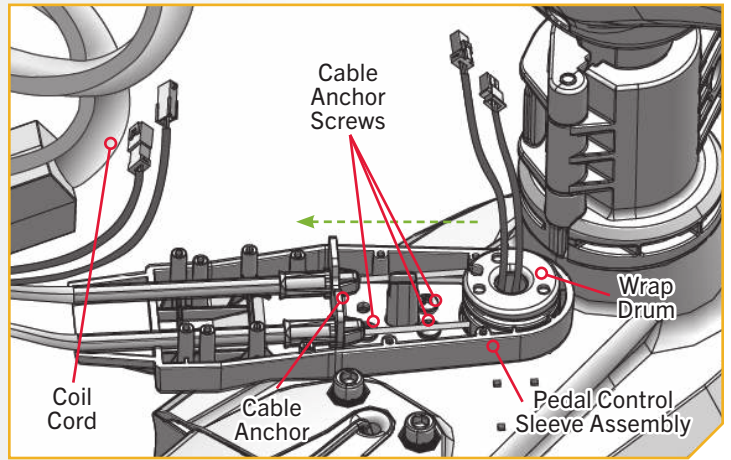

16

ab. With the Clips secured, guide the wires from the Wrap Drum straight and position them towards the Coil Cord away from the Wrap Drum.

ac. To cleanly place the wires inside the Pedal Control Sleeve Assembly, start with the wire with the white Clip. Place the wire with the white Clip in the groove of the Post on the Cable Anchor. Then gently guide the wire past the "V" groove of the Cable Anchor.

ad. Take the white Clips and gently bend the wires so that the slack in the wires forms a loose "S" shape. Guide it to the side of the Cable Anchor where the Steering Cables are coated with a black sleeve away from the Wrap Drum. Place the white Clip and the "S" shaped wire between the black sleeve on the Cables.

ae. Repeat the process for the wire with the black Clip. Shape the wire with the black Clip into a small loop rather than an "S" shape.

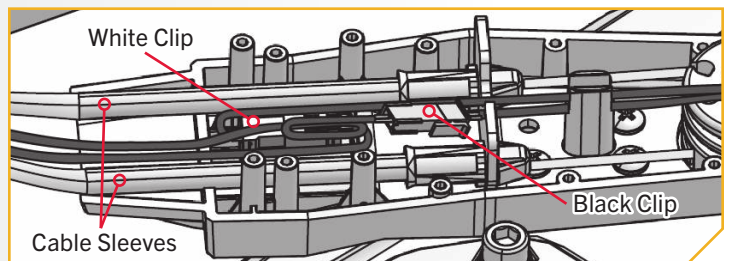
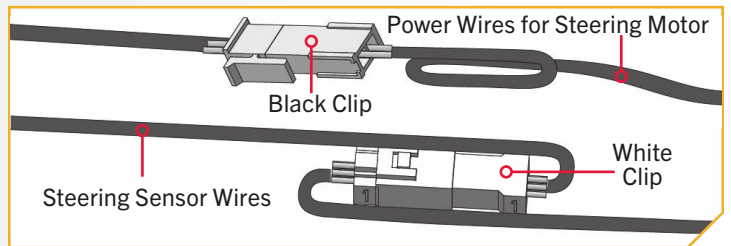
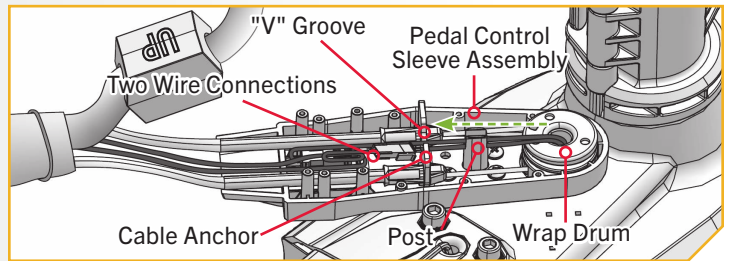

NOTICE: Ensure the wires remain in the Post when complete.

ROTATE THE PEDAL CONTROL SLEEVE ASSEMBLY FOR A STARBOARD MOUNT

17

- af. Ensure the wires are seated and will not be pinched or kinked when the Pedal Control Sleeve Assembly Cover is replaced.
- ag. Take the Pedal Control Sleeve Assembly Cover and rotate it so that the rounded end is over the Wrap Drum. Place the cover on the Pedal Control Sleeve Assembly.
- ah. Take the screws and place one in each of the eight Mounting Holes with recessed embossing. Use a #2 Phillips Screwdriver and tighten to 13 in-lbs.

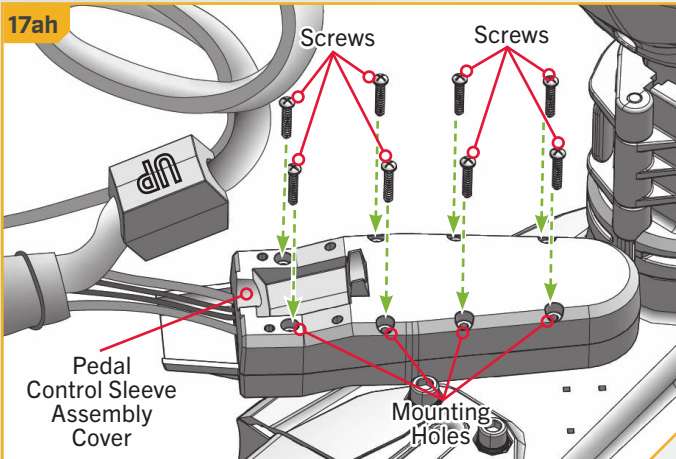
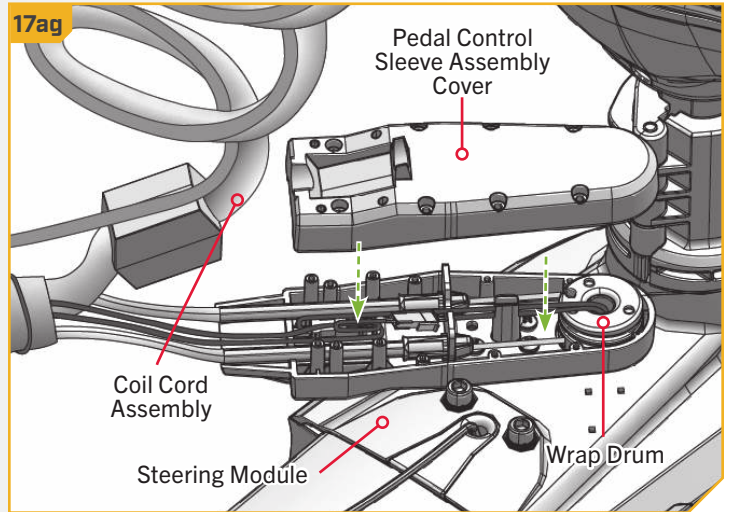

18

- ai. The Coil Cord Assembly is covered by a Sleeve that joins the wires and cables that exit the Pedal Control Sleeve Assembly and extends to the Foot Pedal. The Sleeve is secured with a Cable Tie, which joins with the Coil Cord.
- aj. Adjust the Coil Cord so that the Sleeve with the Cable Tie sits into the bottom recess of the Pedal Control Sleeve Assembly. To do this, rotate the main part of the Coil Cord Assembly by the Molded Block. The Molded Block is rectangular in shape and should be rotated so that the word "UP" molded into the block is facing upward. Press the Molded Knob into the Pedal Control Sleeve Assembly Cover until seated.

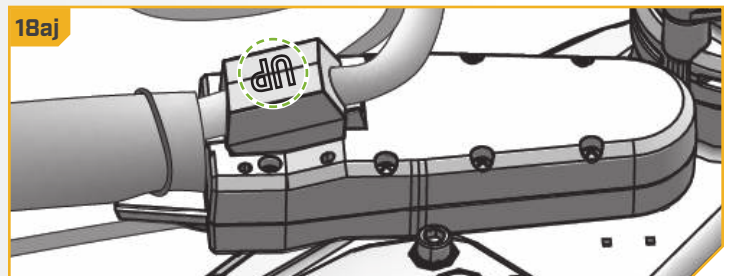
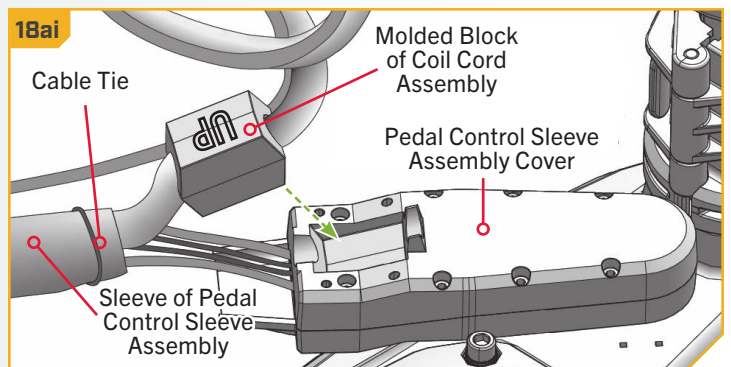

ROTATE THE PEDAL CONTROL SLEEVE ASSEMBLY FOR A STARBOARD MOUNT

19

ak. The Molded Block of the Coil Cord Assembly should be seated, and the Cable Tie and Sleeve should be secured in the recess at the bottom of the Pedal Control Sleeve Assembly. Take the Coil Cord Cover and replace it on the Pedal Control Sleeve Assembly and Molded Block. The stepped design of the Cover fits around the back of the Pedal Control Sleeve Assembly. Be sure that the Coil Cord exits the assembly and that the Sleeve and Cable tie below it are in place. The wires and Sleeve should be captured but not pinched between the Cover and Sleeve.

NOTICE: If present, do not capture the Sonar or Ethernet Cables in the Coil Cord Cover. Re-capture these cables that run along the side of the Coil Cord Cover during the re-installation of the Clips.

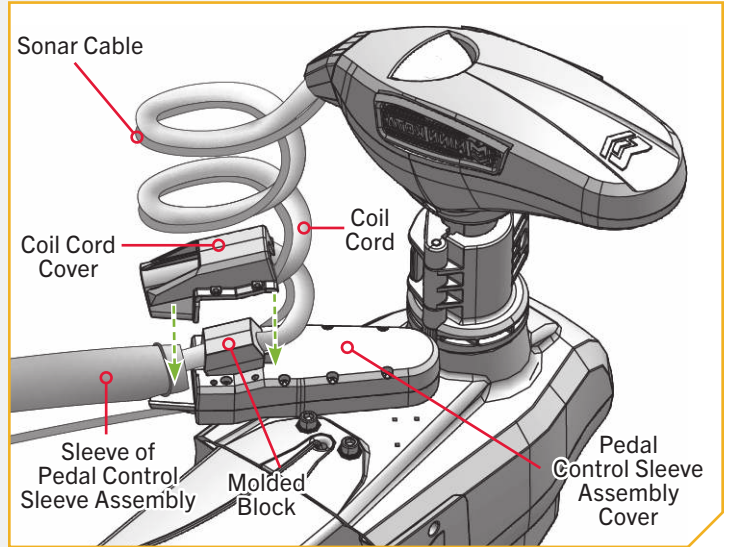

20

al. Take the four screws and two Clips that were removed at the beginning of the installation and replace them. The Clips should be installed with the two screws on the starboard side of the motor for a standard installation. When installing the Clips, they should be rotated so that the opening is downward toward the Boat Deck. Replace the two screws that hold the Clips first so that they first go through the Coil Cord Cover and into the Pedal Control Sleeve Assembly. Use a #2 Phillips Screwdriver. If present, capture the Sonar or Ethernet Cables into the Clips when they are reinstalled.

NOTICE: Only some installations will be standard. Consider installing the Clips on the Port or Starboard side based on the best configuration for the installation. The placement of the Clips is to route cables away from the Steering Module and Mount, where they may cause an obstruction. Ensure the Sonar and Ethernet Cables are captured in the Clips when installed on either side.

am. The screws that do not hold Clips on the Starboard-side of the Mount can be installed directly into the Coil Cord Cover and Pedal Control Sleeve Assembly. Tighten all four screws to 13 in-lbs.

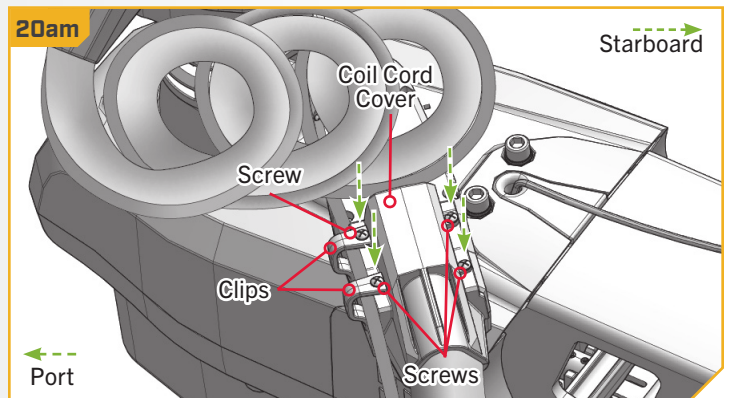
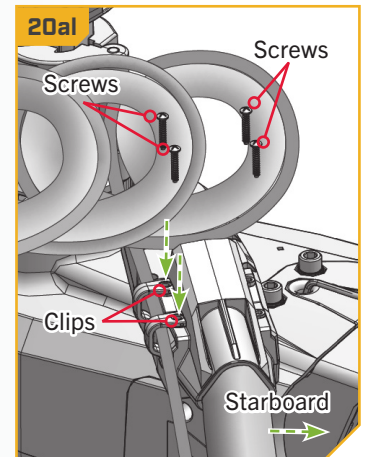
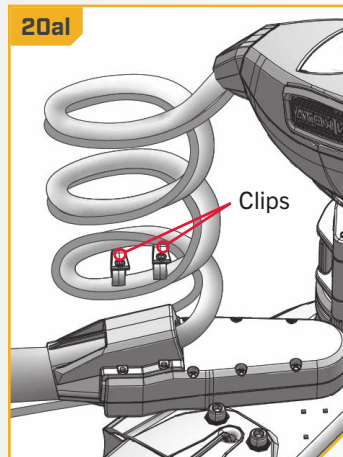

PLACING THE BOW-MOUNT STABILIZER

Placing the Bow-Mount Stabilizer

The Bow-Mount Stabilizer Bracket stabilizes the Steering Module and reduces bouncing when the Motor is stowed and transported. Attention to detail is needed for the successful installation of the stabilizer. Minn Kota recommends having the stabilizer bracket installed by a qualified marine installer.

CAUTION

Adjusting the Aluminum Rod too tightly removes the end play needed for proper latch pin engagement in the Mount, and doing so could prevent the Mount from fully latching in the stowed position. Improper latching may cause damage. If installed correctly, the tip of the Aluminum Rod should lift off of the boat deck about 1/4" without the Mount unlatching. Cutting the Aluminum Rod too short will cause inadequate support for the Mount. Lack of Mount support may cause damage. Failure to install the Bow-Mount Stabilizer may result in damage to your motor and may adversely affect your warranty.

1

ITEM(S) NEEDED

 #30 x 1  #28 x 1  #24 x 1  #26 x 1  #22 x 1  #32 x 2

- Place the Motor in the stowed position.
- Remove the Top Bumper (Item #30) and the Bottom Bumper (Item #22) from the Aluminum Rod (Item #24) and set the bumpers aside. Unscrew the Stabilizer Bracket (Item #28) from the Aluminum Rod. Keep the Jam Nut (Item #26) on the Aluminum Rod. Set the Aluminum Rod with Jam Nut aside.

NOTICE: The Bottom Bumper is made of a rubber material. When reinstalling, ensure both bumpers are reinstalled in the correct position.

NOTICE: Install the Bow-Mount Stabilizer Bracket on the Port or Starboard side of the Steering Module. When mounting the Stabilizer Bracket onto the Ultrex QUEST, discard the two Nylock Nuts (Item #32). Only the bolts and Lock Washers are used for the Stabilizer Bracket when installed directly into the Steering Module.

- Determine the desired location for mounting the Stabilizer Bracket to the Steering Module, either Port or Starboard. Position the Stabilizer Bracket in line with the mounting holes on the bottom of the Steering Module.

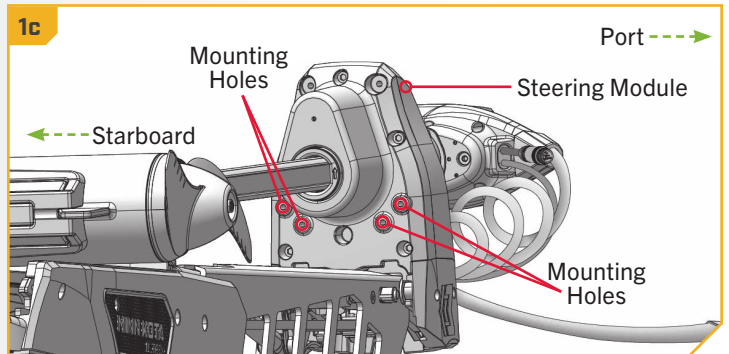
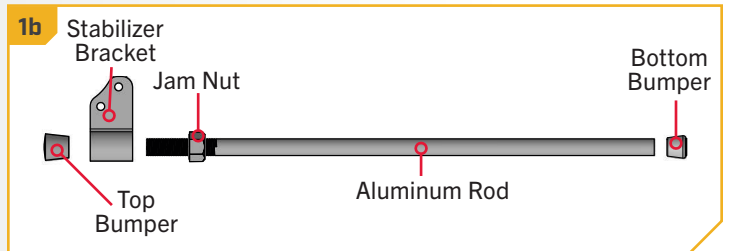

PLACING THE BOW-MOUNT STABILIZER

2

ITEM(S) NEEDED

 #34 x 2  #36 x 2

- d. Take two 5/16" Cap Screws (Item #34) and place one Lock Washer (Item #36) on each screw. Use the screws with the Lock Washers to secure the Stabilizer Bracket to the Steering Module. Tighten with a 1/4" Allen Wrench to 10 ft-lbs.

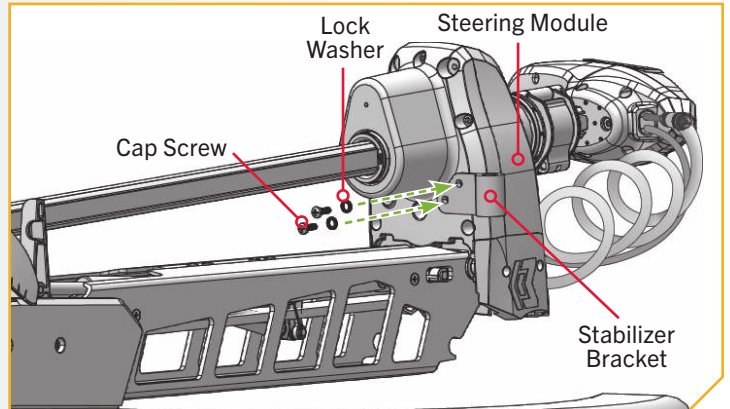

3

- e. Take the Aluminum Rod with Jam Nut in place.
- f. Stand the Aluminum Rod with the threaded end down. Set it on the Boat Deck so it sits vertically next to the Stabilizer Bracket. Use this position to measure the Aluminum Rod to cut it to the proper length.

 **CAUTION**

Cutting the Aluminum Rod too short will cause inadequate support for the Mount. Lack of Mount support may cause damage.

- g. Mark the Aluminum Rod with a pencil or marker 3/4" past the top of the Stabilizer Bracket.
- h. Cut the Aluminum Rod with a Hack Saw at the mark. Round the cut edge of the rod with a file or sandpaper to remove any sharp edges.

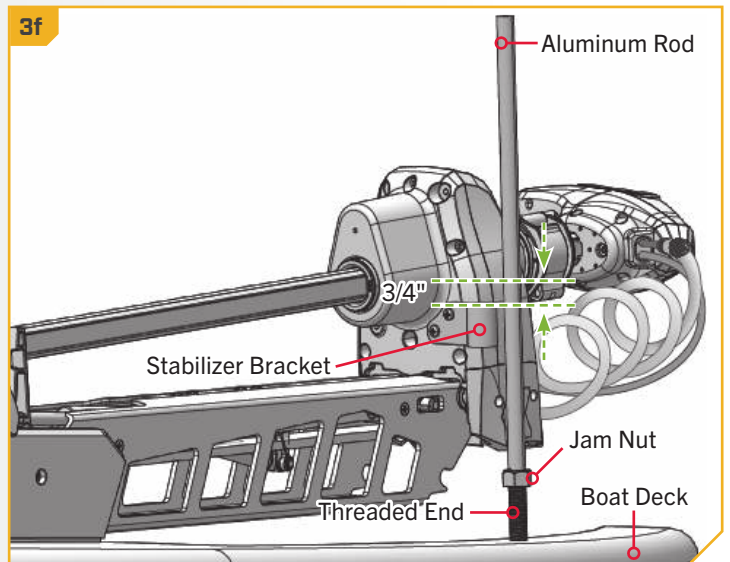
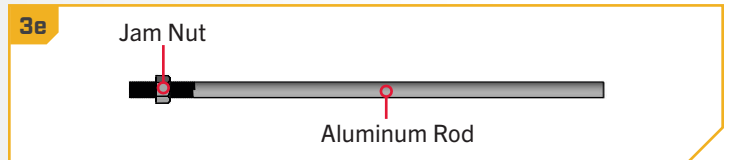

PLACING THE BOW-MOUNT STABILIZER

4

- i. Replace the Bottom Bumper on the Aluminum Rod, opposite from the threads, over the cut end.
- j. Thread the Aluminum Rod into the Stabilizer Bracket with the Bottom Bumper towards the Boat Deck.
- k. Adjust the Aluminum Rod up or down in the Stabilizer Bracket. The Bottom Bumper should rest on the Boat Deck.

CAUTION

Adjusting the Aluminum Rod too tightly removes the end play needed for proper latch pin engagement in the Mount, and doing so could prevent the Mount from fully latching in the stowed position. Improper latching may cause damage. If installed correctly, the Aluminum Rod tip should lift off the Boat Deck about 1/4" without the Mount unlatching.

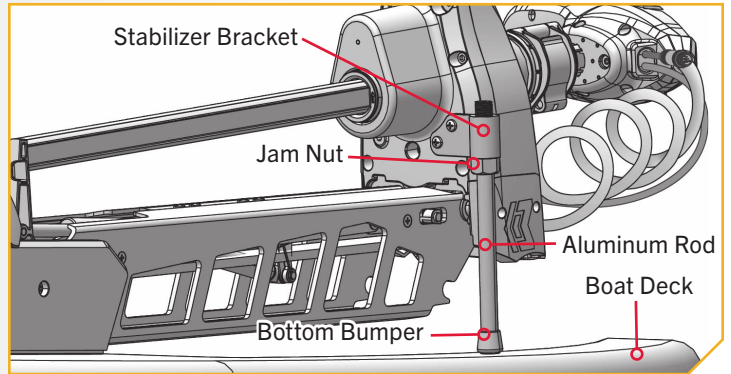

NOTICE: When placing the Aluminum Rod for final installation, the threaded end faces upward.

5

- l. Once in the correct position, tighten the Jam Nut upwards against the Stabilizer Bracket by turning it clockwise. A tight Jam Nut will prevent the Aluminum Rod from turning.
- m. Install the Top Bumper on any exposed threads on the Aluminum Rod above the Stabilizer Bracket.

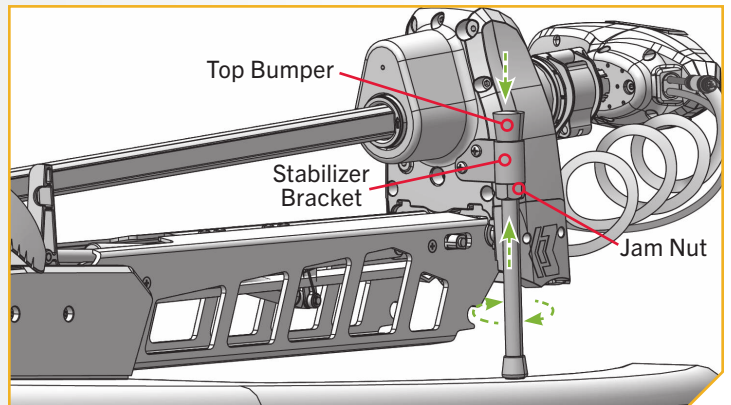

IDENTIFYING TROLLING MOTOR FEATURES AND THEIR ASSOCIATED CABLES

IDENTIFYING TROLLING MOTOR FEATURES AND THEIR ASSOCIATED CABLES

Feature & Cable Identification

The Ultrex QUEST is pre-installed with Advanced GPS Navigation - including the ability to connect via Ethernet to a Humminbird unit. It may also be installed with sonar, either Dual Spectrum CHIRP or Built-in MEGA Side Imaging. Dual Spectrum CHIRP and Built-in MEGA Side Imaging will be installed in combination with Advanced GPS Navigation. All of these features require Accessory Cables to be connected to an output device. The connectors are present on the trolling motor and have cables that exit below the Control Head or run parallel to the Coil Cord and exit at the base of the Mount. To better identify Accessory Cables present, refer to the diagrams that detail what the Dual Spectrum CHIRP, Built-in MEGA Side Imaging and Advanced GPS Navigation connectors look like.

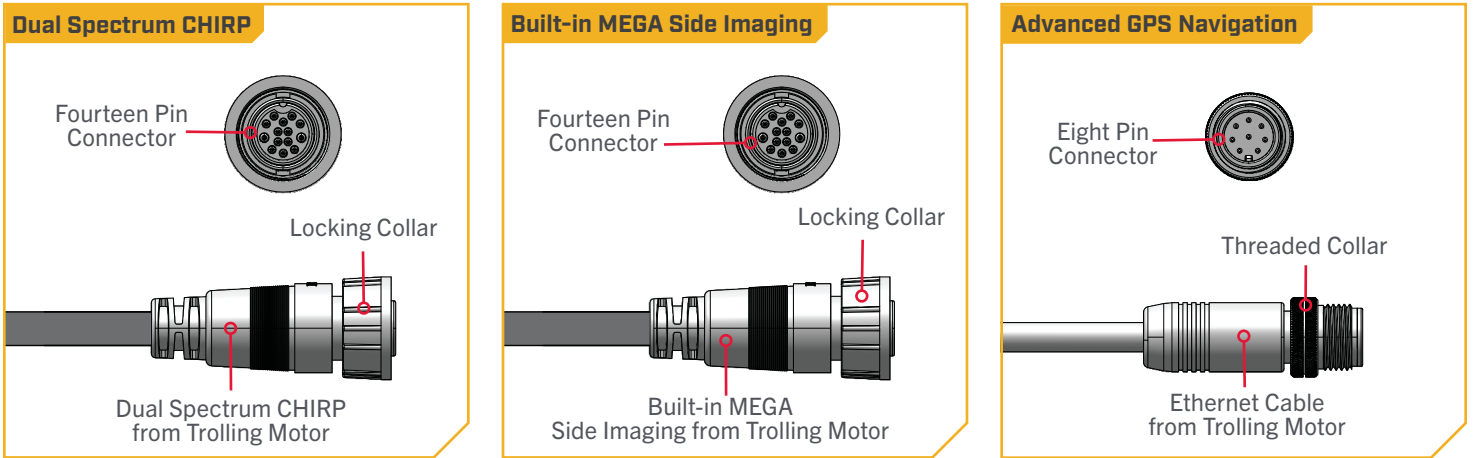

IDENTIFYING TROLLING MOTOR FEATURES AND THEIR ASSOCIATED CABLES

Identifying Connectors

Every Ultrex QUEST will have **TWO** connectors present below the Control Head. The trolling motor will be equipped with:

Advanced GPS Navigation & Dual Spectrum CHIRP or Built-in MEGA Side Imaging - Advanced GPS Navigation is pre-installed on your trolling motor. One Eight Pin Advanced GPS Ethernet Connector will exit the base of the Control Head and rest just below the Control Head next to the Coil Cord. If the Advanced GPS Navigation on the trolling motor will be used with a fish finder, an Ethernet Cable may be attached to the Advanced GPS Ethernet Connector below the Control Head. See the “Advanced GPS Navigation” section of this document for details on how to install the Advanced GPS Ethernet Connector to a Humminbird.

Dual Spectrum CHIRP or Built-in MEGA Side Imaging is pre-installed on your trolling motor. One Sonar Accessory Cable will exit the base of the Control Head and run parallel to the Coil Cord. The Cable will come installed from the factory secured to the Coil Cord. The end of the Cable will have a Fourteen Pin Connector. Motors with Dual Spectrum CHIRP or Built-in MEGA Side Imaging will also have a transducer in the Lower Unit. The appearance of the transducer will vary depending on sonar type.

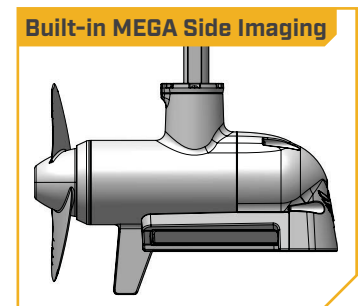
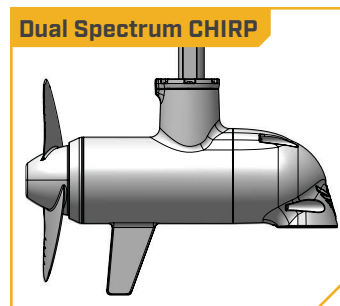
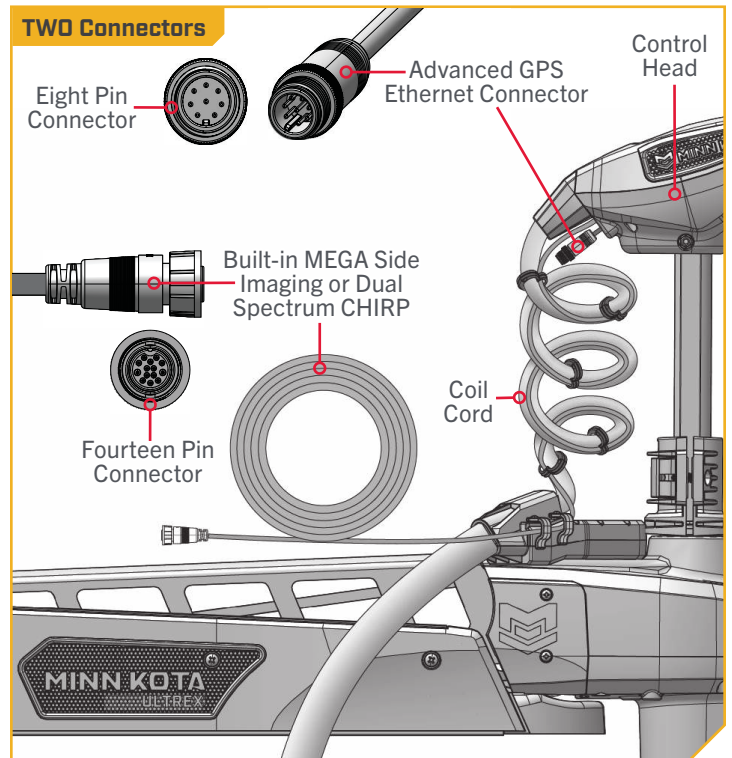

DUAL SPECTRUM CHIRP

› Feature & Cable Management

DUAL SPECTRUM CHIRP ›

Your trolling motor may be pre-installed with a transducer system featuring Humminbird's Dual Spectrum CHIRP. CHIRP stands for "Compressed High Intensity Radar Pulse". Dual Spectrum CHIRP is a 2D sonar transducer with a temperature sensor that is integrated into the lower unit of the trolling motor. Humminbird also utilizes a proprietary, best-in-class transducer designed and built to maximize fish detail, as well as coverage area. Dual Spectrum CHIRP scans the water for fish similar to the way the seek function on your truck's radio scans the airwaves for FM stations. By covering a wide range of frequencies, CHIRP produces more accurate, more detailed returns of fish, structure, and the bottom.

Humminbird's Dual Spectrum CHIRP gives you full spectrum capability, plus the power to select your own start and end frequencies by operating in two different modes. Wide Mode for maximum coverage and Narrow Mode for maximum detail. Wide mode allows you to search deep and wide. Is it used for watching your lure while vertical jigging, or gaining a more expansive view in shallow water. Narrow Mode is used to hone in on the small stuff that makes a big difference. Narrow Mode provides a precise perspective of the water below, helping you target individual fish, or identify fish hidden in structure and/or tight to the bottom.

Dual Spectrum CHIRP features:

SUPERIOR TARGET SEPARATION - Separating fish from their habitat is the name of the game. And now, you'll be able to tell the difference more easily between bait and game fish, and nearby structure and vegetation.

CLEARLY DEFINED FISH ARCHES - We've got bad news for your arch nemesis. Large game fish will show up on your screen as long, well-defined arches, for quick identification and accurate lure presentation.

STRONG RETURNS WITHOUT NOISE - Stop seeing things that aren't there. A high signal-to-noise ratio translates to better defined targets, less clutter and greater certainty that what you're looking at on-screen is legit.

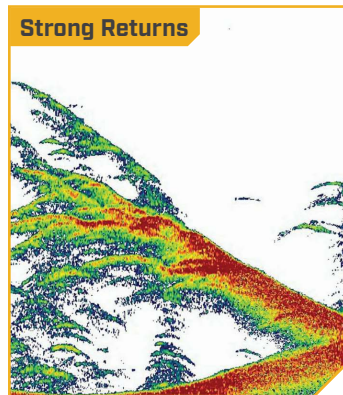
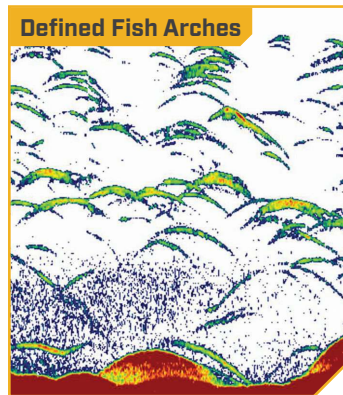
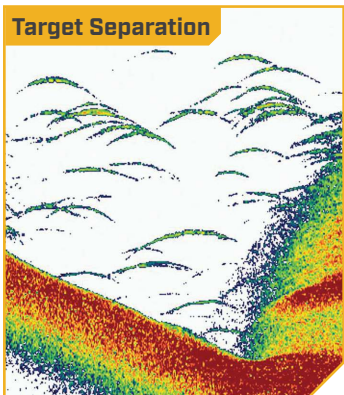
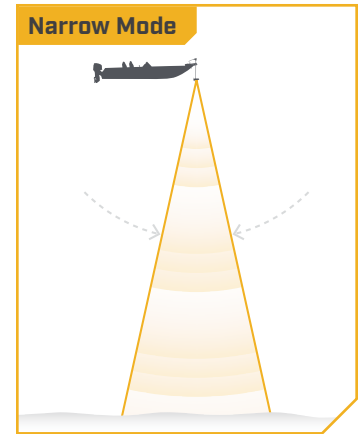
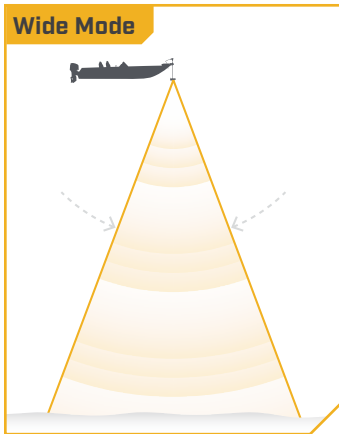
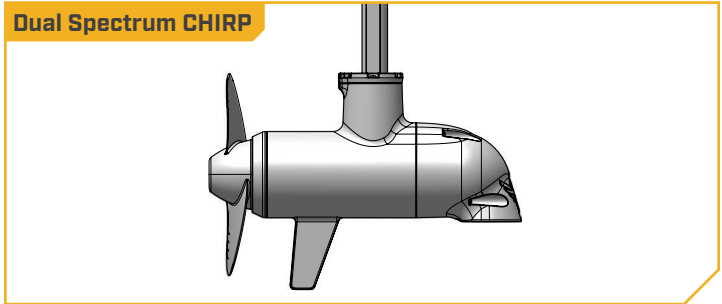

The integrated design of the Dual Spectrum CHIRP transducer protects it in the lower unit of the trolling motor from underwater hazards and prevents tangles and damage to the transducer cables. In certain situations, air bubbles may adhere to the surface of the Dual Spectrum CHIRP transducer and affect the performance. If this happens, simply wipe the surface of the transducer with your finger.

› Considerations for Connecting and Routing Dual Spectrum CHIRP

If Dual Spectrum CHIRP is pre-installed on your trolling motor, one Dual Spectrum CHIRP accessory cable will exit the base of the Control Head and run parallel to the Coil Cord. The cable will come installed from the factory secured to the Coil Cord. Dual Spectrum CHIRP requires cables to be connected to an output device such as a Humminbird® fish finder. The Dual Spectrum CHIRP cable that is secured to the Coil Cord is "Apex and Solix Ready". Connecting the trolling motor equipped with a Dual Spectrum CHIRP transducer to a compatible fish finder gives you a 2D sonar view of what is happening directly below your trolling motor. To determine if your fish finder is compatible with Dual Spectrum CHIRP, please visit minnkota.johnsonoutdoors.com to check compatibility. The Dual Spectrum CHIRP cable from the trolling motor may be plugged directly into a Solix or Apex, directly into an Extension Cable or directly into a Humminbird® Helix Adapter Cable.

EXTENSION CABLES - The Dual Spectrum CHIRP cable from the trolling motor may not be long enough to reach your fish finder. If the cable length does not reach the desired fish finder installation location, extension cables are available. A 10-foot extension cable ([EC M3 14W10 - 10' transducer extension cable - 720106-1](#)) and a 30-foot extension cable ([EC M3 14W30 - 30' transducer extension cable - 720106-2](#)) are available from humminbird.johnsonoutdoors.com. Both the 10-foot and 30-foot extension cables also come "Apex and Solix Ready". The Extension Cables may plug directly into a Solix or Apex or directly into a Helix Adapter Cable.

HUMMINBIRD HELIX ADAPTER CABLES - If connecting to a Humminbird® Helix fish finder, an adapter cable accessory is included that will allow the connection of any compatible Humminbird® Helix fish finder.

OTHER FISH FINDER ADAPTER CABLES - If connecting to other fish finders on the market, check for compatibility or any required adapter cables online at minnkota.johnsonoutdoors.com.

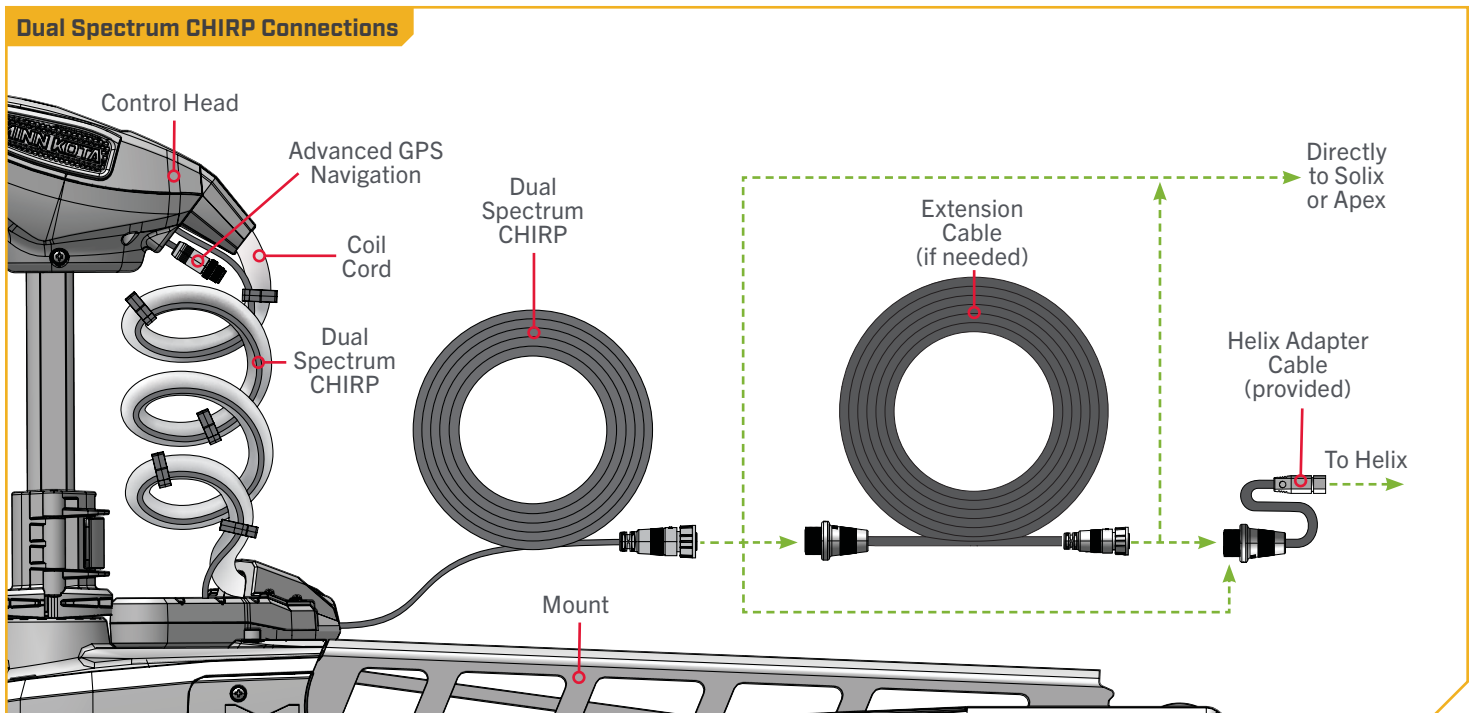

DUAL SPECTRUM CHIRP

Incorrect rigging will cause sonar interference and can damage your trolling motor, electronics, and other boat accessories. To minimize trolling motor interference, ensure that the fish finder and trolling motor are powered by separate batteries. Please refer to the "Battery & Wiring Installation" and "Motor Wiring Diagram" sections of this manual for correct rigging instructions.

The Dual Spectrum CHIRP cables are shielded to minimize interference. To protect this shielding, the cables should not be pulled tight against sharp angles or hard objects. If using cable ties, do not over-tighten. Any excess cable should be bundled in a loose loop of no less than 4" in diameter. The connection cable should be routed to the fish finder following Minn Kota recommendations on routing the cables to optimize mobility and maximize functionality. Follow the instructions below for completing all connections and then follow the instructions for "Securing Connection Cables" to complete the output cable installation.

CAUTION

Failure to follow the recommended wire routing for installed features, if equipped, may cause damage to the product and void your product warranty. Route cables away from pinch points or other areas that may cause them to bend in sharp angles. Routing the cables in any way other than directed may cause damage to the cables by being pinched or severed. Do not over-tighten cable ties or clips as it may damage the wires.

1

NOTICE: Your fish finder should be turned off until this procedure is complete.

- a. Place the motor in the deployed position.
- b. Locate the Fourteen Pin Connector on the end of the Dual Spectrum CHIRP accessory cable. The cable will come installed from the factory secured to the Coil Cord with Clips.
- c. Determine if the Plug on the end of the Dual Spectrum CHIRP accessory cable will be attached directly to:
 - 1) a Humminbird® Solix or Apex fish finder,
 - 2) a Dual Spectrum CHIRP Extension Cable,
 - 3) a Helix Adapter Cable or a compatible fish finder adapter cable.

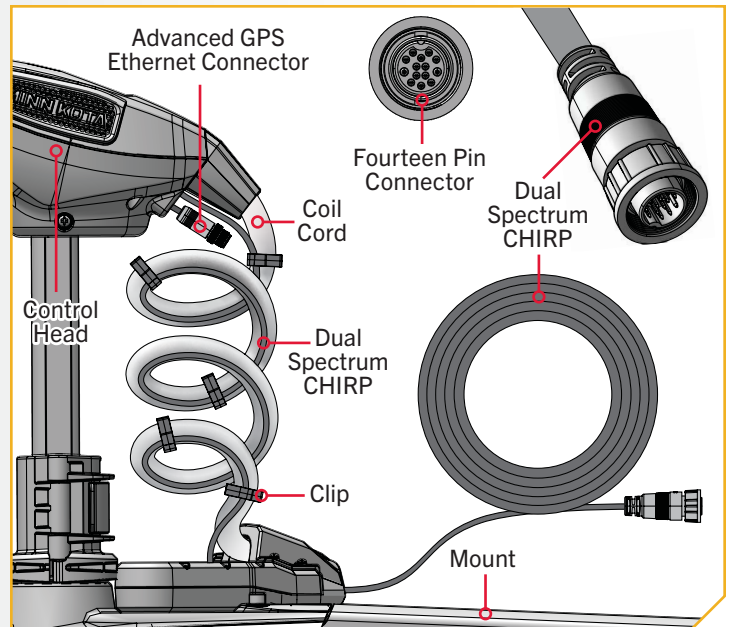

2

- d. If installing directly to a Solix or Apex, the connection will be flat on the back of the fish finder display.
- e. Align the pins on the Accessory Cable with the receptacle on the fish finder. Notice the keyed connectors. Tighten the Collar from the accessory cable to secure the connection. Once directly installed to the Solix or Apex, the connection is complete.

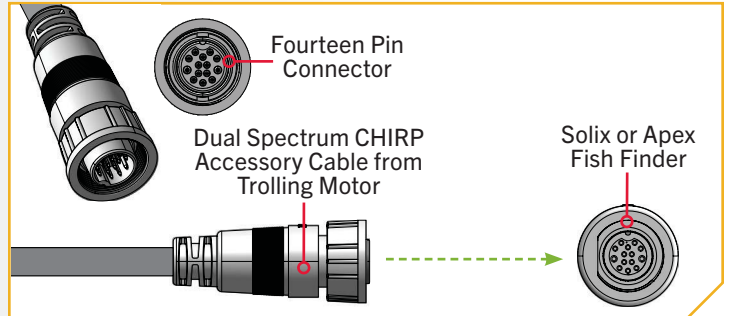

3

- f. If installing directly to a Dual Spectrum CHIRP Extension Cable, align the pins on the accessory cable with the receptacle on the extension cable. Notice the keyed connectors. Tighten the Collar from the accessory cable to secure the connection.
- g. If the Dual Spectrum CHIRP extension cable will be attached directly to a Humminbird® Solix or Apex, the connection will look exactly like the installation directly into a Humminbird Solix or Apex fish finder.

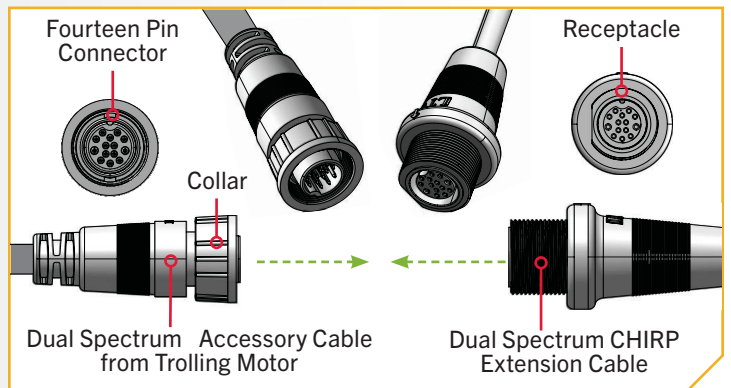

NOTICE: A 10-foot extension cable (EC M3 14W10 - 10' transducer extension cable - 720106-1) and a 30-foot extension cable (EC M3 14W30 - 30' transducer extension cable - 720106-2) are available from humminbird.johnsonoutdoors.com.

DUAL SPECTRUM CHIRP

4

ITEM(S) REQUIRED



- h. If installing directly to a Helix Adapter Cable, align the pins on the accessory cable or extension cable with the receptacle on the Helix Adapter Cable (Item #46 or 48). Notice the keyed connectors. Tighten the Collar from the accessory cable or extension cable to secure the connection.
- i. If the Helix Adapter Cable will be attached directly to a Humminbird® Helix, plug it in the Helix Adapter Cable Keyed Connection on the back of the fish finder.

NOTICE: If connecting to other fish finders on the market, check for compatibility or any required adapter cables online at minnkota.johnsonoutdoors.com.

- j. If your trolling motor has more than one external connector for an output device, complete the connection for that specific output and then follow the instructions for "Securing Accessory Cables" to complete the output cable installation.

NOTICE: If unsure of what features your trolling motor may be installed with that require connection to an output device, please review the "Identifying Trolling Motor Features And Their Associated Cables" section in this document.

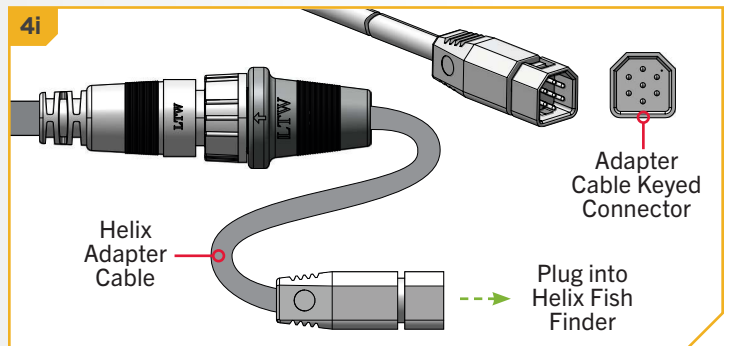
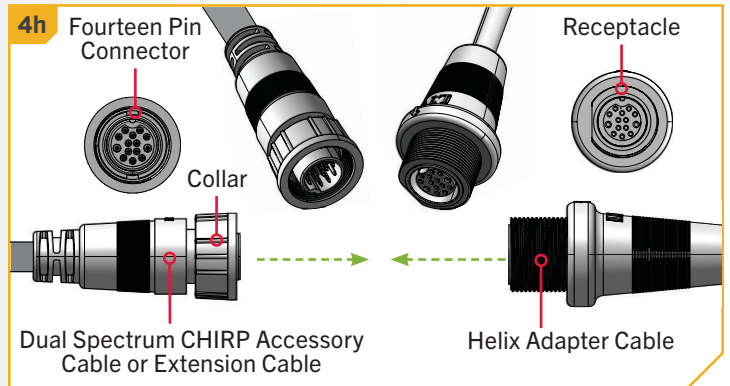

BUILT-IN MEGA SIDE IMAGING >

With Built-in MEGA Side Imaging it's all in the details. Gain a 180 degrees side-to-side perspective on the world below the surface with remarkable Humminbird® Side Imaging®. In an instant, the ultra-thin beam scans the area up to 400 feet to the left and right of your boat location - for total coverage of up to 800 feet. The return image for each slice is then added to the images taken immediately before and after to build an incredible view of the lake bottom. You can then magnify the detail of the image with the zoom feature or mark the GPS location of promising cover or structure directly on the screen. The Built-In MEGA DI transducer is only available on new models equipped from the factory and cannot be added to an existing trolling motor.

> Considerations for Connecting and Routing Built-in MEGA Side Imaging

If Built-in MEGA Side Imaging is pre-installed on your trolling motor, one Built-in MEGA Side Imaging accessory cable will exit the base of the Control Head and run parallel to the Coil Cord. The cable will come installed from the factory secured to the Coil Cord. Built-in MEGA Side Imaging requires cables to be connected to an output device such as a Humminbird® fish finder. The Built-in MEGA Side Imaging cable that comes from the factory secured to the Coil Cord is "Apex and Solix Ready". Connecting the trolling motor equipped with a Built-in MEGA Side Imaging transducer to a compatible fish finder gives you a 2D sonar view of what is happening directly below your trolling motor. To determine if your fish finder is compatible with Built-in MEGA Side Imaging, please visit minnkota.johnsonoutdoors.com to check compatibility. The Built-in MEGA Side Imaging cable from the trolling motor may be plugged directly into a Solix or Apex, directly into an Extension Cable or directly into a Humminbird® Helix Adapter Cable.

EXTENSION CABLES - The Built-in MEGA Side Imaging cable from the trolling motor may not be long enough to reach your fish finder. If the cable length does not reach the desired fish finder installation location, extension cables are available. A 10-foot extension cable (**EC M3 14W10 - 10' transducer extension cable - 720106-1**) and a 30-foot extension cable (**EC M3 14W30 - 30' transducer extension cable - 720106-2**) are available from humminbird.johnsonoutdoors.com. Both the 10-foot and 30-foot extension cables also come "Apex and Solix Ready". The Extension Cables may plug directly into a Solix or Apex or directly into a Helix Adapter Cable.

HUMMINBIRD HELIX ADAPTER CABLES - If connecting to a Humminbird® Helix fish finder, an adapter cable accessory is included that will allow the connection of any compatible Humminbird® Helix fish finder. The 490537-2 MKR-MI-1 is used on Helix 8, 9, 10, 12 and 15 G2N models and newer. The Helix adapter cable will plug directly into the Helix fish finder.

OTHER FISH FINDER ADAPTER CABLES - If connecting to other fish finders on the market, check for compatibility or any required adapter cables online at minnkota.johnsonoutdoors.com.

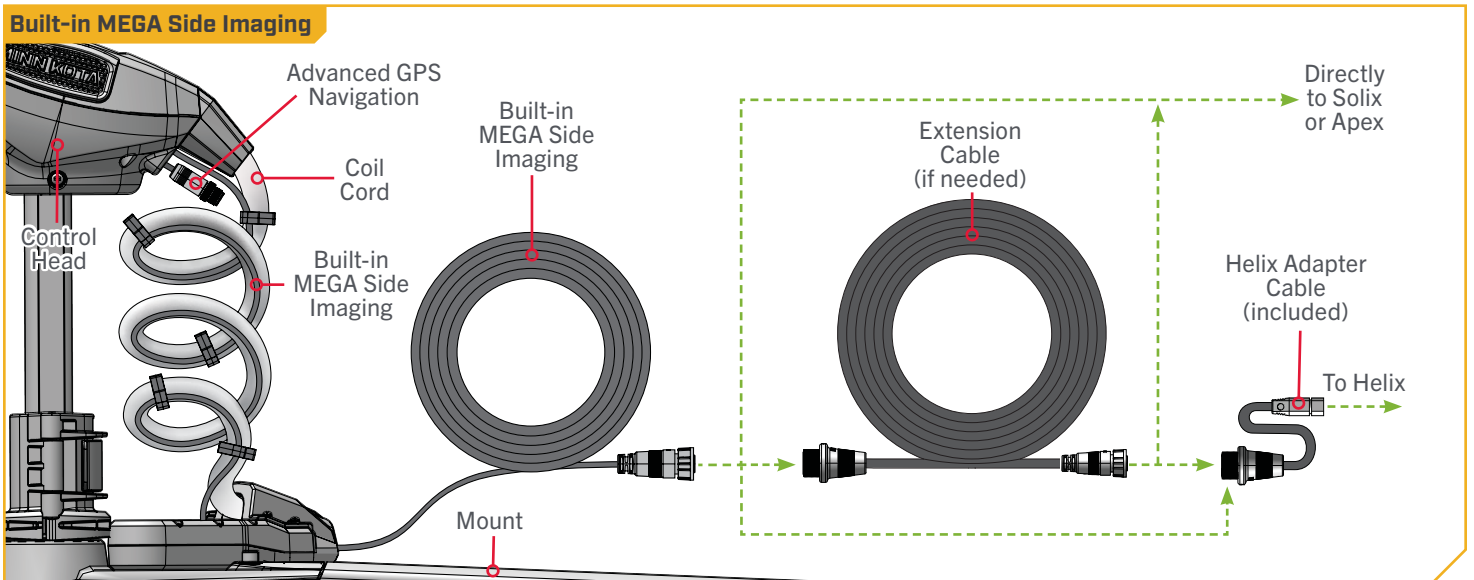

BUILT-IN MEGA SIDE IMAGING

CAUTION

Failure to follow the recommended wire routing for installed features, if equipped, may cause damage to the product and void your product warranty. Route cables away from pinch points or other areas that may cause them to bend in sharp angles. Routing the cables in any way other than directed may cause damage to the cables by being pinched or severed. Do not over-tighten cable ties as it may damage the wires.

NOTICE: You can only view Side Imaging with a MEGA DI or MEGA SI HELIX G2N, G3N or G4N Series model and a required adapter, or with any SOLIX or APEX Series model. The built-in transducer cannot supply MEGA Imaging to Humminbird models that do not already have the capability. If you have a G2/G2N, G3/G3N or G4/G4N HELIX that is not a MEGA SI or MEGA DI model, you will still get 2D Dual Spectrum CHIRP Sonar from the transducer. SOLIX G1 and HELIX G2 and G2N units need to be running the latest software update to view sonar from motors with Built-In MEGA Imaging. You can get the latest version of software for your fish finder on humminbird.johnsonoutdoors.com. Built-In MEGA Imaging is not supported by HELIX G1 models or other brands of fish finders.

1

NOTICE: Your fish finder should be turned off until this procedure is complete.

- a. Place the motor in the deployed position.
- b. Locate the Fourteen Pin Connector on the end of the Built-in MEGA Side Imaging accessory cable. The cable will come installed from the factory secured to the Coil Cord with Clips.
- c. Determine if the Plug on the end of the Built-in MEGA Side Imaging Cable accessory cable will be attached directly to:
 - 1) a Humminbird® Solix or Apex fish finder,
 - 2) a Built-in MEGA Side Imaging Extension Cable,
 - 3) a Helix Adapter Cable or a compatible fish finder adapter cable.

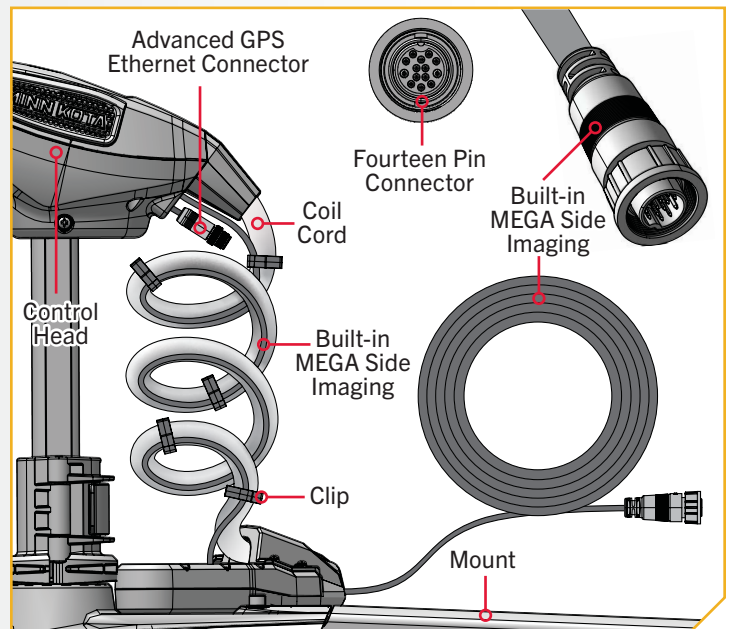

BUILT-IN MEGA SIDE IMAGING

2

- d. If installing directly to a Solix or Apex, the connection will be flat on the back of the fish finder display.
- e. Align the pins on the Accessory Cable with the receptacle on the fish finder. Notice the keyed connections. Tighten the Collar from the accessory cable to secure the connection. Once directly installed to the Solix or Apex, the connection is complete.

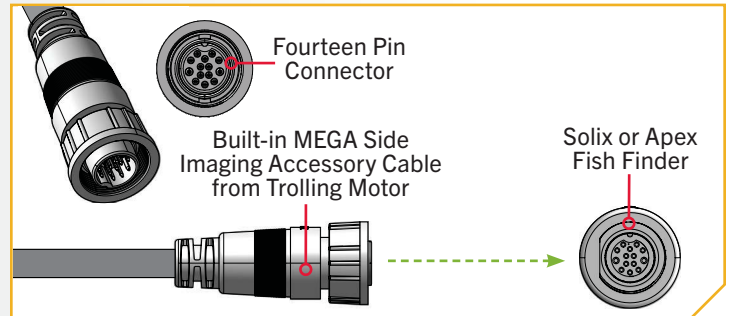

3

- f. If installing directly to a Built-in MEGA Side Imaging Extension Cable, align the pins on the accessory cable with the receptacle on the extension cable. Notice the keyed connectors. Tighten the Collar from the accessory cable to secure the connection.
- g. If the Built-in MEGA Side Imaging Cable extension cable will be attached directly to a Humminbird® Solix or Apex, the connection will look exactly like the installation directly into a Humminbird Solix or Apex fish finder.

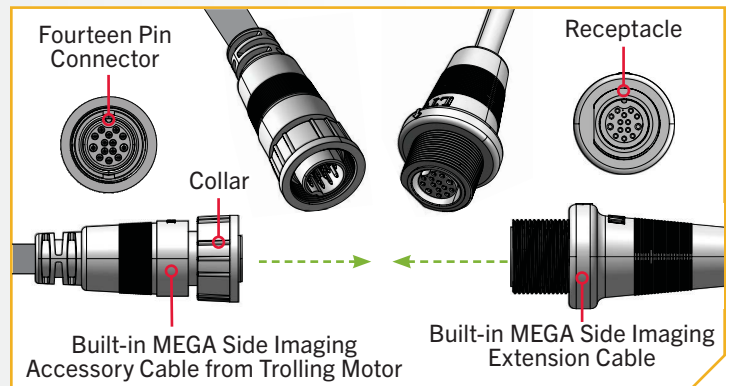

NOTICE: A 10-foot extension cable (EC M3 14W10 - 10' transducer extension cable - 720106-1) and a 30-foot extension cable (EC M3 14W30 - 30' transducer extension cable - 720106-2) are available from humminbird.johnsonoutdoors.com.

BUILT-IN MEGA SIDE IMAGING

4

ITEM(S) NEEDED



- h. If installing directly to a Helix Adapter Cable, align the pins on the accessory cable or extension cable with the receptacle on the Helix Adapter Cable (Item #48). Notice the keyed connectors. Tighten the Collar from the accessory cable or extension cable to secure the connection.

NOTICE: The 490537-2 MKR-MI-1 (Item #48) is a Helix Adapter Cable used on Helix 8, 9, 10, 12 and 15 G2N models and newer.

- i. If the Helix Adapter Cable will be attached directly to a Humminbird® Helix, plug it in the Helix Adapter Cable Keyed Connection on the back of the fish finder.

NOTICE: If connecting to other fish finders on the market, check for compatibility or any required adapter cables online at minnkota.johnsonoutdoors.com.

- j. If your trolling motor has more than one external connector for an output device, complete the connection for that specific output and then follow the instructions for "Securing Accessory Cables" to complete the output cable installation.

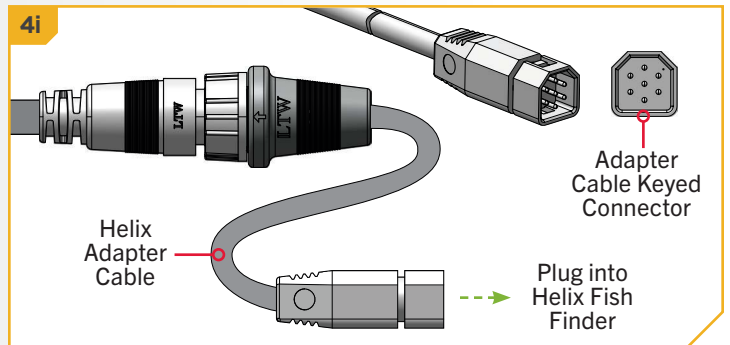
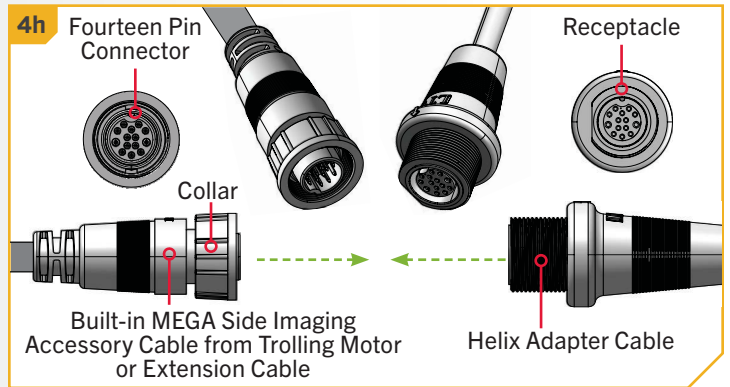

NOTICE: If unsure of what features your trolling motor may be installed with that require connection to an output device, please review the "Identifying Trolling Motor Features and Their Associated Cables" section in this document.

ADVANCED GPS NAVIGATION >

Your Minn Kota trolling motor and Humminbird fish finder communicate with each other to change the way you fish. Advanced GPS Navigation offers a large array of features including controlling speed, steering, Spot-Lock, and the ability to record and retrace tracks on the water, all at your fingertips. To learn more about the GPS capabilities available with your new motor, please refer to the Advanced GPS Navigation Owner's Manual by visiting minnkota.johnsonoutdoors.com.

The remote and GPS controller make up the Advanced GPS Navigation system. A micro remote comes paired to the controller from the factory. The GPS controller contains a very sensitive compass and is where all GPS satellite and remote signals are received. The GPS controller is located in the trolling motor Control Head and may be connected to a fish finder from an Accessory Cable that exits the Control Head. If the Advanced GPS Navigation system will be used with a fish finder, the Ethernet link between the trolling motor and the fish finder must be connected.

> Considerations for Connecting and Routing Advanced GPS Navigation

Advanced GPS Navigation is pre-installed on your trolling motor. One eight pin Advanced GPS Ethernet Connector exits the base of the Control Head and rest just below the Control Head next to the Coil Cord. If the Advanced GPS Navigation on the trolling motor will be used with a fish finder, an Ethernet Cable will need to be attached to the Advanced GPS Ethernet Connector below the Control Head. Consider the distance between the trolling motor and the fish finder to determine how to complete the Ethernet connection.

ETHERNET CABLES - Minn Kota provides one 30 ft Ethernet cable ([AS EC 30E - 30' Ethernet Cable - 720073-4](#)) with every trolling motor equipped with Advanced GPS Navigation. The 30 ft Ethernet cable will accommodate a standard Ethernet connection for most installations to a Humminbird fish finder and is "Apex and Solix Ready". If the distance between the trolling motor and Humminbird fish finder is relatively small and a shorter cable is preferred, alternate cable lengths are available from humminbird.johnsonoutdoors.com. These options include:

- 10 ft - ([AS EC 10E - 10' Ethernet Cable - 720073-2](#))
- 15 ft - ([AS EC 15E - 15' Ethernet Cable - 720073-5](#))
- 20 ft - ([AS EC 20E - 20' Ethernet Cable - 720073-3](#))

Every length of Ethernet cable plugs directly into a Solix or Apex or directly into a Helix Adapter Cable.

HUMMINBIRD HELIX ADAPTER CABLES - Minn Kota provides one Helix Adapter Cable ([AS EC QDE - Ethernet Adapter Cable - 720074-1](#)) with every trolling motor equipped with Advanced GPS Navigation. If the Ethernet connection is being made between the trolling motor and any Humminbird® Helix fish finder, the Helix Adapter Cable should be used. The Helix Adapter Cable directly connects the Ethernet Cable to a Helix fish finder.

ETHERNET EXTENSION CABLES - If the 30 ft Ethernet cable provided with your trolling motor with Advanced GPS Navigation is not long enough to reach the fish finder, an Ethernet Extension cable should be used. The Ethernet Extension cable is available from humminbird.johnsonoutdoors.com and is available in a 30 ft length ([AS ECX 30E - 30' Ethernet Extension Cable - 760025-1](#)). The Ethernet Extension Cable will plug directly into any length of Ethernet cable.

NOTICE: Minn Kota recommends routing the Ethernet Cable or Ethernet Extension Cable parallel with and secured to the Coil Cord when making the Ethernet connection. The cables will be installed from the Mount to the Control Head secured to and parallel with the Coil Cord. Bypassing the Coil Cord when routing the Ethernet Cable or Ethernet Extension Cable is not recommended. Follow the instructions in the "Securing Accessory Cable" section of this document for instructions on how to route the Ethernet Cable through the Clips once connected.

ADVANCED GPS NAVIGATION

GPS Ethernet Connection

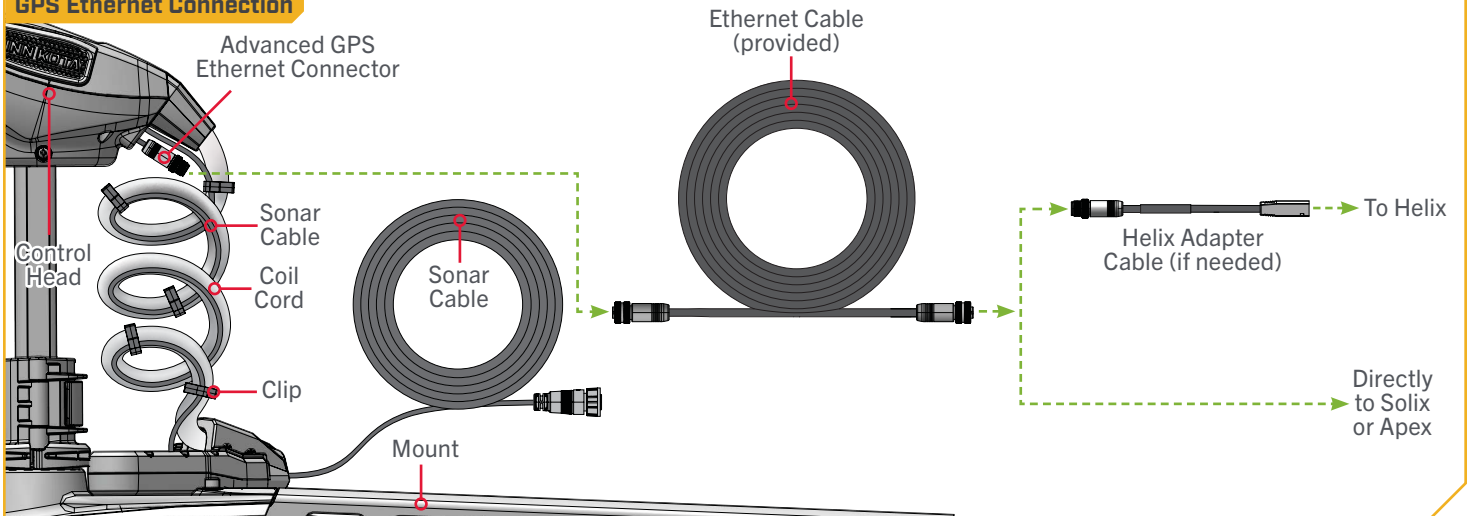

CAUTION

Failure to follow the recommended wire routing for installed features, if equipped, may cause damage to the product and void your product warranty. Route cables away from pinch points or other areas that may cause them to bend in sharp angles. Routing the cables in any way other than directed may cause damage to the cables by being pinched or severed. Do not over-tighten cable ties or clips as it may damage the wires.

1

NOTICE: Your fish finder should be turned off until this procedure is complete.

- Place the motor in the deployed position.
- Locate the Eight Pin Advanced GPS Ethernet Connector below the Control Head. The Advanced GPS Ethernet Connector will exit the base of the Control Head and will rest just below the Control Head next to the Coil Cord.

NOTICE: Ultrex QUEST trolling motors with Advanced GPS Navigation will also be equipped with Sonar. Sonar is pre-installed from the factory and may be either Dual Spectrum CHIRP or Built-in MEGA Side Imaging. With motors equipped with Sonar, a Sonar Cable will be present below the Control Head and be secured to the Coil Cord with Clips. Review the “Identifying Trolling Motor Features and Their Associated Cables” of this document to identify and learn more about Sonar.

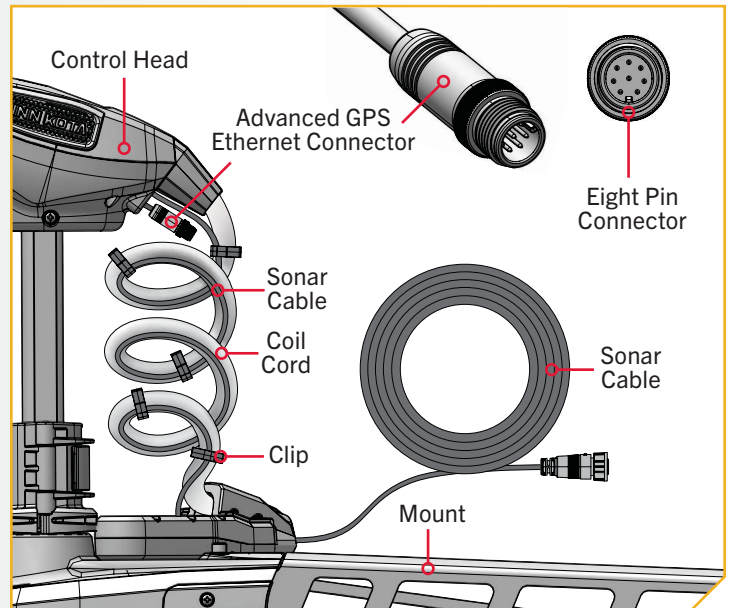

2

ITEM(S) NEEDED



- c. Take the Ethernet Cable (Item #16) and identify the Receptacle on either end. It will be keyed to fit with the Eight Pin Advanced GPS Ethernet Connector below the Control Head.

NOTICE: The Ethernet Cable has a Receptacle for the Advanced GPS Ethernet Connector on both ends and either end may be connected.

- d. Leading with either Receptacle, take the cable and run it parallel to the Coil Cord starting at the end of the Coil Cord attached to the Mount and working up towards the Control Head. The cable will run parallel to the Sonar Cable secured to the Coil Cord with Clips. Allow enough slack in the cable to attach the Receptacle to the Advanced GPS Ethernet Connector.

NOTICE: The 30' Ethernet Cable (AS EC 30E - 30' Ethernet Cable - 720073-4) is provided. If an alternate length is preferred, alternate cable lengths are available from humminbird.johnsonoutdoors.com.

NOTICE: The 30' Ethernet Extension Cable (AS ECX 30E - 30' Ethernet Extension Cable - 760025-1) is available from humminbird.johnsonoutdoors.com and should be used if the standard 30' Ethernet Cable provided with your trolling motor is not long enough to reach the fish finder.

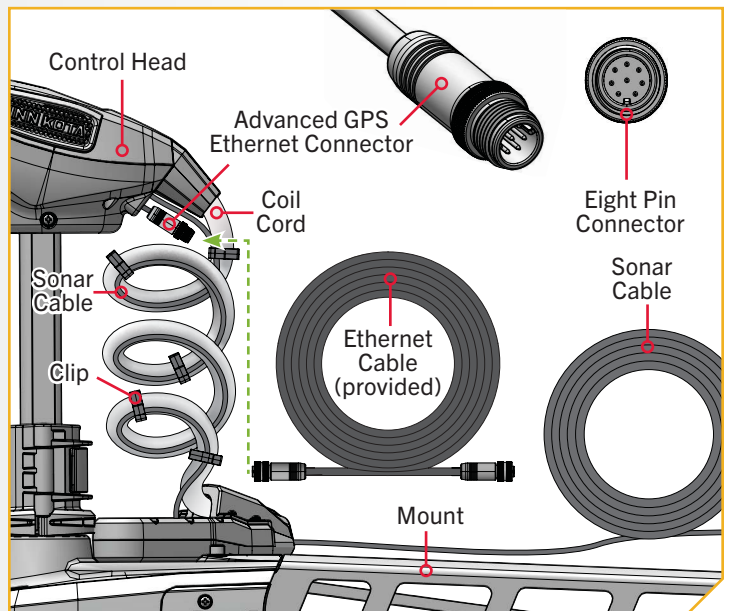
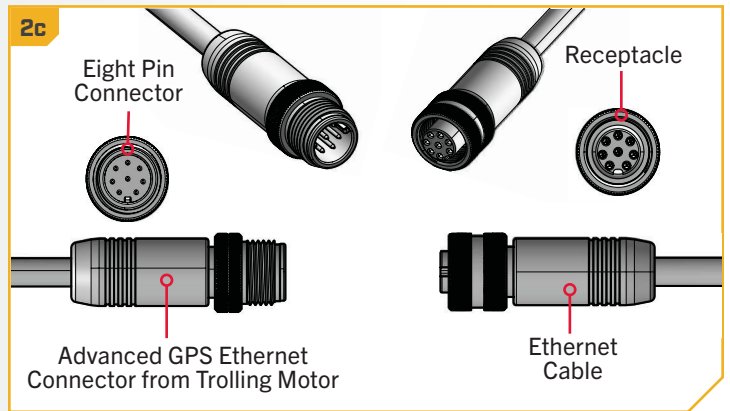

ADVANCED GPS NAVIGATION

3

NOTICE: Minn Kota recommends routing the Ethernet Cable parallel to the Coil Cord when making the Ethernet connection. The cable will be installed from the Mount to the Control Head parallel to the Coil Cord with Clips. Bypassing the Coil Cord when routing the Ethernet Cable is not recommended. After connections are made, the Ethernet Cable must be installed in the Clips. For details on securing the Ethernet Cable please follow the "Securing Connection Cables" section of this document.

NOTICE: The Advanced GPS Ethernet Connector that exits the base of the Control Head has a cap that should be removed before connecting the Ethernet Cable.

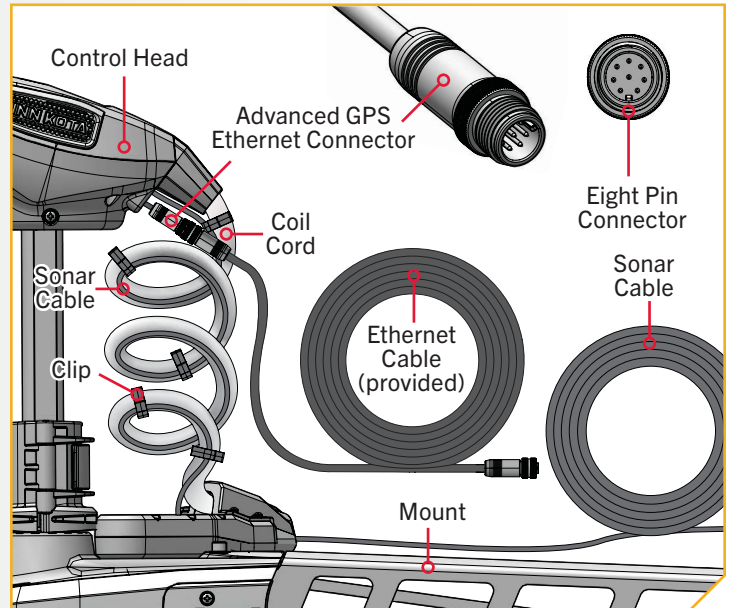

- e. **To install the Ethernet Cable**, align the pins on the Advanced GPS Ethernet Connector with the Receptacle on the Ethernet Cable. Notice the keyed connectors. Press the ends together and tighten the Collar from the Ethernet Cable to secure the connection.
- f. The Ethernet Cable will plug directly into a Solix or Apex Fish Finder or directly into a Helix Adapter Cable.

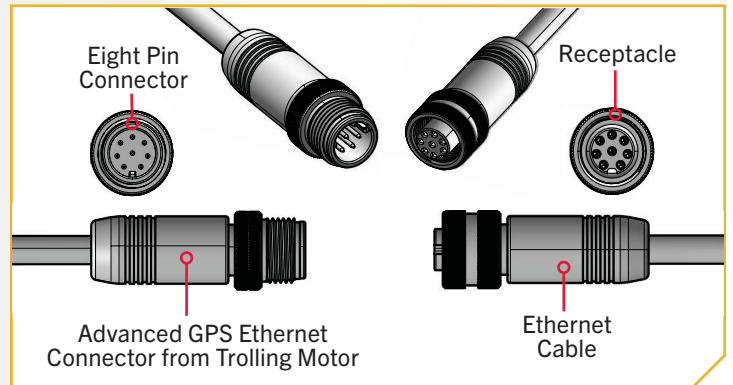

4

- g. **If installing directly to a Solix or Apex**, the connector will be flat on the back of the fish finder display.
- h. Align the Receptacle on the Ethernet Cable with the Eight Pin Connector on the Apex or Solix fish finder. Notice the keyed connectors. Tighten the Collar from the Ethernet Cable to secure the connection. Once directly installed to the Solix or Apex, the connection is complete.

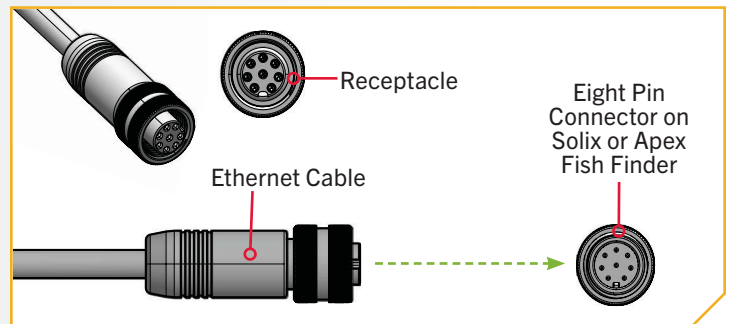

5

ITEM(S) NEEDED



- i. If installing directly to a Helix Adapter Cable (Item #18), align the Receptacle on the Ethernet Cable with the Eight Pin Connector on the Helix Adapter Cable provided. Notice the keyed connectors. Tighten the Collar from the Ethernet Cable to secure the connection.

NOTICE: Minn Kota provides one Helix Adapter Cable (AS EC QDE - Ethernet Adapter Cable - 720074-1) with every trolling motor equipped with Advanced GPS Navigation.

- j. The Helix Adapter Cable directly connects the Ethernet Cable to a Helix fish finder. Locate the Helix Adapter Cable Keyed Connector on the back of the fish finder. Plug the Helix Adapter Cable into the back of the Helix fish finder to complete the connection.
- k. If your trolling motor has more than one feature that requires connection to an output device, complete the connection for that specific output and then follow the instructions for "Securing Accessory Cables" to complete the Accessory Cable installation.

NOTICE: If unsure of what features your trolling motor may be installed with that require connection to an output device, please review the "Identifying Trolling Motor Features and Their Associated Cables" section of this manual.

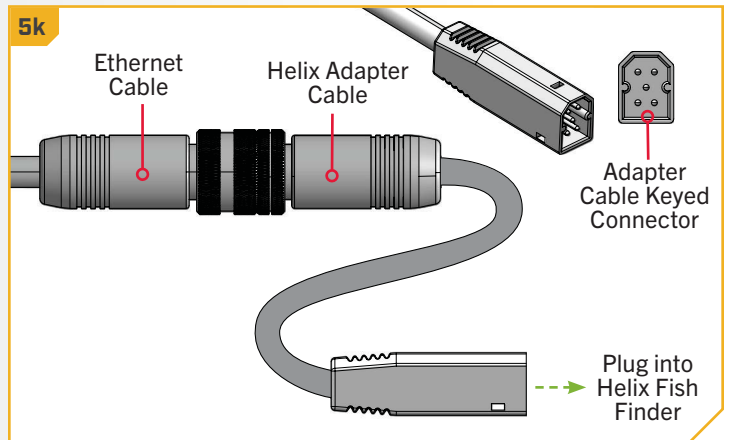
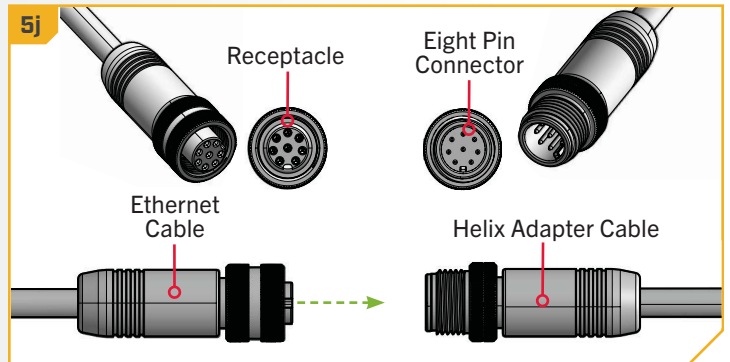

SECURING ACCESSORY CABLES

› Securing Accessory Cables

Before securing the Accessory Cables, please review the "Identifying Trolling Motor Features and Their Associated Cables" section of this document. When identifying features, it is very important to secure the cables if two or more connections are present below the Control Head. If only one cable is present below the Control Head, this installation was already completed on the trolling motors from the factory. All Accessory Cables that will be used on the trolling motor must be routed and all connections secured before completing the installation in this section. To review how Accessory Cables should be routed and connected, please review the "Dual Spectrum CHIRP", "Built-in MEGA Side Imaging" and "Advanced GPS Navigation" sections of this document.

NOTICE: If only one cable is present below the Control Head, this installation is not applicable.

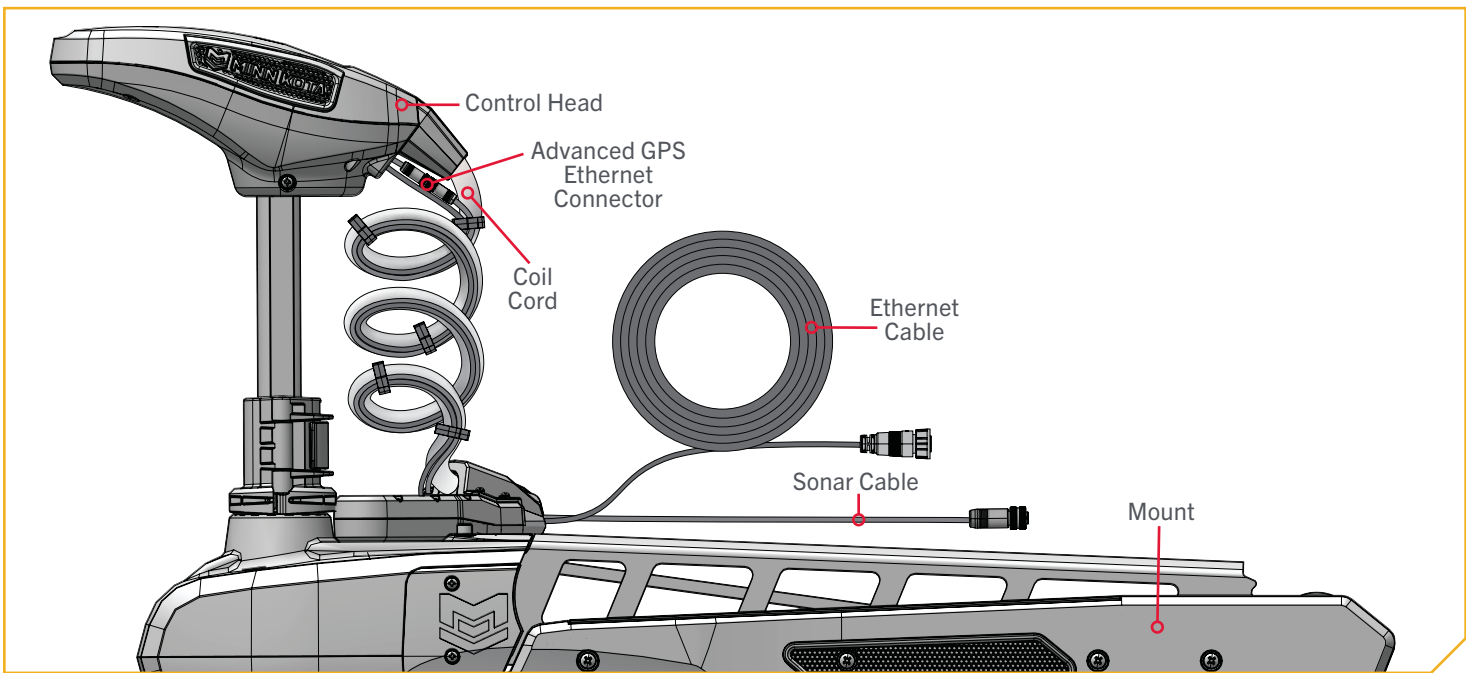

CAUTION

Failure to follow the recommended wire routing for installed features, if equipped, may cause damage to the product and void your product warranty. Route cables away from pinch points or other areas that may cause them to bend in sharp angles. Routing the cables in any way other than directed may cause damage to the cables by being pinched or severed. Do not over-tighten the clips as it may damage the wires.

NOTICE: If replacement Clips (Part No. 2290844) are needed, they can be ordered online at the Minn Kota Parts Ordering Portal at minnkota.johnsonoutdoors.com.

SECURING ACCESSORY CABLES

1

- a. The Ultrex QUEST comes from the factory with the Sonar Cable secured to the Coil Cord with five Clips. The Clips are evenly spaced down the Coil Cord from the Control Head to the Mount. To properly install the Ethernet Cable, the Clips need to be opened and the Ethernet Cable secured.
- b. Begin with the Trolling Motor in the deployed position. Locate all five Clips along the Coil Cord. Make sure that the Ethernet Cable is connected. Review the "Advanced GPS Navigation" section of this document if unsure that the Ethernet Cable is properly routed and connected. The Ethernet Cable should run parallel to the Sonar Cable down the Coil Cord.

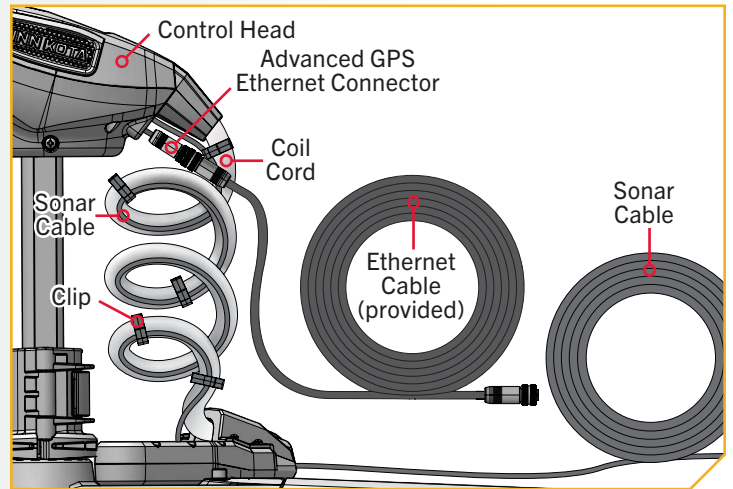

2

- c. Locate the first Clip below the Control Head. It should be securing together the Coil Cord and the Sonar Cable.
- d. To open the Clip, push each side of the Clip in opposite directions so that the hook holding the Clip together unlatches.
- e. Look at the geometry of the Clip and notice that the lobes are molded for a specific wire size. With the Ethernet Cable running parallel to the Sonar Cable and Coil Cord, place the Ethernet Cable in the Clip with the Coil Cord and Sonar Cable. Make sure that the Ethernet Cable sits in the appropriate Lobe of the Clip.
- f. Make sure the cables are running parallel and are not twisted or kinked. With all of the Cables captured, press the Clip securely closed.
- g. Repeat the installation of the Ethernet Cable for all five Clips. Make sure the cables are running smoothly between all five Clips. At the end of the installation, the Clips should be evenly spaced down the Coil Cord and the cord should contain about one Clip per coil on the Coil Cord.

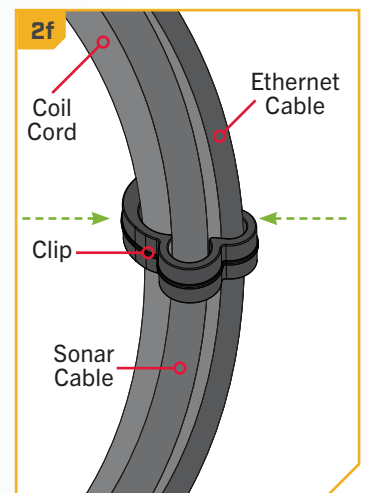
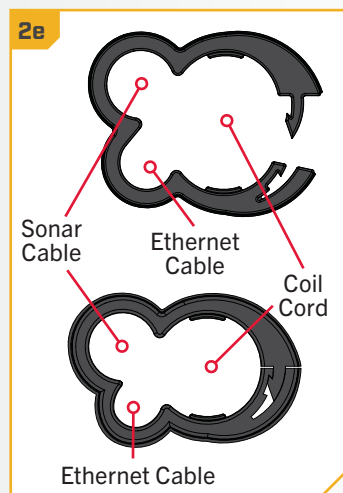
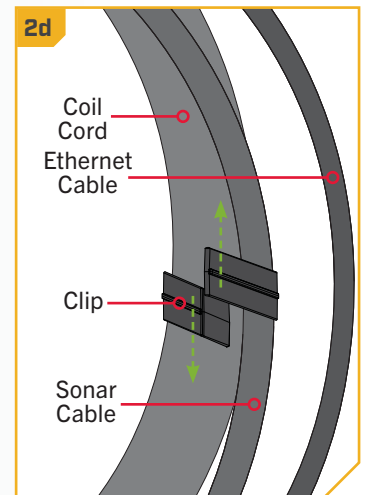
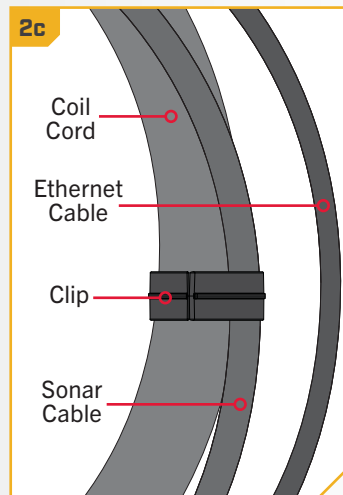

CAUTION

Do not over-tighten the Clips as it may damage the wires.

MOUNTING THE FOOT PEDAL

› Mounting the Foot Pedal

Minn Kota recommends securing the Foot Pedal to the boat deck to prevent it from being damaged during transport and to make motor operation more efficient. It is recommended to use the Mounting Holes on the Foot Pedal for a secure mount. The Foot Pedal has three Mounting Holes. One Mounting Hole is located under the Heel End of the Foot Pedal. The other two are located under the Toe End of the Foot Pedal. Minn Kota recommends using a 1/8" or 3/16" diameter screw and only tighten enough to slightly compress the Bumper Pads underneath the Foot Pedal.

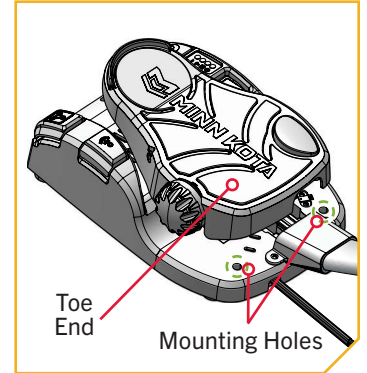
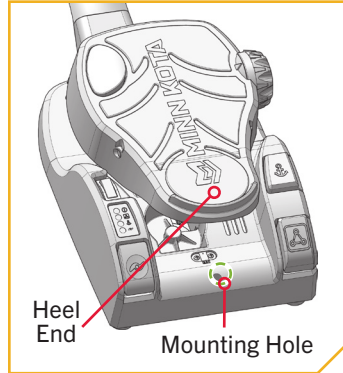

› Installing the Prop

The Ultrex QUEST trolling motor comes from the factory with two props, the Power Prop and the Weedless Wedge Prop. The Power Prop will provide maximum thrust and extra power. The Weedless Wedge Prop is 100% weedless to help move through high vegetation even at low speeds while conserving battery power. Determine which prop is best suited for the fishing environment and install it.

1

ITEM(S) NEEDED



CAUTION

Disconnect the motor from the battery before beginning any Prop work or maintenance.

- a. Take the Drive Pin (Item #44) and slide it through the Hole in the Armature Shaft. Position the Drive Pin horizontally by grasping the Armature Shaft and rotating it with the Drive Pin in place.
- b. Align the Prop (Item #38) so it is also horizontal and parallel with the Drive Pin. Slide the Prop onto the Armature Shaft and Drive Pin until it is seated against the lower unit.
- c. Install the Prop Washer (Item #40) and the Prop Nut (Item #42) onto the end of the Armature Shaft.

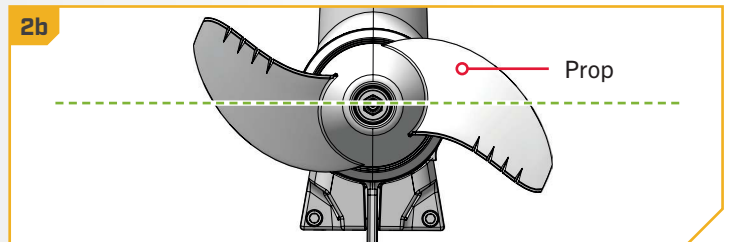
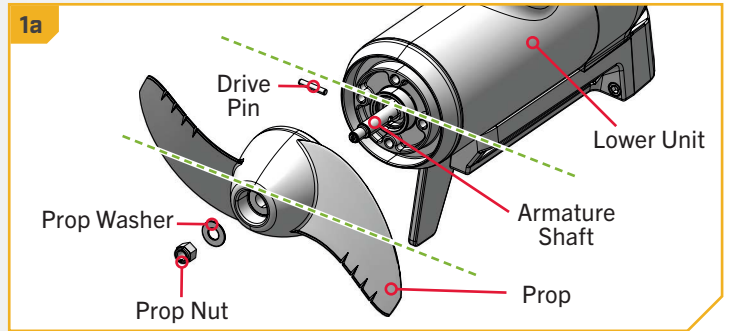

2

- d. While holding the Prop horizontal, tighten the Prop Nut with a 9/16" Deep Well Socket.
- e. Tighten the Prop Nut to 25-35 in-lbs.

 **CAUTION**

Do not over-tighten as this can damage the prop.

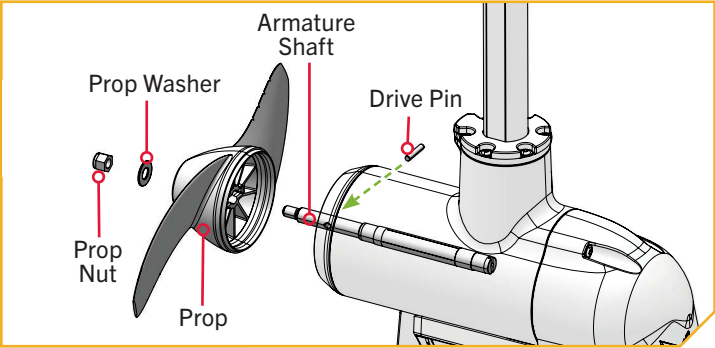

ONE-BOAT NETWORK

OPTIMIZING THE PERFORMANCE OF THE ULTREX QUEST WITH THE ONE-BOAT NETWORK APP

Minn Kota® and Humminbird® have joined forces to bring you the One-Boat Network (OBN). To get the most from your One-Boat Network, we encourage you to download the One-Boat Network app onto your smart device. The One-Boat Network® app is a free iOS and Android application that you can download to a mobile device, providing unparalleled control over all of your One-Boat Network connected products.

Completing the installation of the Ultrex QUEST through the One-Boat Network app should be done following the Prop installation. Recheck the OBN settings once the boat is trailered and the motor is used on the water. Minn Kota recommends connecting the trolling motor to the One-Boat Network app to assist in these steps. Find more information in the One-Boat Network app document included with the trolling motor or the One-Boat Network Owner's Manual found online at minnkota.johnsonoutdoors.com. Before beginning, be sure that the trolling motor is connected to a power source.



One-Boat Network app Icon



WARNING

Take care that neither you nor other persons approach the turning propeller too closely, neither with body parts nor with objects. The motor is powerful and may endanger or injure you or others. Stay clear of the Prop and watch out for accidental engagement.

ONE-BOAT NETWORK ADJUSTMENTS >

> Keel Offset

The Ultrex QUEST comes from the factory with the Lower Unit parallel to the Mount. When the Lower Unit is parallel to the Mount, the Keel Offset is zero. In an ideal installation, the Lower Unit will be parallel to the Keel, however, the Mount is rarely installed to be perfectly in-line with the Keel, therefore the Lower Unit will not be parallel with the Keel. Nearly all installations will have some variation in mounting position to either the Port or Starboard side of the boat. During installation, indexing the trolling motor corrects the position of the Foot Pedal to be parallel to the boat deck when the Lower Unit is parallel to the Keel. The Keel Offset feature records the position of the Lower Unit when it is parallel to the Keel and when the Foot Pedal is also parallel based on the Mount being offset from the Keel. Before adjusting the Keel Offset, complete all installation steps. This includes mounting the trolling motor to the deck of the boat, calibrating or rotating the Pedal Control Sleeve Assembly, and installing and securing the power and accessory cables. The Keel Offset is specified on the Ultrex QUEST through the One-Boat Network App with the Keel Mount Offset. Minn Kota recommends using the One-Boat Network app to complete the Keel Offset procedure. If the app is unavailable, Keel Offset can be set using a Humminbird Helix, Apex or Solix fish finder. If completing Keel Offset with the fish finder, please see the Owner's Manual for more information.

NOTICE: When the motor is installed from the factory, the motor Keel Offset is 0 degrees. When setting the Keel Offset, any position towards the Port will create a Keel offset of a negative angle. Any position towards Starboard will create a positive angle.

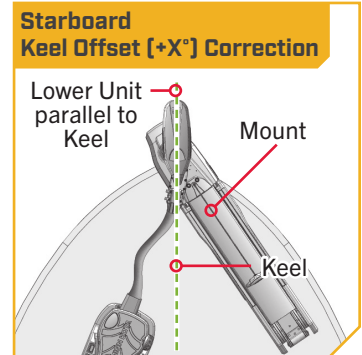
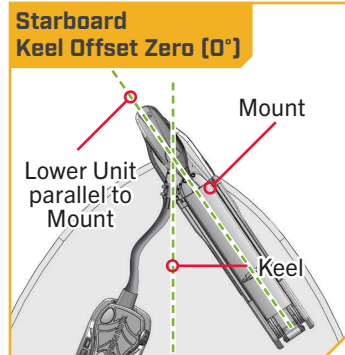
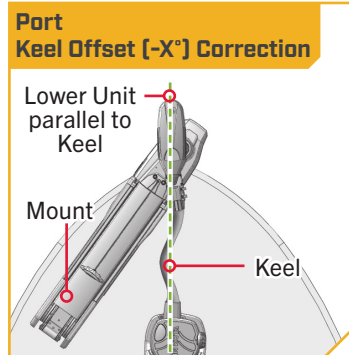
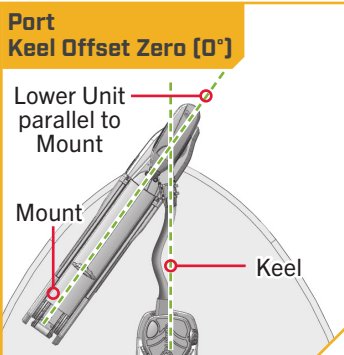

1

- Power on the trolling motor. When the blue LED next to the power icon is “on”, the system is ready.
- With either the One-Boat Network app on a paired mobile device, or the foot pedal, steer the motor so that the control head and lower unit are parallel to the Keel.

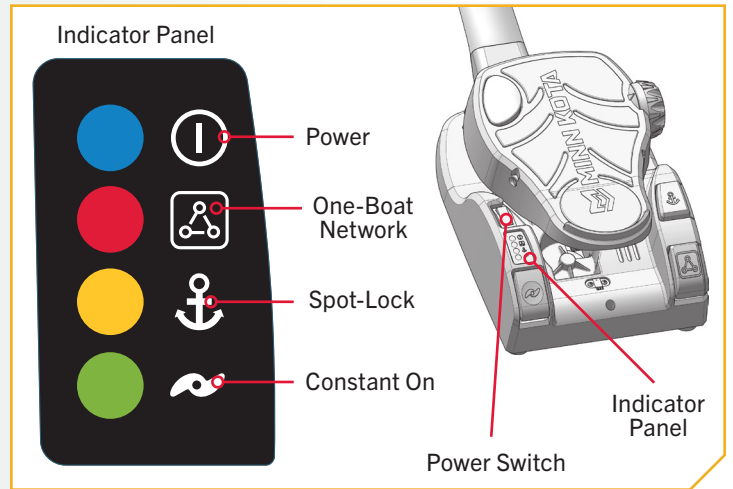
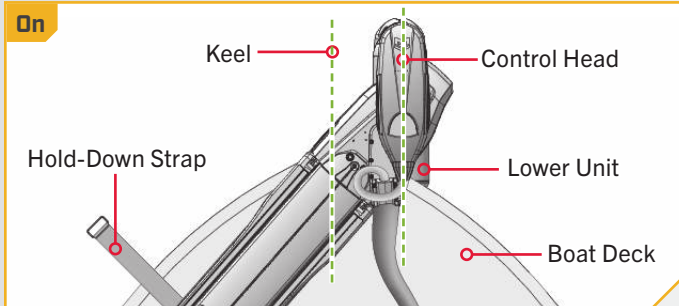

2

- Open the One-Boat Network (OBN) app on the mobile device. Make sure the mobile device is paired with the trolling motor.
- From the OBN home screen, tap the Motor menu. The Motor menu opens the Motor app home screen.
- Before the Motor app home screen will open, tap Agree on the on-screen prompt.

NOTICE: The on-screen prompt will only display once each time the app is launched. If the prompt has displayed, the Motor app home screen appears.

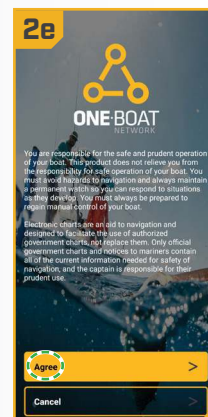
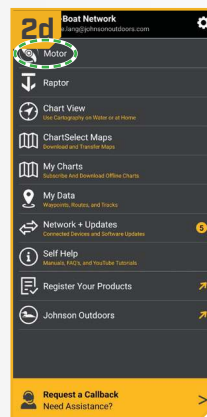

- On the Motor app home screen, locate the Motor Setting button in the upper right-hand corner and tap it.

3

- In the Motor Settings menu, find and tap Setup and Calibration.
- In Setup and Calibration, find and tap Keel Mount Offset.
- Review all safety warnings. Follow the prompts in the One-Boat Network app. If the placement of the trolling motor is pointing forward and parallel to the keel, tap Set. The degree of Keel Mount Offset shows at the bottom of the app Display.

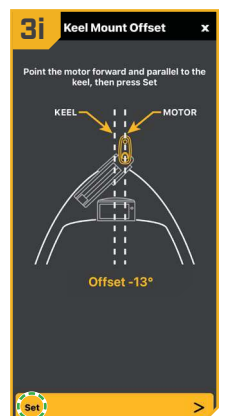
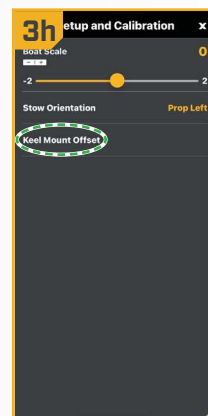
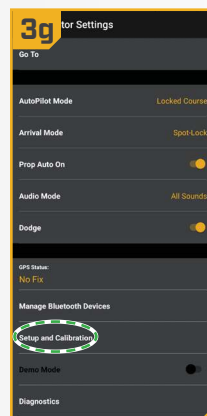

STRAIGHT ON DEPLOY

4

- j. If the trolling motor needs to be adjusted, locate the Return button on the top-left corner of the app screen. Tap the Return button three times until the Motor app home screen displays.
- k. Use the Steer Right > and Steer Left < buttons to point the motor forward and parallel to the keel.
- l. When satisfied with the placement of the trolling motor, locate the Motor Settings button in the top-right corner and tap it.
- m. In the Motor Settings menu, find and tap Setup and Calibration.
- n. In Setup and Calibration, find and tap Keel Mount Offset. If the placement of the trolling motor is pointing forward and parallel to the keel, tap Set.
- o. The degree of Keel Mount Offset shows at the bottom of the app Display. Tap Return to close the Keel Mount Offset and return to the home screen.

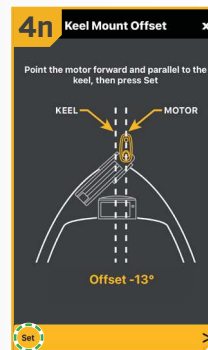
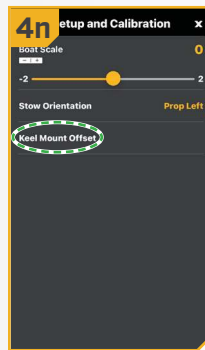
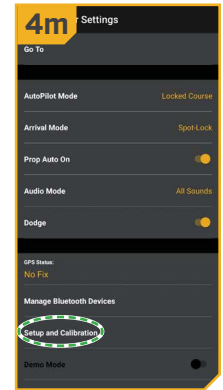
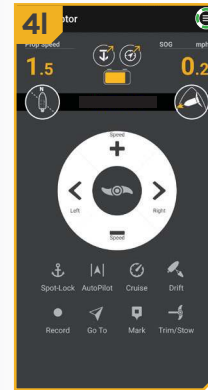
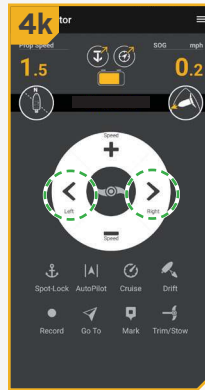

› Straight on Deploy

Minn Kota recommends setting the Keel Offset when the position of the Lower Unit is parallel with the Keel. Save the Keel Offset before exploring the Straight on Deploy feature. Straight on Deploy uses the position recorded in Keel Offset to know where to position the Lower Unit to be parallel with the Keel. When Straight on Deploys is engaged, the trolling motor will deploy the motor and automatically rotate the Lower Unit to the position saved to memory in Keel Offset. By default, the Lower Unit will be parallel to the Keel when the Mount is parallel to the Keel. If the Keel Offset was programmed to another angle, the Straight on Deploy feature will correct the position to match the corrected angle when turned “on”. If straight on deploy is turned “off” the trolling motor will not correct the position in any direction.

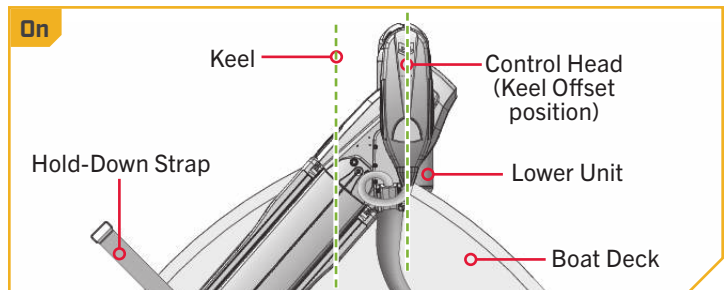
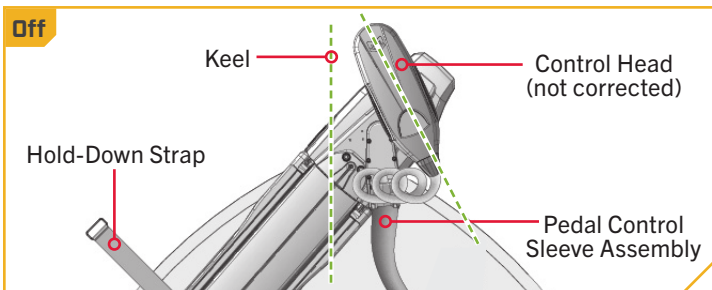

1

- a. Power "on" the trolling motor. When the blue LED next to the Power icon is illuminated, the system is ready.

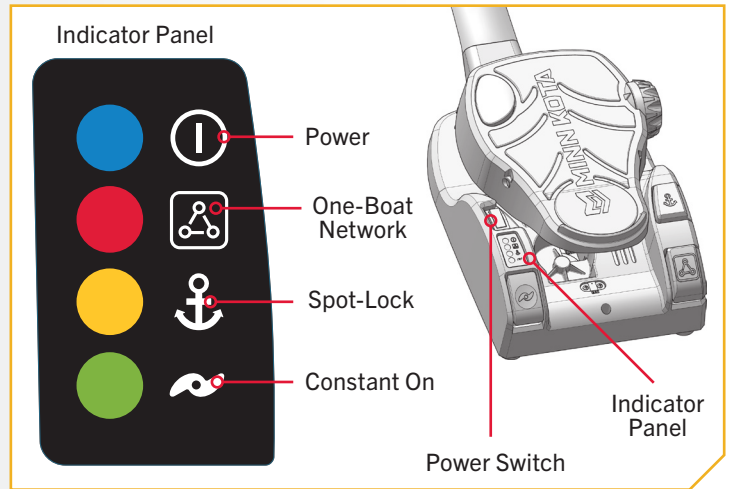

2

- b. Open the One-Boat Network (OBN) app on the mobile device. Make sure the mobile device is paired with the trolling motor.
- c. From the OBN home screen, tap the Motor menu. The Motor menu opens the Motor app home screen.
- d. Before the Motor app home screen will open, tap Agree on the on-screen prompt.

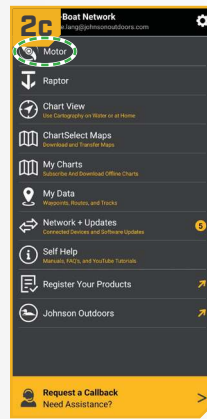

NOTICE: The on-screen prompt will only display once each time the app is launched. If the prompt has displayed, the Motor app home screen appears.

- e. On the Motor app home screen, locate the Motor Setting button in the upper right-hand corner and tap it.

3

- f. In the Motor Settings menu, find the Straight Ahead on Deploy toggle. Tap to turn the toggle "on" and "off". When highlighted yellow the toggle is "on".

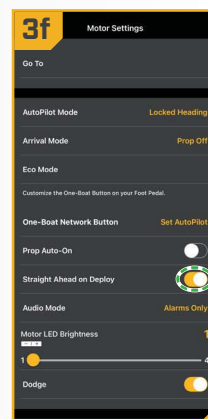
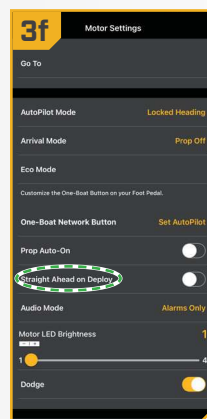

STOW ORIENTATION

Stow Orientation

The Stow Orientation is a term used to describe the lower unit and Prop position when the motor is stowed. The lower unit will automatically rotate into the Stow Orientation when stowing the motor. The Stow Orientation can be set to Prop Left or Prop Right through the Wireless Remote or One-Boat Network app. The factory default setting for the lower unit is Prop Left. Adjusting the Stow Orientation allows the installation to be customized to fit boat positioning for either a Port or Starboard installation and to accommodate fishing or trailering applications.

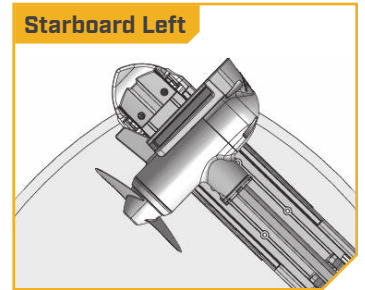
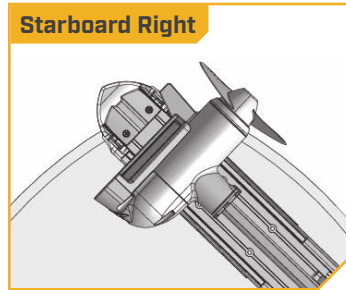
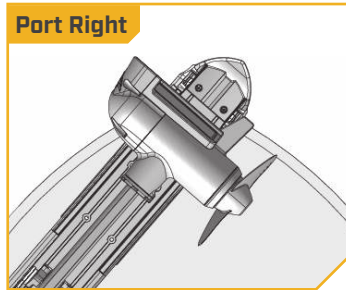
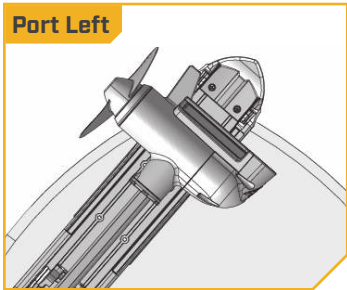

- 1 a. Power "on" the trolling motor. When the blue LED next to the Power icon is illuminated, the system is ready.

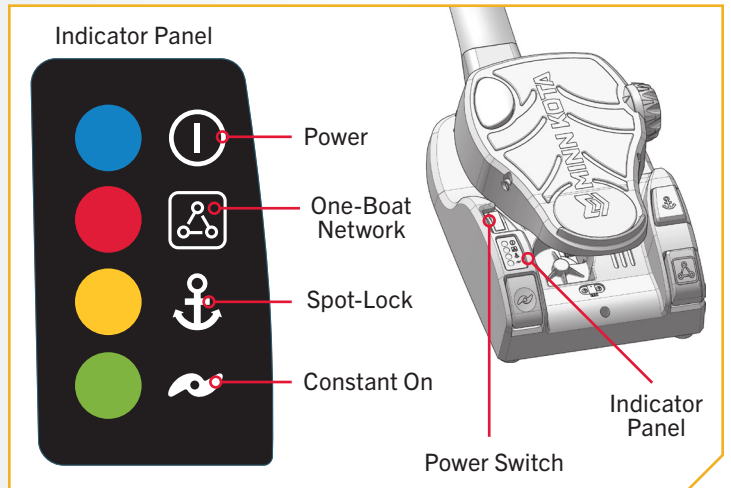

- 2 b. Open the One-Boat Network (OBN) app on the mobile device. Make sure the mobile device is paired with the trolling motor.
- c. From the OBN home screen, tap the Motor menu. The Motor menu opens the Motor app home screen.
- d. Before the Motor app home screen will open, tap Agree on the on-screen prompt.

NOTICE: The on-screen prompt will only display once each time the app is launched. If the prompt has displayed, the Motor app home screen appears.

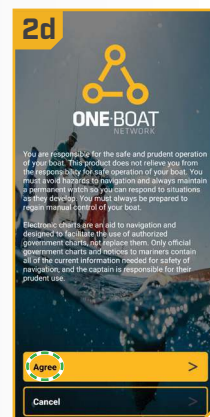
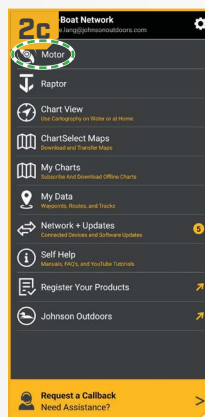

- e. On the Motor app home screen, locate the Motor Setting button in the upper right-hand corner and tap it.

- 3**
- f. In the Motor Settings menu, find and tap Setup and Calibration.
 - g. In Setup and Calibration, find and tap Stow Orientation.
 - h. Set the feature to Prop Right or Prop Left.

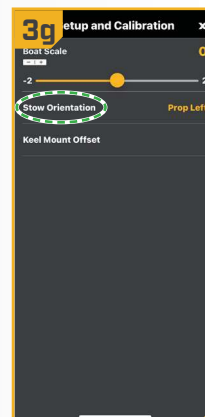
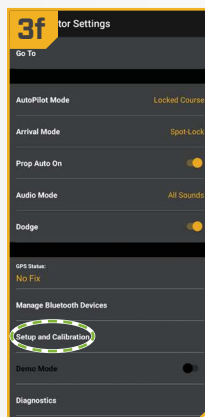

Boat Scale

Trolling motor performance can be impacted by factors including, but not limited to, wind, water conditions, boat specifications, battery health, wiring, etc.

Boat Scale provides a method of adjusting how the trolling motor will perform to account for these and other variables. The Minn Kota trolling motor comes from the factory with Boat Scale set to zero. Boat Scale can be adjusted up (+2) or down (-2) to increase or decrease how the motor control software applies power while using a navigation mode like Spot-Lock.

An example showing the need to reduce Boat Scale would be while using Spot-Lock and the motor is over-correcting or making frequent adjustments. In this case, try reducing Boat Scale to -1 to reduce this behavior. If the behavior continues, reduce Boat Scale to -2.

An example showing the need to increase Boat Scale while using Spot-Lock would be the motor is drifting away from its target location frequently or needs help to make corrections. Try increasing Boat Scale to +1 to help improve the trolling motor accuracy in this case. If the behavior continues, increase Boat Scale to +2.

- 1**
- a. Power "on" the trolling motor. When the blue LED next to the power icon is illuminated, the system is ready.

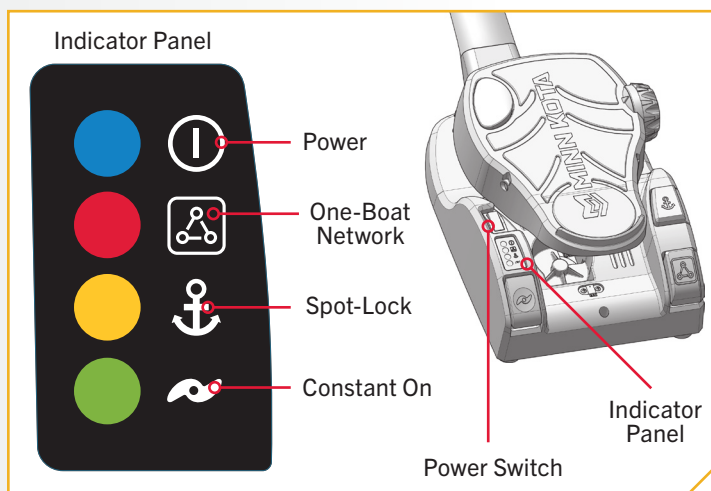

BOAT SCALE

2

- b. Open the One-Boat Network (OBN) app on the mobile device. Make sure the mobile device is paired with the trolling motor.
- c. From the OBN home screen, tap the Motor menu. The Motor menu opens the Motor app home screen.
- d. Before the Motor app home screen will open, tap Agree on the on-screen prompt.

NOTICE: The on-screen prompt will only display once each time the app is launched. If the prompt has displayed, the Motor app home screen appears.



- e. On the Motor app home screen, locate the Motor Setting button in the upper right-hand corner and tap it.

3

- f. In the Motor Settings menu, find and tap Setup and Calibration.
- g. In Setup and Calibration, find and tap the Boat Scale.
- h. Set the feature to increase or decrease Boat Scale.

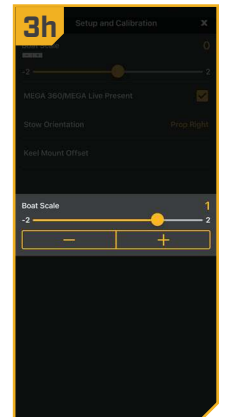
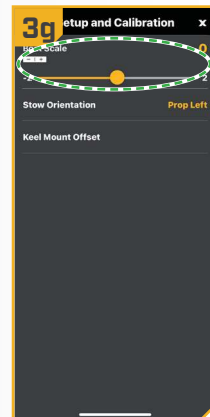
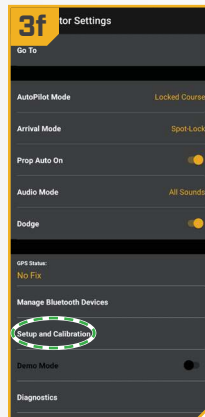

CUSTOMIZE ONE-BOAT NETWORK BUTTON ON THE FOOT PEDAL

› Customize One-Boat Network Button on the Foot Pedal

Minn Kota trolling motors equipped with Advanced GPS Navigation are compatible with devices enabled with the One-Boat Network, such as the Foot Pedal. The One-Boat Network button can be customized through either the One-Boat Network app on a paired mobile device or the Advanced GPS Navigation Wireless Remote. One-Boat Network functions are enabled and disabled through the Foot Pedal with the One-Boat Network  button. The One-Boat Network button on the Foot Pedal can be customized to control the following functions:

Function	Operation	LED Indication
AutoPilot (default)	Engage and disengage AutoPilot	Red LED will illuminate when AutoPilot is engaged and stay on until disengaged.
Waypoint	Mark a Waypoint	Red LED will illuminate when the One-Boat Network button is pressed and then turn off, signaling that a Waypoint was marked.
Shallow Water Anchor (Raptor/Talon)	Deploy and retract a Raptor/Talon	Red LED will steadily flash when the Shallow Water Anchor is deploying or stowing. Red LED will stay illuminated when the anchor is at any state of deployment, including when it is paused. Red LED will turn off when the anchor is fully stowed.

1

- With the trolling motor on, open the One-Boat Network (OBN) app on the mobile device. Make sure the mobile device is paired with the trolling motor.
- From the OBN home screen, tap the Motor menu. The Motor menu opens the Motor app home screen.
- Before the Motor app home screen will open, tap Agree on the on-screen prompt.

NOTICE: The on-screen prompt will only display once each time the app launches. If the prompt has been displayed, the Motor app home screen appears.

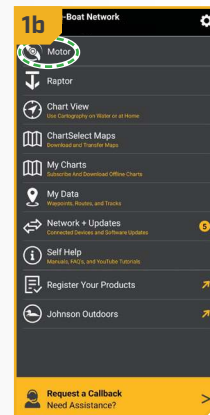
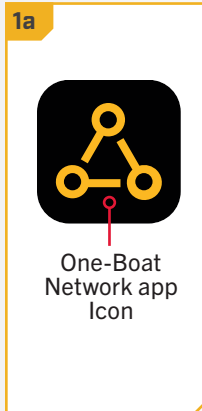

CUSTOMIZE ONE-BOAT NETWORK BUTTON ON THE FOOT PEDAL

2

- d. On the Motor app home screen, locate the Motor Settings button in the top-right corner and tap it.
- e. On an Android, in Motor Settings, locate “One-Boat Network Button” and tap it.
- f. On iOS, in Motor Settings, locate “Foot Pedal” and tap it.
- g. In the One-Boat Network Button menu, choose the desired function. The radio button next to the selected function will be highlighted.

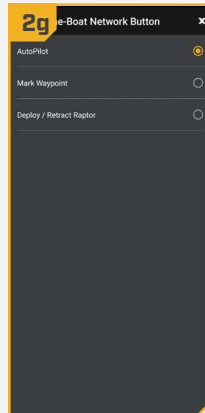
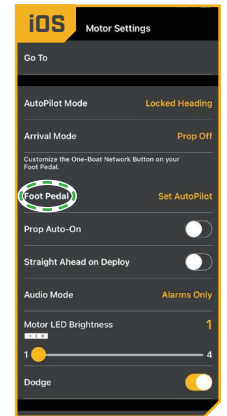
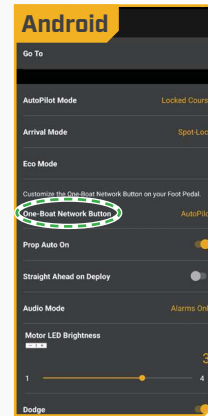
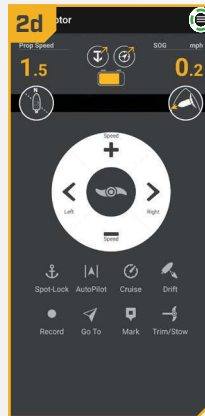

This completes the installation of your Ultrex QUEST. A complete Owner’s Manual can be downloaded at minnkota.johnsonoutdoors.com.

RECOMMENDED ACCESSORIES

ON-BOARD & PORTABLE BATTERY CHARGERS

Stop buying new batteries and start taking care of the ones you've got. Many chargers can actually damage your battery over time – creating shorter run times and shorter overall life. Digitally controlled Minn Kota chargers are designed to provide the fastest charge that protect and extend battery life.



MK212PCL



MK210D



MK110PD

TALON SHALLOW WATER ANCHOR

Talon is the only shallow water anchor with up to 15' of anchoring depth, multiple anchoring modes, and control from the bow, transom, console, remote or mobile device.



BUILT-IN WORK LIGHT

Lets you tie lines and work from the transom any time of day — or night. Includes both white and blue LED lights with three brightness settings.



UP TO 15' DEEP

Control more water and catch more fish with the first 15' shallow water anchor.



MORE CONTROL OPTIONS

- Control Panel
- Wireless Remote
- Mobile App
- Wireless Foot Switch
- Humminbird® Connectivity
- Advanced GPS Navigation System Remote



BLUETOOTH® CONNECTIVITY

Lets you control Talon from your mobile device and easily update it. Also opens up communication to other control options.

MINN KOTA ACCESSORIES

We offer a wide variety of trolling motor accessories, including:

- 60-Amp Circuit Breaker
- Mounting Brackets
- Stabilizer Kits
- Extension Handles
- Battery Connectors
- Battery Boxes
- Quick Connect Plugs



minnkota.johnsonoutdoors.com    

Part #2297167

Minn Kota Consumer & Technical Service
Johnson Outdoors Marine Electronics, Inc.
PO Box 8129
Mankato, MN 56001

ECN 44760

121 Power Drive
Mankato, MN 56001
Phone (800) 227-6433
Fax (800) 527-4464



©2024 Johnson Outdoors Marine Electronics, Inc.
All rights reserved.

Rev F

03/24