

## ETHERNET BLACK BOX SONAR Installation Guide

531812-1\_B

### OVERVIEW

The Ethernet Black Box Sonar allows you to connect select transducers and accessories to your SOLIX®, ONIX®, or ION® control head. Connect up to two Black Box Sonars on your Ethernet network.

#### Example of a Black Box Sonar Configuration

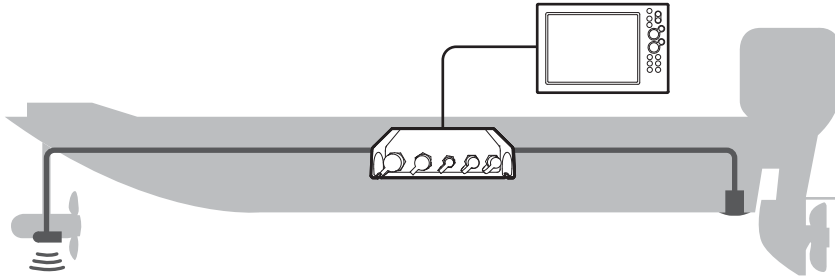

**NOTE:** To review and/or purchase compatible accessories for your control head configuration, visit our Web site at [humminbird.com](http://humminbird.com) or contact Customer Service.

### PREPARATION

Following are instructions for the installation of this accessory. Before you start the installation, we encourage you to read these instructions carefully in order to get the full benefit from your Humminbird® accessory.



**NOTE:** The illustrations in this manual may not look the same as your product, but your unit will function in the same way.

**Customer Service:** If you find that any items are missing from your installation kit, visit our Web site at [humminbird.com](http://humminbird.com) or call Customer Service at **1-800-633-1468**.

**Supplies:** In addition to the hardware supplied with your installation kit, you will need a powered hand drill, a 1/8" drill bit, a Phillips screwdriver, a level, a pencil, tape or heat-shrink insulation, and a Humminbird Ethernet cable [separate purchase required]. You may also need an adapter cable [separate purchase required] if you plan to connect a previously installed transducer.

### INSTALLATION

Perform the procedures in the following sections to install the Black Box Sonar on your boat.

#### 1 | Determine the Mounting Location

The Black Box Sonar is designed to mount on any flat, level surface of your boat. Prior to installation, you must first determine where to mount the Black Box Sonar.

1. Use a level to locate a suitable, flat area to mount the Black Box Sonar.
2. Place the Black Box Sonar in the chosen mounting location and test the length of the cables [transducer, temp/speed, and power] to confirm that each cable will reach the Black Box Sonar.
3. Test the length of the Ethernet cable [separate purchase required] from the Black Box Sonar to confirm it will reach the control head.





**CAUTION!** Do NOT mount the cables where the connectors could be submerged in water or flooded. If cables are installed in a splash-prone area, it may be helpful to apply dielectric grease to the inside of the connectors to prevent corrosion. Dielectric grease can be purchased separately from a general hardware or automotive store.

**2 | Install the Black Box Sonar**

Once you have determined the mounting location, perform the following procedures to install the Black Box Sonar on your boat.

1. Set the Black Box Sonar in place on the mounting surface. Mark the four mounting screw locations with a pencil.
2. Set the Black Box Sonar aside, and drill the four mounting holes using a 1/8" drill bit.

 **NOTE:** On fiberglass hulls, it is best to use progressively larger drill bits to reduce the chance of chipping or flaking the outer coating.

 **NOTE:** If the mounting surface is thin or made of a lightweight material, you may need to add reinforcing material below the mounting surface in order to support the Black Box Sonar.

3. Insert the rubber feet (included), with the adhesive side facing down, into the four circular recesses on the bottom of the Black Box Sonar. See the illustration *Inserting the Rubber Feet*.
4. Place the Black Box Sonar on the mounting surface and align the screw holes with the drilled mounting holes. Insert the four #10 screws (included) through the screw holes and into the drilled mounting holes, and hand-tighten using a Phillips screwdriver. **Hand-tighten only!**

 **NOTE:** Apply marine-grade silicone caulk or sealant (separate purchase required) to both screws and drilled holes as needed to protect your boat from water damage.

**3 | Connect the Ethernet Cable**

The Ethernet cable can be connected directly to the control head or to an additional Black Box Sonar or Ethernet Switch on your network. Refer to your Ethernet Networking manual and the control head installation guide for more information.

1. Unscrew the Ethernet port cover on the Black Box Sonar. Connect the Ethernet cable connector to the port. Hand-tighten the screw nut to secure the cable connection.
2. **Control Head:** Connect the Ethernet cable connector to the Ethernet port on the back of the control head.

**Black Box Sonar:** Connect the Ethernet cable connector to the Ethernet port.

**Ethernet Switch:** Connect the Ethernet cable connector to an Ethernet port.

 **NOTE:** See the Ethernet Switch installation guide for more details.

3. Hand-tighten the screw nut to secure the cable connection.

 **NOTE:** Make sure the port covers are tightly fastened over any unused connector ports. Connectors that are left exposed may corrode.

**4 | Connect the Airmar® Temp/Speed Cable**

If you have the Airmar Speed and Temperature Paddlewheel Accessory, see the instructions below to connect the cable to the Black Box Sonar. Also, see the installation guide included with the accessory.

1. Unscrew the Speed/Temp port cover on the Black Box Sonar.
2. Connect the Speed/Temp cable connector to the Speed/Temp port. Hand-tighten the screw nut to secure the cable connection.

**Inserting the Rubber Feet**  
rubber feet

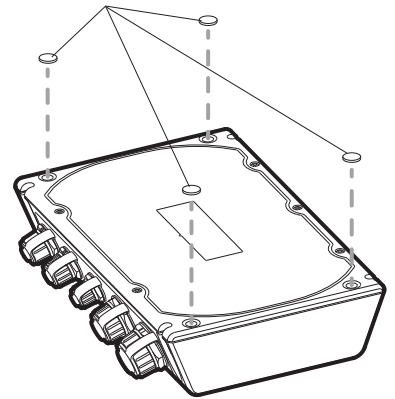

**Installing the Black Box Sonar**

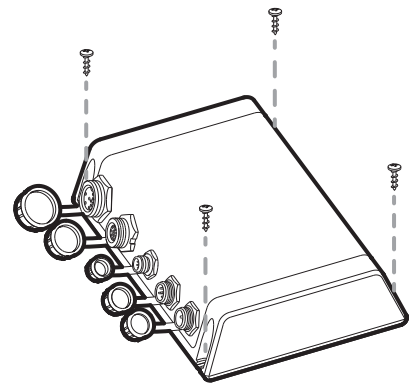

**Connecting Cables to the Black Box Sonar**  
(SM 3000 displayed below)

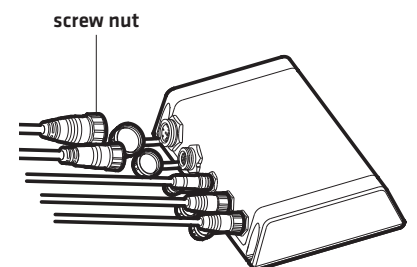

 **NOTE:** The connector ports are keyed to prevent reversed installation, so be careful not to force the connector into the port.

## 5 | Connect Transducer Cables



**NOTE:** Some Airmar and previously installed Humminbird transducers may require an adapter cable to connect to the Black Box Sonar. For more information, visit our Web site at [humminbird.com](http://humminbird.com) or Airmar's Web site at [airmartechology.com](http://airmartechology.com).

1. See the table below to determine the port connection[s] for your transducer type[s] and Black Box Sonar model.

Transducer Type	SM 1000 Port Connection	SM 2000 Port Connection	SM 3000 Port Connection
Airmar 2D Sonar	2D Sonar	2D Sonar	Broadband
Humminbird 2D Sonar	—	SI/DI/2D Sonar	SI/DI/2D Sonar
Humminbird Side Imaging® or Down Imaging®*	—	SI/DI/2D Sonar	SI/DI/2D Sonar
Airmar CHIRP**	—	—	Broadband

\*MEGA Imaging™ transducers can be connected to the Black Box Sonar, but MEGA Imaging frequencies are not supported.

\*\*The Airmar CHIRP transducer requires an adapter cable to connect to the Black Box Sonar. See the instructions in the next section to connect the adapter cable and CHIRP transducer cable to the Black Box Sonar.

2. Unscrew the port cover on the Black Box Sonar.
3. Connect the transducer cable connector to the port.
4. Hand-tighten the screw nut to secure the cable connection.

## 6 | Connect the CHIRP Transducer Adapter Cable [SM 3000 only]

If you plan to connect an Airmar CHIRP transducer, use the following instructions to connect it to the CHIRP adapter cable [included with the SM 3000]. Also, see the installation guide included with the Airmar CHIRP transducer.



**WARNING!** Turn off power for all related equipment before you start the installation.

1. Turn off the power for the Humminbird control head and each connected accessory.
2. See the installation guide included with the Airmar CHIRP transducer to confirm the wiring and that the bare wire colors match those shown in the following table.



**WARNING!** Your CHIRP transducer may have different wiring. It is important to refer to the guide included with your transducer to confirm the wiring and cable connections.

3. Connect the adapter cable wires to the CHIRP transducer cable wires as shown in the following table. Tape or apply heat-shrink insulation to each connection to prevent shorting the wiring.



**NOTE:** To protect the wire connections, use a junction or break-out box (separate purchase required).

## ETHERNET BLACK BOX SONAR Installation Guide

CHIRP Adapter Cable Wires	Airmar CHIRP Transducer Cable Wires	Functionality
Orange	Blue	High Frequency Pair
Orange & White	Black	
Brown	Blue & White	Low Frequency Pair
Brown & White	Black & White	
Green	Orange	XID
Green & White	White	Temperature
Drain (unshielded wires)	Drain & Brown	Ground/Drain

**NOTE:** Items labeled as High Frequency Pair refer to the higher of two given frequencies. Items labeled as Low Frequency Pair refer to the lower of two given frequencies. For example, a Low & Medium Frequency CHIRP transducer would use the medium frequencies as the High Frequency Pair and the low frequencies as the Low Frequency Pair.

- Unscrew the Broadband port cover on the Black Box Sonar.
- Connect the adapter cable connector to the port. Hand-tighten the screw nut to secure the cable connection.

### 7 | Connect the Power Cable

The Black Box Sonar power cable (included) can be connected to the electrical system of the boat at two locations: a fuse panel (usually located near the console) or directly to the battery.

**CAUTION!** Make sure that the power cable is disconnected from the Black Box Sonar at the beginning of this procedure.

**NOTE:** Humminbird is not responsible for over-voltage or over-current failures. The Black Box Sonar must have adequate protection through the proper selection and installation of a 5 amp fuse (separate purchase required).

- Refer to the table, **Determine Your Voltage Requirement**, to confirm the voltage requirement for your Fishing System.
- If a fuse terminal is available, use crimp-on type electrical connectors (not included) that match the terminal on the fuse panel. Depending on your control head model, attach the black wire to ground [-] and the red wire to positive [+] 12 VDC or 24 VDC power (see **Determine Your Voltage Requirement**). Install a 5 amp fuse (not included) for the protection of the accessory. Humminbird is not responsible for over-voltage or over-current failures.

or...

  - If you need to wire the power cable directly to a battery, obtain and install an inline fuse holder and a 5 amp fuse (not included) for the protection of the accessory. Attach the black wire to ground [-] and the red wire to positive [+]. Humminbird is not responsible for over-voltage or over-current failures.
- Connect the power cable connector to the port labeled POWER on the Black Box Sonar. The ports are keyed to prevent reversed installation, so be careful not to force the connector into the connector port. Hand-tighten the screw nut to secure the cable connection.
- Install cable ties (separate purchase required) to prevent the cables from moving and pulling, which could stress and potentially damage the cable connectors.

Proceed to the **Set up Transducers and Select Sonar Sources** section to set up your transducer source on the control head.

#### Determine Your Voltage Requirement

Model	Voltage
SOLIX	12 VDC
ONIX	12 VDC
ION	12 VDC or 24 VDC

#### Connecting the Power Cable

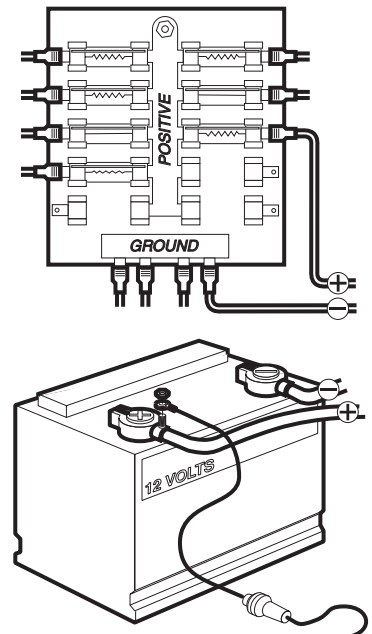

## SET UP TRANSDUCERS AND SELECT SONAR SOURCES (OPTIONAL)

Transducers with ID or XID [Airmar transducers] are configured automatically in the system, and the control head will automatically select the best sonar source based on transducer capabilities. Sonar source information is available in your control head operations manual.

 **NOTE:** To set up a transducer manually [Initial Setup], change sonar sources, or troubleshoot sonar sources, download the Transducer Setup Guide from our Web site at [humminbird.com](http://humminbird.com).

### Open the Sonar Source Menu

Use the following instructions to open the Sonar Source Menu, where you can select sonar sources, set the max depth and depth offset, and select other sonar settings for your connected transducers.

1. Press the HOME key.
2. Select Settings.
3. Select Sonar to access Noise Filter and individual Beam Select.
4. Select Sonar Source to set up transducers and choose sonar sources.

## SET AIRMAR CHIRP SETTINGS (OPTIONAL)

Use the following instructions to set up transmit mode, sweep, frequency range, and other operation preferences. The menus in this section are determined by the type of CHIRP transducer installed.

1. Press the HOME key.
2. Select Settings.
3. Select Sonar.
4. Scroll to the CHIRP SONAR section to adjust the following menu settings:

<b>Transmit Mode</b>	<p>Select <b>Spectrum Sweep</b> to transmit the transducer beams in a sweeping range. To set the sweep range see <i>Low/Medium/High Frequency Spectrum</i>.</p> <p>Select <b>Single Frequency</b> to transmit the transducer beams at a frequency set to your preference. To change the frequency, see <i>Low/Medium/High Frequency</i>.</p>
<b>Beam Select</b>	If the selected sonar source includes more than one beam, you can select which beams will be displayed in the sonar view.
<b>Low/Medium/High Frequency</b>	The control head will automatically select a frequency for each transducer beam. Use the Frequency Menus to adjust each frequency higher or lower. Transmit Mode must be set to Single Frequency to access these menus.
<b>Low/Medium/High Frequency Spectrum</b>	For each sweep range, set the start frequency and the end frequency. Transmit Mode must be set to Spectrum Sweep to access these menus.
<b>Noise Filter</b>	Use Noise Filter to limit interference on the sonar view from sources such as your boat engine, turbulence, or other sonar devices.

**CONTACT HUMMINBIRD**

---

<b>Web site</b>	humminbird.com
<b>E-mail</b>	service@humminbird.com
<b>Telephone</b>	1-800-633-1468
<b>Direct Shipping</b>	Humminbird Service Department 678 Humminbird Lane Eufaula, AL 36027 USA

 **WARNING!** This device should not be used as a navigational aid to prevent collision, grounding, boat damage, or personal injury. When the boat is moving, water depth may change too quickly to allow time for you to react. Always operate the boat at very slow speeds if you suspect shallow water or submerged objects.

 **WARNING!** Disassembly and repair of this electronic unit should only be performed by authorized service personnel. Any modification of the serial number or attempt to repair the original equipment or accessories by unauthorized individuals will void the warranty.

**Environmental Compliance Statement:** It is the intention of Johnson Outdoors Marine Electronics, Inc. to be a responsible corporate citizen, operating in compliance with known and applicable environmental regulations, and a good neighbor in the communities where we make or sell our products.

**WEEE Directive:** EU Directive 2002/96/EC “Waste of Electrical and Electronic Equipment Directive [WEEE]” impacts most distributors, sellers, and manufacturers of consumer electronics in the European Union. The WEEE Directive requires the producer of consumer electronics to take responsibility for the management of waste from their products to achieve environmentally responsible disposal during the product life cycle.

WEEE compliance may not be required in your location for electrical & electronic equipment [EEE], nor may it be required for EEE designed and intended as fixed or temporary installation in transportation vehicles such as automobiles, aircraft, and boats. In some European Union member states, these vehicles are considered outside of the scope of the Directive, and EEE for those applications can be considered excluded from the WEEE Directive requirement.



This symbol [WEEE wheelie bin] on product indicates the product must not be disposed of with other household refuse. It must be disposed of and collected for recycling and recovery of waste EEE. Johnson Outdoors Marine Electronics, Inc. will mark all EEE products in accordance with the WEEE Directive. It is our goal to comply in the collection, treatment, recovery, and environmentally sound disposal of those products; however, these requirements do vary within European Union member states. For more information about where you should dispose of your waste equipment for recycling and recovery and/or your European Union member state requirements, please contact your dealer or distributor from which your product was purchased.

Airmar is a registered trademark of Airmar Technology Corp.

Down Imaging, Humminbird, ION, MEGA Imaging, ONIX, Side Imaging, and SOLIX are trademarked by or registered trademarks of Johnson Outdoors Marine Electronics, Inc.