

# DEPTH SOUNDER



# OPERATIONS MANUAL

# HUMMINBIRD

## TRANSDUCER MOUNTING PROCEDURE

Humminbird's high-speed transducer is supplied with your LCR. This transducer has been designed to give good high speed readings on most all boat designs, including aluminum.

Please carefully consider the following before installing your transducer.

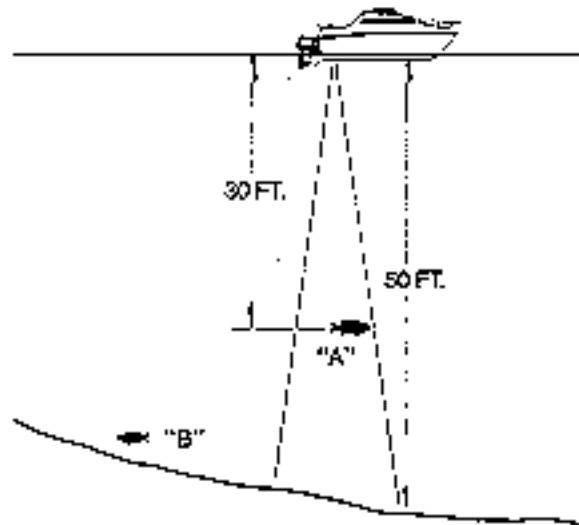
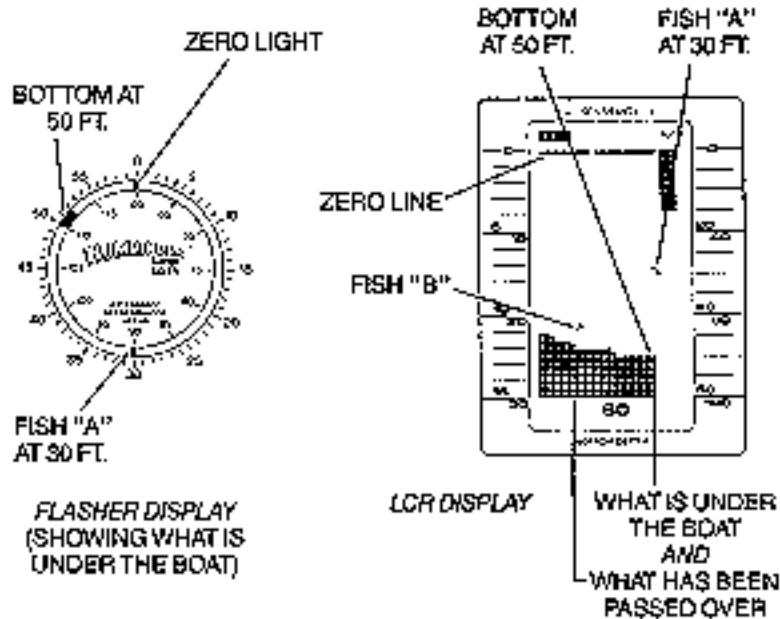

FIGURE 1

## TRANSDUCER MOUNTING OPTIONS

- A. Transom Mount- The Humminbird high speed transducer allows the transducer element to be mounted below the bottom of the boat hull keeping the transducer out of turbulent water and insuring good high speed operation. The transducer will absorb the blow of any obstruction

by rotating up out of the metal spring bracket without harming the transducer, or your boat. The transducer can be re-engaged by simply rotating the transducer down and snapping it back in place. (See Figure A)

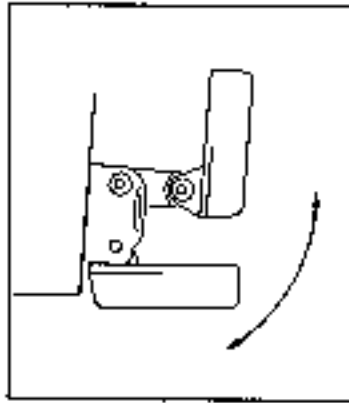

Figure A

- B. Inside Hull Mount- The high speed transducer can be mounted inside the hull (without pivot assembly) using the proper two-part epoxy, such as Humminbird's epoxy kit. Even though there is some loss of signal in shooting through the hull, your LCR will perform well with this type of installation. You cannot shoot through the hull of an aluminum boat.
- C. Trolling motor Mount- This type of transducer is not supplied with your LCR. It is designed to mount on the foot of a trolling motor. You may exchange your un-used high speed transducer for a trolling motor transducer. Call the Humminbird Customer Service Department.
- D. Bronz Thru-Hull Mount- This transducer is not supplied with your LCR but for an additional cost you may exchange your un-used high speed transducer for a bronz thru-hull. The bronz thru-hull transducer has a threaded stem which installs through a hole drilled in the boat hull, leaving the housing exposed under the boat. This type of installation must be used for many boats with in-board engines, because there is no suitable location on the transom away from the noise and turbulence created by the prop. A bronz thru-hull transducer should be installed by qualified personnel only.  
The LCR will operate well at high speeds with a properly mounted transducer. Remember, a transducer will not work transmitting through air or through air bubbles.

## 1. TRANSOM MOUNTING PROCEDURE

### Step 1.

**MOUNTING LOCATION-** It is important that the transducer be mounted on the transom where water flow is in constant contact with the transducer. You may wish to observe the rear of the boat while it is moving through the water to determine the best mounting location.

### Step 2.

**BRACKET INSTALLATION (Aluminum Boats)-** To install the metal bracket on an aluminum boat locate the template on the transom between rows of rivets, or ribs that are on the bottom of the boat. Align the template so that the bottom corner of the template nearest the center of the transom is on the bottom edge of the transom.

Figure B

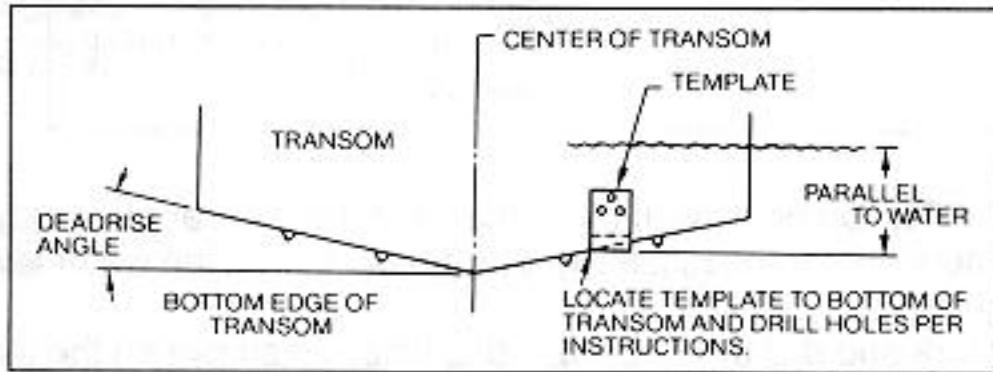

Once the location is determined mark and drill three 7/64" dia.. holes noted on the template. Attach the metal bracket using three #10 self threading screws supplied. Be sure to align holes in the center of the Bracket slots. On some aluminum boats it may be necessary to use a wood back-up plate. It is important to use a silicone sealant between the screwhead and bracket in order to prevent leaking. (See Figure C)

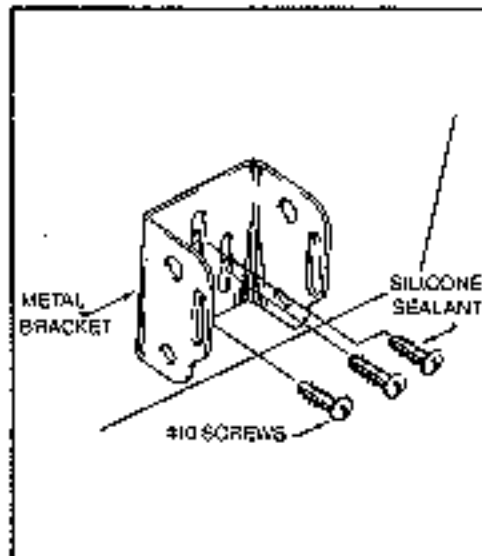
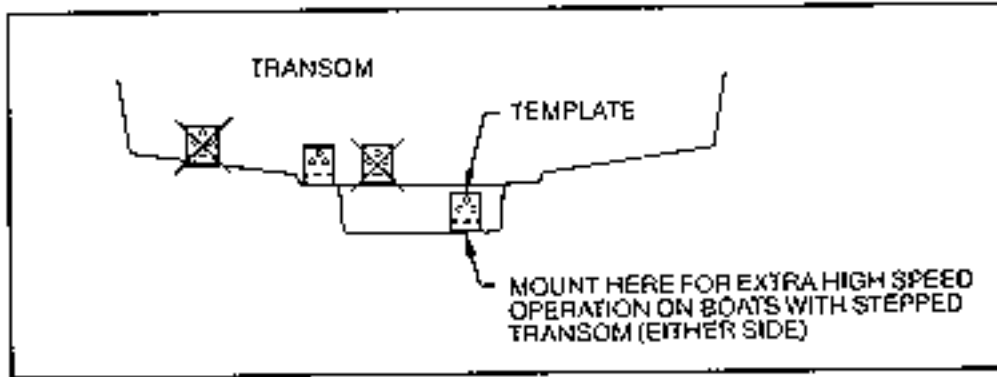

Figure C

Step 2.  
BRACKET INSTALLATION (Fiberglass Boats)- If your boat has a stepped transom located below and under the main transom, the compact transducer design allows mounting in this area. This mounting location is recommended for good reading at very high speeds. (See Figure D)

To install the metal bracket on a fiberglass boat, locate the template on the transom in the same manner as for an aluminum boat. (See Figure C)

Figure D



NOTE: On boats with more than 15 degree deadrise angle it may be necessary to mount the transducer slightly off parallel with the water level. (See Figure E)

Mark and drill the three 9/64" dia. holes as shown on the template. Attach the metal bracket using the three #10 self threading screws supplied. Be sure to align the holes so that they are centered vertically in the three slots found in the bracket. It is important to use a silicone sealant between the screwhead and bracket in order to prevent leaking.

Figure E

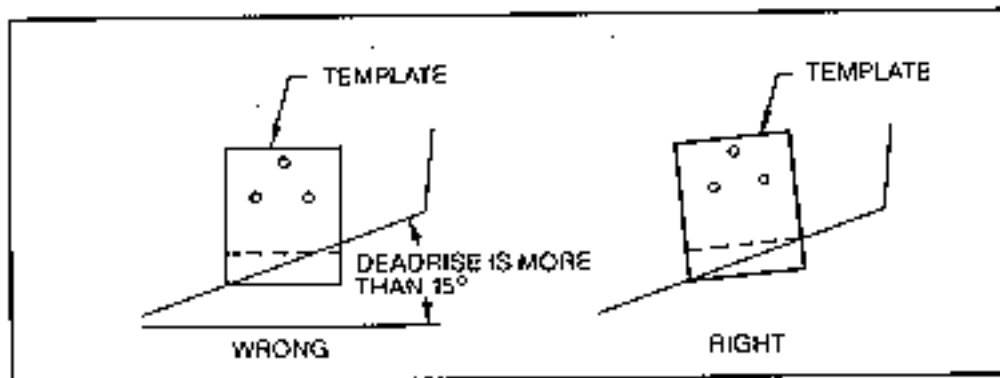

Step 3.

TRANSDUCER PIVOT ASSEMBLY- Assemble the pivot to the transducer main body using the two 1/4"x5/8" allen head screws, two 3/8" tooth washers and two, 1/4" square nuts. Make sure the tooth washers are sandwiched between the transducer main body and the pivot. The square nuts are trapped inside the pivot and will not rotate as the allen head screws are tightened. HOWEVER, DO NOT TIGHTEN AT THIS POINT. (See Figure F)

**CAUTION: DO NOT APPLY LOCTITE® OR SIMILAR LOCKING COMPOUNDS BECAUSE THEY WILL ATTACK THE PLASTIC.**

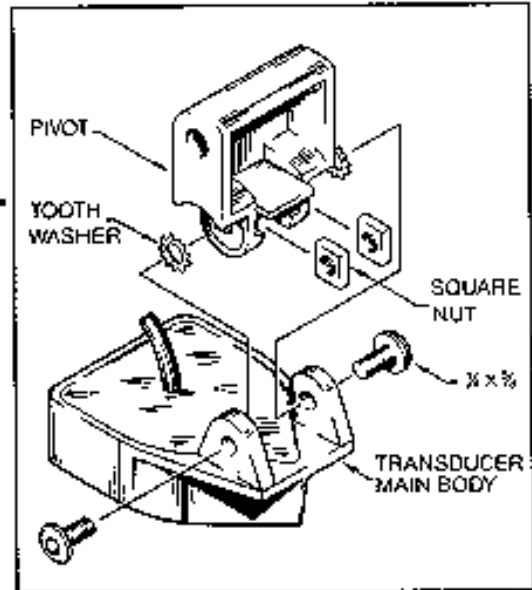

Figure F

Step 4

TRANSDUCER ASSEMBLY- Insert the transducer assembly into the metal bracket from the bottom. Push up until the holes in the plastic pivot align with the uppermost holes in the bracket. Slide the O-ring on to the headed pin and insert it through the two parts. Assemble by screwing the 1/4"x3/8" allen head screw into the end of the pin and tighten. (See Figure G)

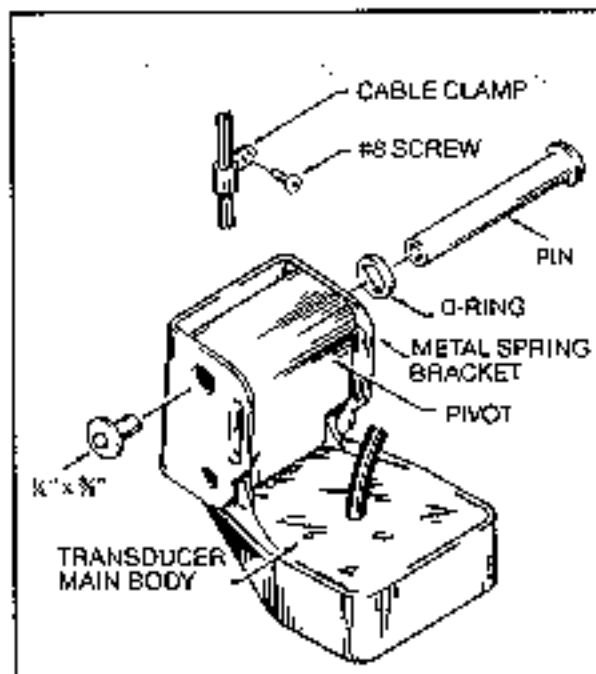

Figure G

Step 5

ANGLE ALLIGHMENT- Set the transducer angle so that it is parallel with the bottom of the boat hull. Once proper alignment is achieved, tighten the two allen head screws using the 5/32" allen

wrench provided. The screws are visible through the access holes on each side of the metal bracket. Check to make sure the transducer main body is rigidly fastened to the pivot. (See Figure H)

Figure H

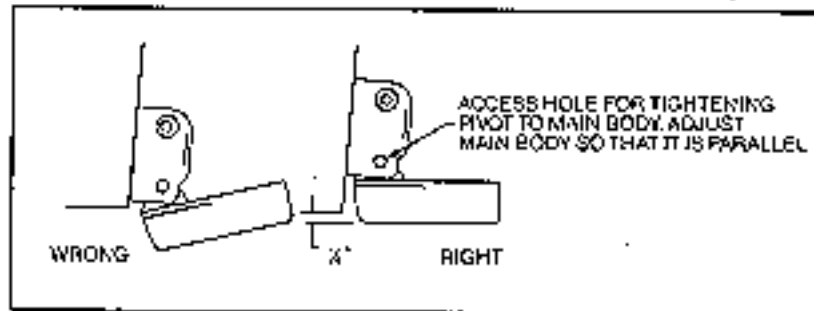

#### Step 6

**CHECK POSITION OF TRANSDUCER-** At this point, check to see that the bottom of the transducer is a minimum of  $\frac{1}{4}$ " below the bottom of the transom. (However, as noted in STEP 2, the top of the transducer cannot fall below the bottom of the transom). If it is not, remove the transducer assembly from the metal bracket by removing the pin installed during STEP 3. Loosen the metal bracket mounting screws, re-position the bracket utilizing its slotted holes, tighten and re-assemble. It may be necessary to replace the silicone sealant after this adjustment is made.

**NOTE:** It may be necessary to make several high speed runs to adjust transducer either UP/DOWN or to re-adjust the angle to achieve optimum results.

#### Step 7

**CABLE CLAMPS-** Install cable clamps as necessary by drilling a  $\frac{1}{8}$ " dia. hole for the # 8 screw supplied.

## 2. INSIDE HULL MOUNTING PROCEDURE

**Warning:** In order to achieve proper results with this type installation, it is important that the transducer be mounted by someone familiar with the use of two part epoxy adhesives. For this reason, Techsonic Industries, Inc. will not be responsible for any damage due to the mounting of your transducer in this manner.

**NOTE:** An Epoxy Kit (Part N. EPK) is available from Humminbird. This Epoxy Kit has been formulated for Inside Hull Transducer Installation.

1. Select as flat an area as possible near the aft end and center of boat where the hull is thin and not double. If the bottom has a runner down the center of boat, select an area to one side of the runner, but as close to the runner as possible.
2. Clean the inside of the boat with lacquer thinner in the area transducer is to be mounted. Outside of boat in this area should also be cleaned. (Not with lacquer thinner).
3. Put approximately one inch of water in the bottom of the boat.
4. Put transducer in the water. The bottom of the transducer should be in a flat area and should be in good contact with the bottom of the boat.
5. Operate the LCR with the boat operating at high speed. The transducer may have to be moved in order to find an area where satisfactory operation is observed.
6. When an area is found that produces satisfactory operation, mark the location of the transducer.

7. Remove the water and transducer and clean the marked area and the bottom of the transducer thoroughly.
8. Using the Humminbird Epoxy Kit or equivalent, mix an ample amount of epoxy without causing it to bubble and pour it in the area the transducer is to be mounted. The puddle should be larger than the bottom of the transducer.
9. Coat the bottom of the transducer with epoxy, then put it in the center of the puddle and push down on the transducer while moving it around in a circular motion. This forces out any air bubbles that may be trapped between the bottom of the transducer and the hull of the boat.
10. Let epoxy cure then the transducer is ready to operate. No water is now required in the bottom of the boat and gas and oil that is spilled inside of the boat will not degrade performance as it will if the transducer is placed only in water.  
CAUTION: Do not use the silicone seal or any soft adhesive to bond the transducer to the hull. This will reduce the sensitivity of the unit.

#### CAUTIONS

1. Occasionally the "eye" of your transducer may become dirty from storage or from contact with oils present in boats or marina environments. (Oil will cause the "eye" to lose the intimate contact with the water which is necessary for efficient operation.) The "eye" may be cleaned with liquid detergent.
2. Improper installation of the transducer can alter the efficiency and accuracy of the entire system.
3. If your boat or transducer is out of the water for a period of time, it may take a short period of time for the transducer to become thoroughly "wetted" when returned to the water. Also, re-entry may cause turbulence, which will create air bubbles in the "eye" of the transducer. The bubbles will disappear in a short time or can be removed by rubbing the transducer "eye" with your fingers while the transducer is in the water.
4. If your instrument should fail to function, be sure to check all the electrical connections before removing the transducer or calling a serviceman.
5. Inspect your transducer cable and make sure that it has not been cut or damaged to the point where it will affect the performance of the transducer. A slight nick or cut, exposing the outer cable, can be repaired by wrapping with electrical tape. A transducer can be damaged if the inner cable and outer cable are allowed to make contact. Such a problem can sometimes be corrected by properly splicing the coaxial cable. This should only be attempted by a qualified service technician.
6. If your LCR is not working properly and you suspect the problem might be in your transducer, we would recommend you borrow a unit from a friend and try it on your boat. If the symptoms are the same, you can almost be certain that the problem is in the transducer.

#### INSTALLING THE LCR

The LCR should be mounted on a flat, solid surface for maximum stability. The low profile swivel mount has four holes drilled in the base. It is recommended that all four holes be used.

Position the swivel base and drill four 1/4" diameter holes. Note: The LCR hole pattern is the same as for all Humminbird flasher units. Use hardware provided to mount this base to the boat.

Next place the gimbal bracket on the swivel base and attach with four small machine screws, provided.

Place the LCR in the gimbal mount and make certain the rubber washers provided are placed between the unit and the gimbal bracket. Important: Note which side of the gimbal faces forward. (Slots on gimbal bracket go towards rear). Also, rubber washer must be located between the unit and the gimbal bracket.



Install the mounting knobs and tighten snugly. The unit can now be swiveled and tilted to any desired position.

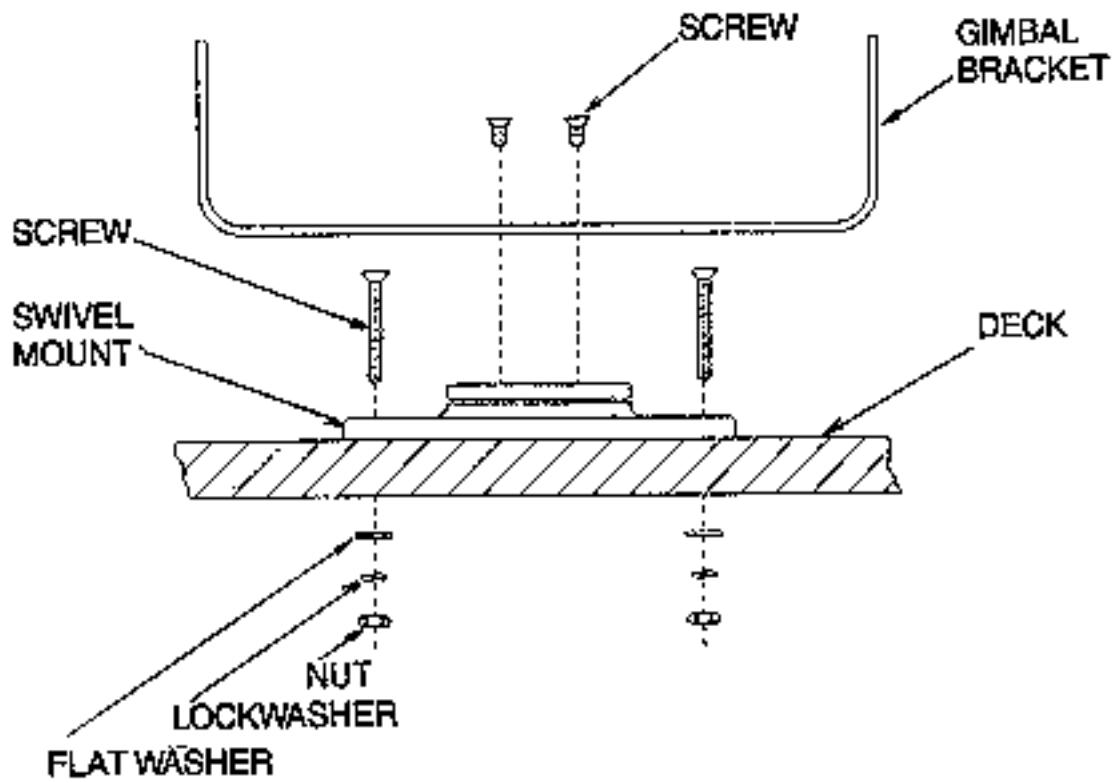
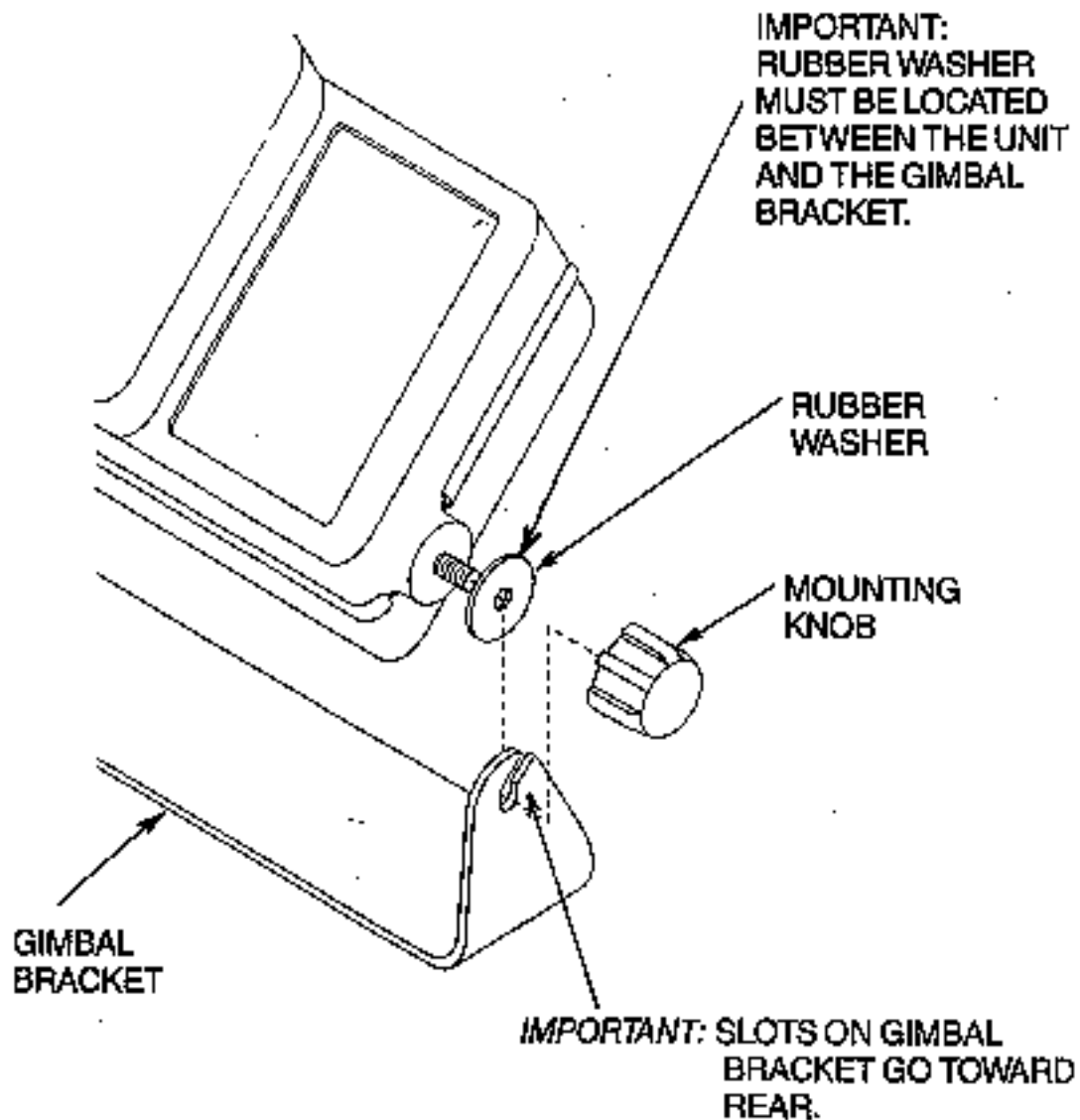

FIGURE 9



**FIGURE 10**

#### OTHER MOUNTING OPTIONS

1. The LCR gimbal bracket can also be mounted on the SM-4, quick disconnect swivel mount.
2. The LCR gimbal bracket can also be mounted directly to the dash without the swivel mount, however, this method is not recommended since the unit cannot be rotated.

#### INSTALLING THE CABLES

Your LCR comes equipped with Humminbird's new Angle-Lock power and transducer connectors. The power connector is identified with the letter P on the back of the plug.

It plugs into the outlet on the back of the unit marked "Power". The transducer connector is identified with the letter T and plugs into the outlet on the back of the unit marked "Transducer". Note: An adapter (AD-4) is available to allow use of an old waterproof (BNC) transducer with the LCR, but be sure that the transducer is a 16-degree. A 32-degree transducer cannot be used. A 1 1/8" hole must be drilled to pull through the transducer connector. After drilling the hole, pull the transducer connector up through the hole. If you are installing two units, both transducer connectors can be pulled through this 1 1/8" inch hole. Next, push the power cable wires down through the hole. A hole cover has been provided which will dress and hold the wires. Install the hole cover after determining the necessary wire length from the hole. The power cable has a red lead to the positive (+) post and the black lead to the negative (-) post. Install a 1 amp fuse between the red cable and positive post of your 12-volt battery. If a fuse panel is available, we recommend wiring the power cable into the fuse panel. Note: The LCR must be fused separately from any other accessory. Your Angle-Lock connectors can only be plugged in one way. Position the connector so the letter P or T can be read and the 90 degree bend is pointed downward. Push the connector in as far as it will go. Turn the positive locking ring as far as it will go clockwise until you feel it lock. Locking ring as far as it will go clockwise until you feel it lock. Your connector is now locked into place. Note: For easy access to the connectors, simply loosen the mounting knobs and tilt your LCR forward. The connectors are now in full view and easy to plug or unplug.

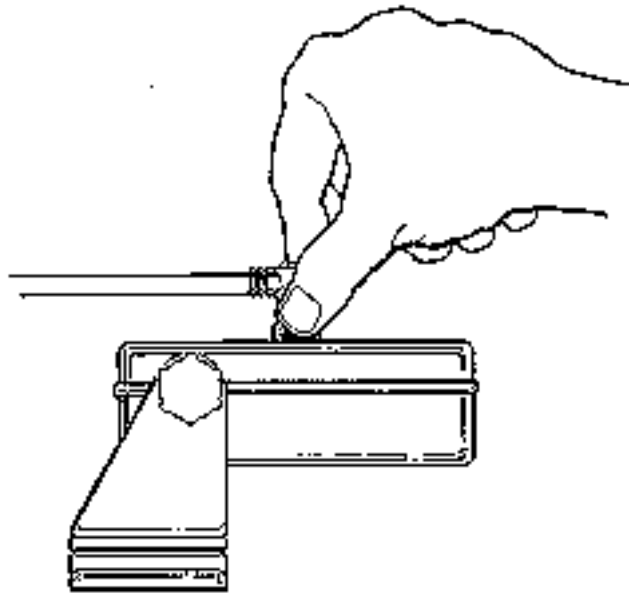

**WARNING:** This device should not be used as a navigation aid to prevent collision, grounding, boat damage or personal injury. When the boat is moving, submerged objects will not be seen until they are already under the boat or bottom depths may change too quickly to allow time for the boat operator to react. Always operate the boat at very slow speeds if you suspect shallow water or submerged objects.

"MADE BETTER TO WORK BETTER"

This manual covers the installation and operation of your Humminbird Depth Sounder.

Techsonic Industries, Inc. One Humminbird Lane Lake Eufaula, AL 36027

"WE'RE CHANGING THE WAY YOU FISH"

## INTRODUCTION

Congratulations! You have just purchased the finest depth sounder on the market. Your Humminbird has been engineered and built to meet the rugged standards of today's discriminating fishermen. In addition to telling you how deep the water is, your Humminbird will also reveal underwater structure, as well as fish.

## IMPORTANT

Save the box your Humminbird came in. In the event you should need to return it to our plant, you should use this as your shipping carton.

## WARNING

Please read this instruction manual thoroughly before attempting to operate your Humminbird. Failure to follow proper operation or installation procedures could nullify your warranty.

**NOTE:** Please complete and mail warranty card immediately after purchase.

Good luck and good fishing from your friends at Techsonic.

## HUMMINBIRD FEATURES

("Or why your 'Bird outperforms all other brands.")

**Gold Plated Contacts** - Gold is one of the best conductors of electricity known, and unlike other metals, it will not corrode. This is why our waterproof flasher units are equipped with gold plated contact points on both the transducer and power cable connectors.

**Completely Waterproof-Tough** inner and outer ABS material cases house all flasher units. Sealed with watertight "O" rings so that rain, humidity, spray (including salt water) or condensation will not affect your Humminbird.

**Epoxy Based Printed Circuit Boards** - We use a tough epoxy filled fiberglass printed circuit board, built to military specifications. Unlike paper based boards, the epoxy based board will not crack or break, and will stand up to long term use in rough water.

Positive Noise Reject System - Easily adjustable control knob to eliminate interference and false signals with the Humminbird positive noise reject system.

High Speed Readings - Clear bottom readings at any speed up to 75 miles per hour can be achieved providing the transducer has been properly installed.

Super-Bright Thin Line Lamp-Even in bright sunlight, the flasher super-bright thin line lamp gives detailed readings.

Night Light- Humminbird's patented night light makes for easy night readings. There is no additional power drain because the digits adjacent to the flash are lighted by the flash itself.

#### Other Features

Crystal Control Oscillators for better performance and reliability.

Solid State Electronic Circuitry. Microcomputer Controlled. Heavy Duty Motor for better performance and longer life. Lifetime-Guaranteed Service Policy with three day turnaround and a one year full warranty.

Transducers- Humminbird builds all our own transducers. The revolutionary new design means better performance, finer quality and instant pickup. These transducers never require sanding.

## THEORY OF OPERATION

Your depth sounder works on the sonar principle. The control head generates an electronic signal which is coupled to the transducer where it is changed to an ultrasonic signal. This signal travels through the water until it hits an object or the lake bottom. The signal is then reflected back to the transducer, where it is changed back to an electronic signal.

The control head measures the amount of time it takes the signal to travel from the transducer to the reflecting object and back again. This time is then converted into feet (since the signal travels at a constant speed - approximately 4800 feet per second), and the number of feet to the object is indicated on the calibrated dial with the spinning lamp. The lamp revolves around the dial once for each 120 foot reading on the 120 foot units and once for each 60 foot reading on the 60 foot units. Therefore, the motor in the 120 foot unit rotates at 1200 rpm and in the 60 foot unit 2400 rpm. The motor in the Super Thirty II unit also travels at the speed of 2400 rpm. This is accomplished by the use of an integrated circuit signal processor which permits a 30 foot readout to be displayed on a unit running at the speed of a 60 foot model.

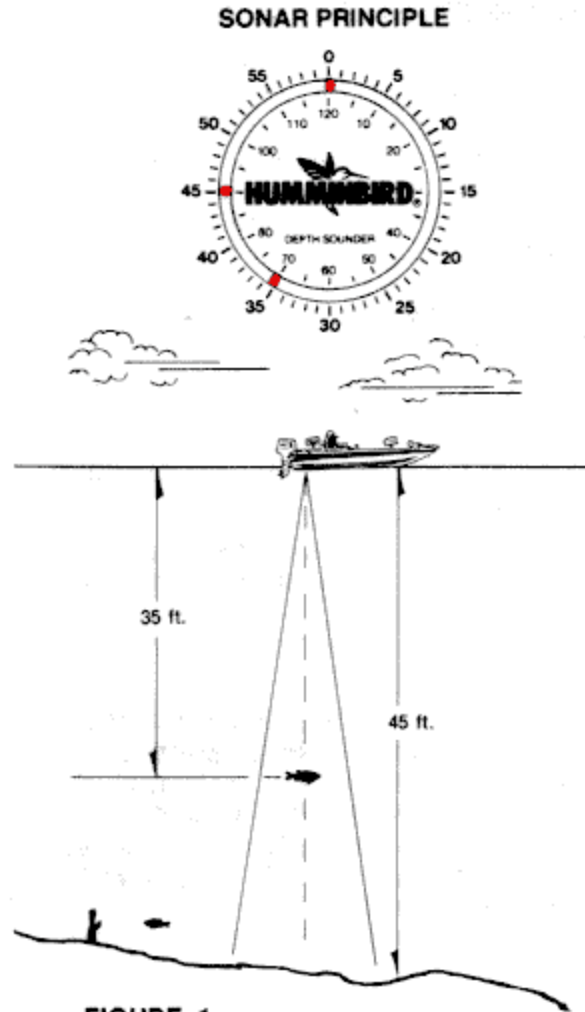

## YOUR TRANSDUCER

The transducer is the transmit/receive "antenna" of your depth sounder. The transducer converts an electrical signal from your instrument into acoustical energy which is then transmitted through the "eye" of the transducer into the water. The return signal (echo) excites the "eye" with an acoustical shock wave and causes the transducer to send an electrical signal back to your instrument. The "eye" of the transducer is the flat portion that is focused downward into the water. For maximum efficiency the transducer's "eye" must not be obstructed and it must be in intimate contact with the water ("wetted").

It is suggested you keep the face of the transducer clean. This can be done with soap and water.

NOTE: In order for your Humminbird to perform at its maximum potential, care should be taken to install the transducer properly. This is the most critical part of the Humminbird installation. Please read the following sections thoroughly and follow the installation instructions carefully.

## TRANSDUCER MOUNTING OPTIONS

A. Transom Mount - The Humminbird high speed transducer allows the transducer element to be mounted below the bottom of the boat hull keeping the transducer out of turbulent water and insuring good high speed operation. The transducer will absorb the blow of any obstruction by rotating up out of the metal spring bracket without harming the transducer, or your boat. The transducer can be re-engaged by simply rotating the transducer down and snapping it back in place.

**FIGURE 2**

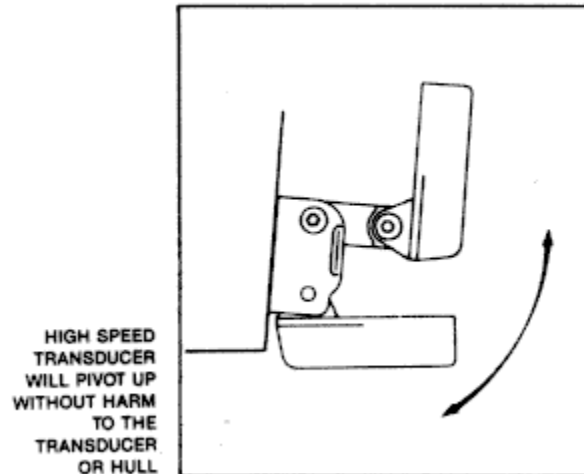

B. Inside Hull Mount - The high speed transducer can be mounted inside the hull (without pivot assembly) using the proper two-part epoxy, such as Humminbird's epoxy kit. It is important to carefully follow the mounting procedure in this manual to insure that a proper mounting location is selected. Improper mounting will result in loss of depth sounder signal. Do not shoot through the hull of an aluminum boat.

C. Trolling Motor Mount - This type of transducer is not supplied with your unit. It is designed to mount on the foot of a trolling motor. You may exchange your un-used high speed transducer for a trolling motor transducer. Call the Humminbird Customer Service Department.

D. Bronze Thru-Hull Mount - This transducer is not supplied with your unit but for an additional cost you may exchange your un-used high speed transducer for a bronze thru-hull. The bronze thru-hull transducer has a threaded stem which installs through a hole drilled in the boat hull, leaving the housing exposed under the boat. This type of installation must be used for many boats with inboard engines, because there is no suitable location on the transom away from noise and turbulence created by the prop. A bronze thru-hull transducer should be

installed by qualified personnel only. E. Transducer Exchange - You may exchange your un-used transducer for another type, however, some exchanges may require an additional charge. Please call the Humminbird Customer Service Department TOLL FREE number listed in the front of the manual. Your unit will operate well at high speeds with a properly mounted transducer. Remember, a transducer will not work transmitting through air or air bubbles.

#### CAUTIONS

1. Occasionally the "eye" of your transducer may become dirty from storage or from contact with oils present in boats or marina environments. (Oil will cause the "eye" to lose the intimate contact with the water which is necessary for efficient operation.) The "eye" may be cleaned with liquid detergent.

2. Improper installation of the transducer can alter the efficiency and accuracy of the entire system.
3. If your boat or transducer is out of the water for a period of time, it may take a short period of time for the transducer to become thoroughly "wetted" when returned to the water. Also, re-entry may cause the turbulence which will create air bubbles on the "eye" of the transducer. The bubbles will disappear in a short time or can be removed by rubbing the transducer "eye" with your fingers while the transducer is in the water.
4. If your instrument should fail to function, be sure to check all the electrical connections before removing the transducer or calling a serviceman.
5. Inspect your transducer cable and make sure that it has not been cut or damaged to the point where it will affect the performance of the transducer. A slight nick or cut, exposing the outer cable, can be repaired by wrapping with electrical tape. A transducer can be damaged if the inner cable and outer cable are allowed to make contact. Such a problem can sometimes be corrected by properly splicing the coaxial cable. This should only be attempted by a qualified service technician.
6. If your unit is not working properly and you suspect the problem might be in your transducer, we would recommend you borrow a unit from a friend and try it on your boat. If the symptoms are the same, you can almost be assured that the problem is in the transducer.

## TRANSOM MOUNTING PROCEDURE

### Step 1

**MOUNTING LOCATION** - It is important that the transducer be mounted on the transom where water flow is in constant contact with the transducer. You may wish to observe the rear of the boat while it is moving through the water to determine the best mounting location.

### Step 2 (Aluminum Boats)

**BRACKET INSTALLATION** To install the metal bracket on an aluminum boat locate the template on the transom between rows of rivets, or ribs that are on the bottom of the boat. **NOTE:** Template is on the last page of the manual. Align the template so that the bottom corner of the template nearest the center of the transom is on the bottom edge of the transom. (See figure 3.)

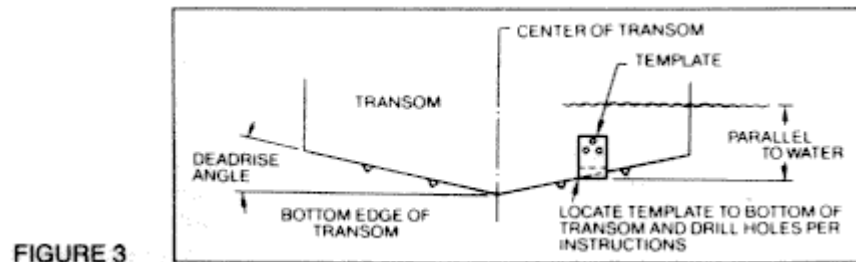

**FIGURE 3**

Once the location is determined mark and drill three 7/64" dia holes noted on the template. Attach the metal bracket using three #10 self threading screws supplied. Be sure to align holes in the center of the bracket slots. On some aluminum boats it may be necessary to use a wood back-up plate. It is important to use a silicone sealant between the screwhead and bracket in order to prevent leaking. (See Figure 4).



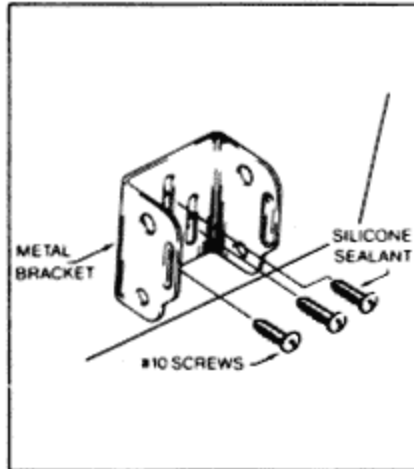
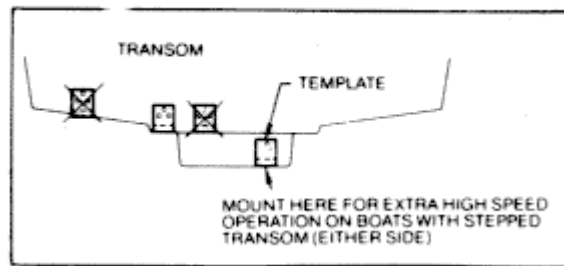

FIGURE 4

Step 2 (Fiberglass Boats) BRACKET INSTALLATION - If your boat has a stepped transom located below and under the main transom, the compact transducer design allows mounting in this area. This mounting location is recommended for good reading at very high speeds. (See Figure 5).

FIGURE 5



To install the metal bracket on a fiberglass boat, locate the template on the transom in the same manner as for an aluminum boat. (See figure 4). NOTE: On boats with more than 15° deadrise angle it may be necessary to mount the transducer slightly off parallel with the water level. (See Figure 6).

FIGURE 6

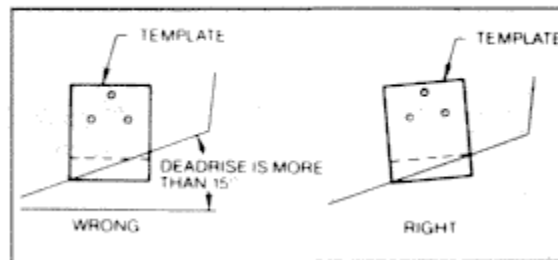

Mark and drill the three 9/6," dia holes as shown on the template. Attach the metal bracket using the three #10 self threading screws supplied. Be sure to align the holes so that they are centered vertically in the three slots found in the bracket. It is important to use a silicone sealant between the screwhead and bracket in order to prevent leaking.

Step 3

**TRANSDUCER PIVOT ASSEMBLY** Assemble the pivot to the transducer main body using the two 1/4"x%" alien head screws, two %," tooth washers and two 1/2," square nuts. Make sure the tooth washers are sandwiched between the transducer main body and the pivot. (See Figure 7). The square nuts are trapped inside the pivot and will not rotate as the alien head screws are tightened. **HOWEVER, DO NOT TIGHTEN AT THIS POINT** (See Figure 7).

**CAUTION: DO NOT APPLY LOCTITE® OR SIMILAR LOCKING COMPOUNDS BECAUSE THEY WILL ATTACK THE PLASTIC.**

**FIGURE 7**

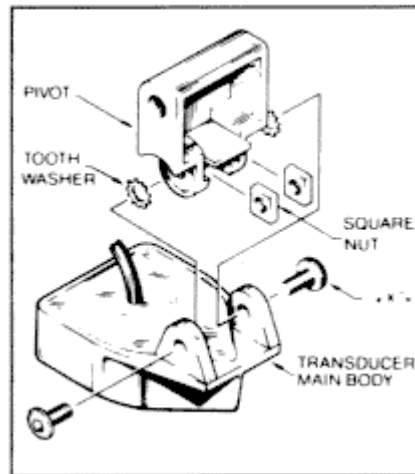

**Step 4**

**TRANSDUCER ASSEMBLY** -Insert the transducer assembly into the metal bracket from the bottom. Push up until the holes in the plastic pivot align with the uppermost holes in the bracket. (See Figure 8). Slide the O-ring on to the headed pin and insert it through the two parts. Assemble by screwing the 1/4"x%" alien head screw into the head of the pin and tighten.

**Step 5**

**ANGLE ALIGNMENT** - Set the transducer angle so that it is parallel with the bottom of the boat hull. (See figure 9). Once proper alignment is achieved, tighten the two alien head screws using the %2" alien wrench provided. The screws are visible through the access holes on each side of the metal bracket. Check to be sure the transducer main body is rigidly fastened to the pivot.

**Step 6**

**CHECK POSITION OF TRANSDUCER** At this point, check to see that the bottom of the transducer is a minimum of %," below the bottom of the transom.

(However, as noted in STEP 2, the top of the transducer cannot fall below the bottom of the transom). If it is not, remove the transducer assembly from the metal bracket by removing the pin installed during STEP 3. (See Figure 8). Loosen the metal bracket mounting screws, reposition the bracket utilizing its slotted holes, tighten and reassemble. It may be necessary to replace the silicone sealant after this adjustment is made.

**FIGURE 9**

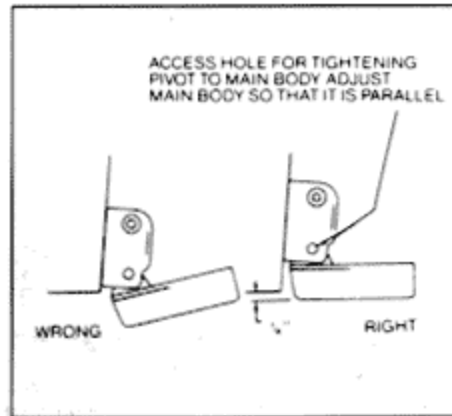

NOTE: It may be necessary to make several high speed runs to adjust transducer either UP/DOWN or to readjust the angle to achieve optimum results.

Step 7 CABLE CLAMPS - Install cable clamps as necessary by drilling a  $\frac{1}{8}$ " dia. hole for the #8 screw supplied. Be sure to route the cable to the side of the bracket. The cable can be cut if it is installed in the center of the bracket. (See Figure 10). FIGURE 10

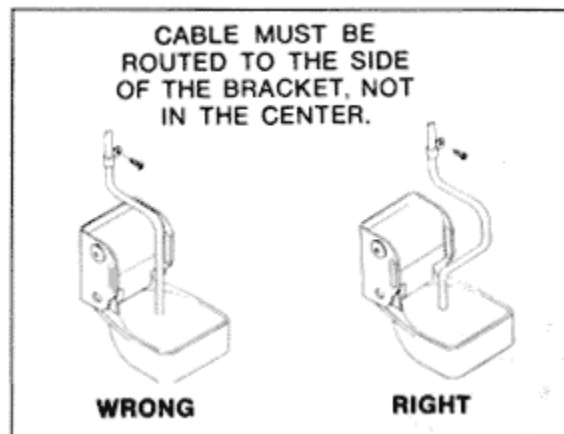

### 3. INSIDE HULL MOUNTING PROCEDURE

Warning: In order to achieve proper results with this type installation, it is important that the transducer be mounted by someone familiar with the use of two part epoxy adhesives. For this reason, Techsonic Industries, Inc. will not be responsible for any damage due to the mounting of your transducer in this manner.

IMPORTANT: Be sure to follow steps 3 through 6 to insure that a proper mounting location is found. Do not epoxy the transducer until this is done. It may not be possible to find a good mounting location on some boat hulls due to their construction.

1. Select as flat an area as possible near the aft end and center of boat where the hull is thin and not double. If the bottom has a runner down the center of boat, select an area to one side of the runner, but as close to the runner as possible.
2. Clean the inside of the boat with lacquer thinner in the area transducer is to be mounted. Outside of boat in this area should also be cleaned. (Not with lacquer thinner.)

3. Put approximately one inch of water in the bottom of the boat.
4. Put transducer in the water. The bottom of the transducer should be in a flat area and should be in good contact with the bottom of the boat.
5. Operate the unit with the boat operating at high speed. The transducer may have to be moved in order to find an area where satisfactory operation is observed.
6. When an area is found that produces satisfactory operation, mark the location of the transducer.
7. Remove the water and transducer and clean the marked area and the bottom of the transducer thoroughly.
8. Using the Humminbird Epoxy Kit mix an ample amount of epoxy without causing it to bubble and pour it in the area the transducer is to be mounted. The puddle should be larger than the bottom of the transducer.
9. Coat the bottom of the transducer with epoxy, then put in the center of the puddle and push down on transducer while moving it around in a circular motion. This forces out any air bubbles that may be trapped between the bottom of the transducer and the hull of the boat.
10. Let epoxy cure then the transducer is ready to operate. No water is now required in the bottom of the boat and gas and oil that is spilled inside of the boat will not degrade performance as it will if the transducer is placed only in water. Caution: Do not use silicone seal or any soft adhesive to bond the transducer to the hull. This will reduce the sensitivity of the unit.

### 3. TROLLING MOTOR MOUNTING PROCEDURE

A "Trolling Motor Transducer," is designed to be mounted on the foot of the trolling motor with the aid of an adjustable clamp, included standard (see below). Your trolling motor transducer will give an excellent reading with no interference from the electric motor. Some boat manufacturers are now glassing in a second transducer beneath the front deck for thru the hull reading of the forward mounted depth sounder. This installation also serves a dual purpose in that a fisherman can run his big motor at idle speed and use his front depth sounder to scan for submerged stumps or obstacles. Such a practice can often prevent damage to props and lower units of the big outboard.

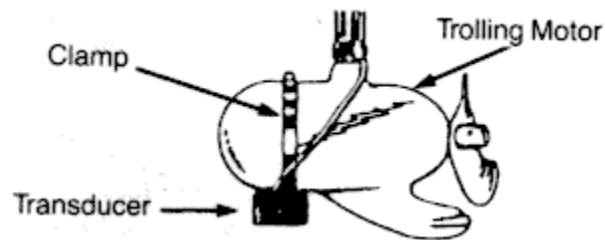

### MATCHING THE PROPER TRANSDUCER

A 2" diameter transducer is used on all Humminbird flasher units, except the Super Thirty II which uses a 1" diameter transducer.

The 2" transducer emits a 16 degree cone angle which, we feel, is most efficient for medium to deep range flasher units. It concentrates the signal on a given target for a better medium to deep return, thus a better display on the flasher dial.

The 1" transducer used on the Super Thirty II emits a 32 degree cone angle. This wider beam is used in shallow water since it provides a wider area of coverage.

NOTE: While the 1" transducer is recommended for the Super 3011, some may prefer the performance of the 2" transducer. Either will work and it may be a matter of personal preference as to which one is used.

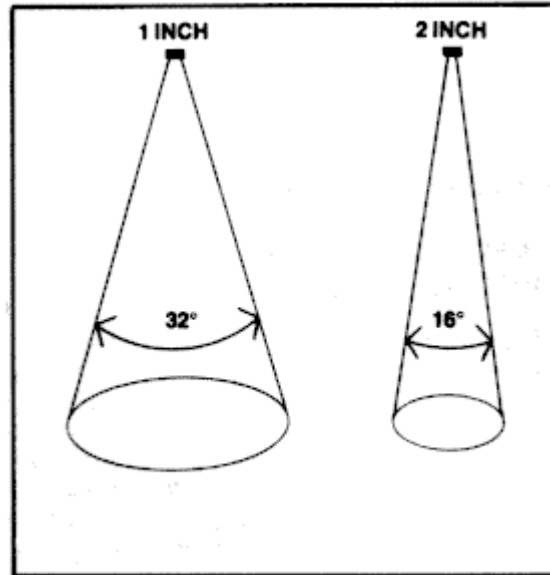

#### TRANSDUCER SWITCH ASSEMBLIES FOR MODELS TS1-3 AND TS2-3

The Transducer Switch Model TS1-3 comes complete with one switch and one extension cable. This switch allows you to use one Humminbird depth sounder with two transducers and is ideal when using one transducer mounted on the transom and the other transducer mounted on your trolling motor.

The transducer switch model TS2-3 comes complete with one switch and two extension cables. This switch allows you to use two Humminbird Depth Sounders with a single transducer, mounted anywhere feasible for your application.

NOTE: With switch in this position depth sounder operates from Transducer #2.

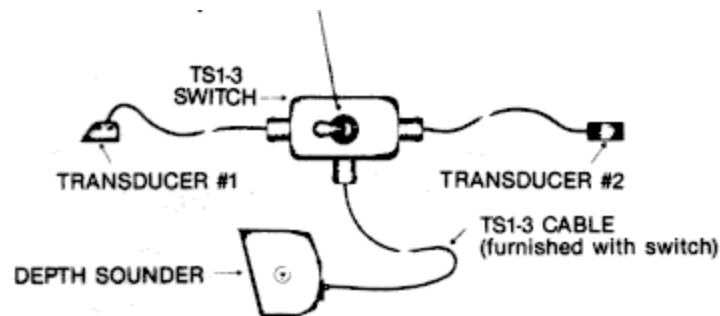

We recommend the use of our new Swivel Mount SM-4 (not shown) in conjunction with our TS1-3.

Mounting Instructions: Drill a 1/8" hole in the desired location and mount switch with extra nut and washer provided. See illustrations below for correct cable connections.

NOTE: With switch in this position depth sounder #2 operates from the transducer.

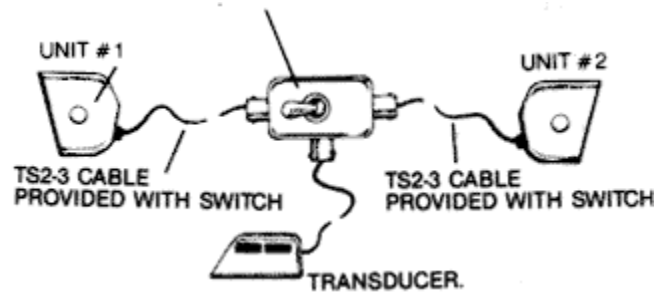

### INSTALLING THE CABLES

Your unit comes equipped with Humminbird's AngleLockT™ power and transducer connectors. The power connector is identified with the letter P on the back of the plug. It plugs into the outlet on the back of the unit marked "Power." The transducer connector is identified with the Letter T and plugs into the outlet on the back of the unit marked "Transducer." Note: An adapter (AD-4) is available to allow use of an old waterproof (BNC) transducer with the new Angle-Lock T™ connector.

A 1 1/8" hole must be drilled to pull the transducer connector through the dash. After drilling the hole, pull the transducer connector up through the hole. If you are installing two units, both transducer connectors can be pulled through this 1 1/8 inch hole. A hole cover has been provided which will dress and hold the wires. Install the hole cover after determining the necessary wire length from the hole.

The power cable has a red lead and a black lead. Connect this cable to a 12-volt DC Power Source (battery). Attach the red lead to the positive (+) post and the black lead to the negative (-) post. Install a 2 amp fuse between the red cable and positive post of your 12-volt battery.

If a fuse panel is available, we recommend wiring the power cable into the fuse panel. Note: The unit must be fused separately from any other accessory.

Your Angle-LockT™ connectors can only be plugged in one way. Position the connector so the letter P or T can be read and the 90 degree bend is pointed downward. Push the connector in as far as it will go. Turn the positive locking ring as far as it will go clockwise until you feel it lock. Your connector is now locked into place.

## MOUNTING SCREW INSTRUCTIONS

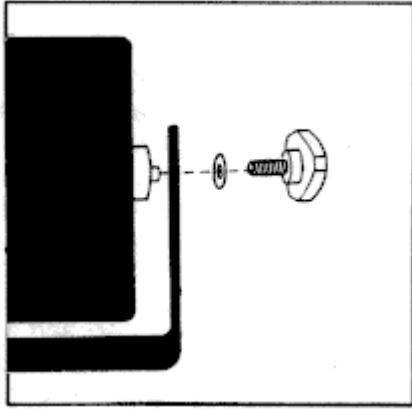

Important: Always use special flat washers provided with mounting screws when mounting unit to prevent breaking plastic knob due to overtightening. Washers must be installed as shown above between gimbal bracket and knob.

## IN-DASH UNIT

The first completely waterproof, flush-mount unit on the market. Fits snugly in the dash, is attractive and virtually theft-proof. Gives same great detail as the original Super Sixty. Operates from a single, independently mounted on/off switch, with built-in noise suppression.

## IN-DASH INSTALLATION INSTRUCTIONS

1. After selecting a location for your unit and control knob, check under the dash for clearance. 2. Drill a 3.5 inch diameter hole where you have chosen to put your unit. 3. Now slide your unit into the hole from the front side of the dash. (Note orientation of unit face before completing the following steps.)

4. Next, slide the mounting bracket over the bottom of the unit (see next page).

5. Install the flat washer, lock washer and nut onto the two bolts and tighten.

NOTE: Do not over tighten the hex nuts as this may cause damage to the unit. Do not apply Loctite or similar locking compounds to the unit or bracket as this may cause damage to the unit.

6. The OFF-SENS control of your unit requires a 3/e" hole in close proximity of the unit (due to cable length).

7. After drilling, install the off-sensitivity label by peeling off the back label and placing around the 3/e" hole.

8. On the blushing (threaded portion) of the control there are 2 hex nuts. Adjust one to accommodate the dash of your boat and the other to tighten. Now slide the black control knob onto the control shaft.

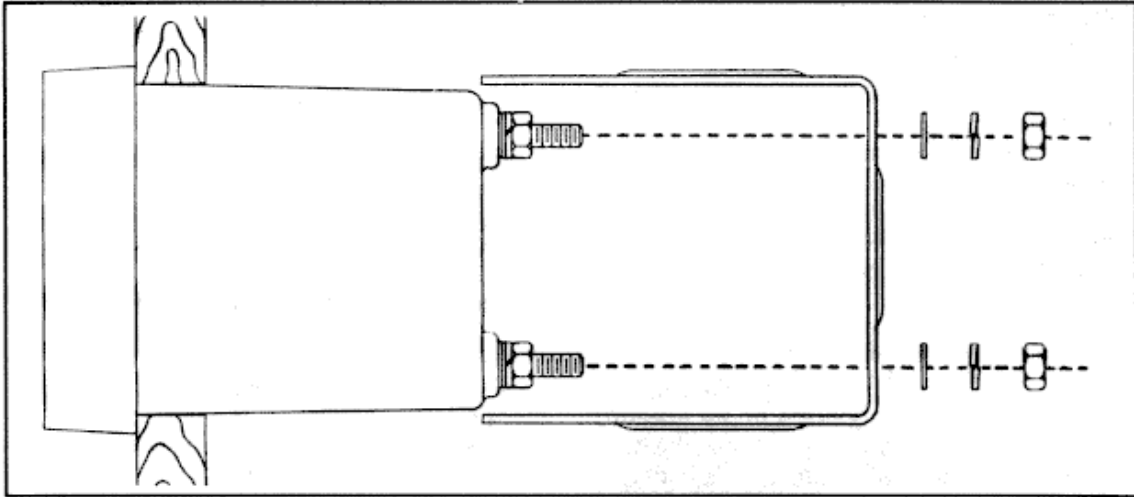

9. The final step is to connect the control cable and transducer to the unit. You may choose to mount your In-Dash Sixty in a location other than in the dash. This can be accomplished with the use of the Humminbird Bow Mount DBID. This bracket for the In-Dash allows the unit to be mounted on any flush surface such as on the console, bow or casting deck.



#### GENERAL OPERATIONAL INSTRUCTIONS

The OFF-SENS knob turns the unit on and off. This SENS (sensitivity) control also adjusts the circuit so the signal returned from the bottom is strong enough to produce a good display on the dial. If it is set to produce too strong a signal, echoes will appear on the dial at multiples of the water depth. This, however, should not be objectionable as long as the operator recognizes the echoes for what they are. The sensitivity control incorporated in this depth sounder is not a linear control. In other words, the change in sensitivity is very little for the % turn of the knob. The unit is designed in this manner in order to allow accurate readings in water which is as little as one foot deep. Because of this, however, it will be necessary to turn the knob to an almost fully clockwise position in order to obtain proper operation in deeper water. This does not mean that the sensitivity of the unit is lessened. Boat motors and other electrical devices can send out electrical noise that may show as erratic flashes on the dial. The NOISE REJECT knob adjusts the control head so these noise flashes cannot be seen. This knob is turned clockwise to reject noise pulses. See page 20 for noise reject adjustment instructions.



NOTE: The Humminbird In-Dash Sixty has a noise reject system built in.

NOTE: A large number of modern fishing boats are now equipped with two depth sounders, one of which is mounted on the console with the transducer positioned near the back. The second unit is positioned in front with the transducer mounted off the foot of the trolling motor. Occasionally, when both units are being operated with full gain, there will be a revolving signal flashing around one or both dials. This is a result of an overlap of signals due to the expanding cone angle of the transducer (See Figure 11). This same condition will occur when you pull alongside of another boat with its depth sounder in operation. This signal will not affect the performance of the unit and can usually be eliminated by reducing the amount of sensitivity. To avoid the possibility of the intermingling signals, the transducers should be positioned as far apart as possible upon initial installation.

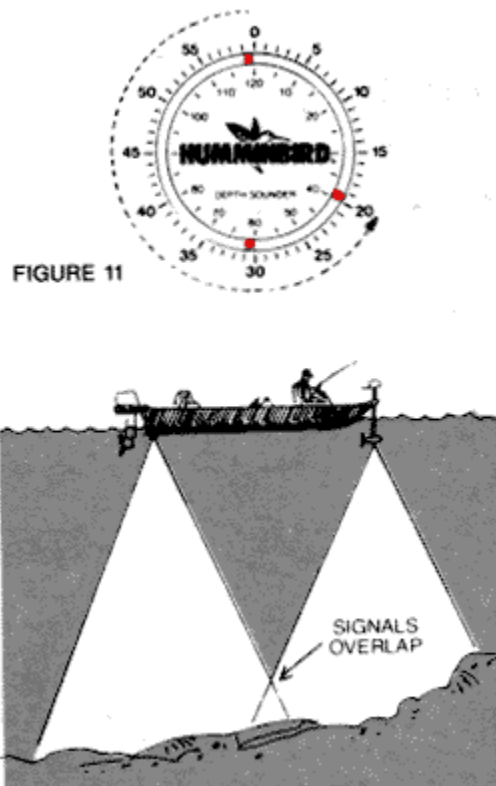

Refer to illustrations on page 18 as you read the following paragraphs.

### **OFF-SENS Adjustment**

Move the boat out into 5 to 10 feet of water. Shut off the boat motor and any electronic device that may cause electrical interference. Turn the NOISE REJECT knob fully counterclockwise. Turn the OFF-SENS knob just past the click. The dial should flash at 0 feet (see indication A). Turn the knob clockwise as needed to get a good lake bottom flash at the water depth (see indication B). Turn the knob farther clockwise and echoes will appear (see indication C). As a rule of thumb, adjust the sensitivity clockwise until you see the second echo (indication C). This will normally give you good bottom and fish returns.

In order to allow readings in very shallow water (one to five feet) the SENS control has a special taper which requires that it be turned almost fully clockwise to read depths over 30 to 40 feet. This in no way means that your unit is not sensitive as it will read depths up to 200 feet. This control does, however, allow more control of your signal at shallow depths.

**DIAL**  
(0-60 feet)

**NOISE REJECT**  
Turn Clockwise  
far enough to eliminate  
interference flashes.



**OFF-SENS**  
Turns the Control Head  
on and off. Adjust for good  
lake bottom flash.

**CONTROL HEAD**

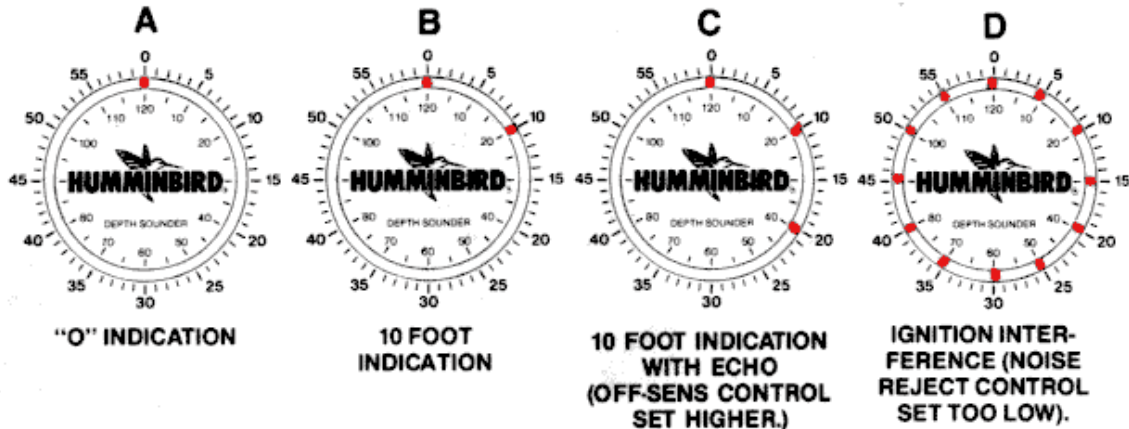

## NOISE REJECT ADJUSTMENT

NOTE: When the NOISE REJECT knob is turned clockwise, the amount of the reflected signal may be slightly reduced. Therefore, turn this knob clockwise only as far as needed to reduce interference. If there is no interference, this knob can be left in the full counterclockwise position.

NOTE: The Humminbird In-Dash Sixty is the only model with a NOISE REJECT system built in.

Start the boat motor and look for a flashing, moving pattern that covers the circumference of the dial (see indication D). If these flashes cannot be sufficiently reduced by turning the NOISE REJECT knob clockwise, reposition the transducer and cable away from the motor to obtain a minimum number of interference flashes. Then turn the NOISE REJECT knob as far clockwise as is necessary to reduce the interference. If the interference still cannot be sufficiently reduced, contact the motor manufacturer for information on reducing ignition interference.

## HOW TO READ THE DIAL

Objects Under Water A lake bottom is seldom level or uniform, and objects in the water or on the bottom may also vary in depth. The dial readings will indicate these varying conditions accordingly. To distinguish between the dial indications of rocks and fish, anchor the boat and watch for signals that change. A changing signal will usually indicate a moving fish.

Pages 23 through 25 show you examples of underwater conditions and dial readings. Study these drawings for help in interpreting what you read on the dial.

NOTE: For additional information and illustrations showing the interpretation of the depth sounder readings, refer to the "Humminbird Trouble Shooting and Consumer Information Guide."

This booklet is available at no charge from Humminbird Customer Service Department. i-800-633-1468. Alabama residents should call 1-800-821-8315.

## HARD CLAY, SAND, GRAVEL, SHELL BOTTOMS

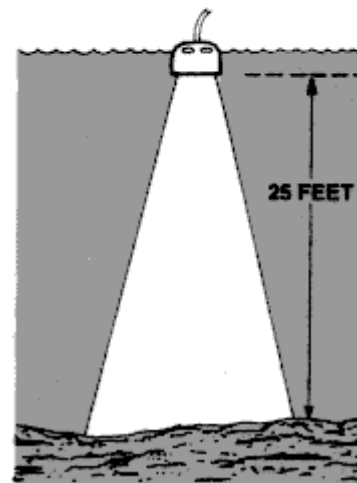

**ROCKY BOTTOM**

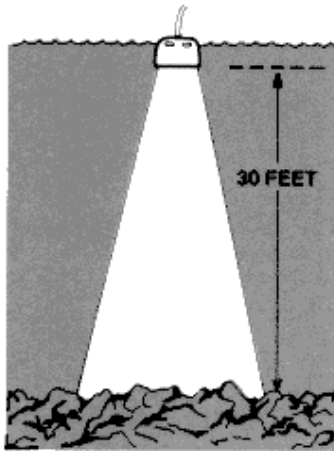

**FLAT MUDDY BOTTOM**

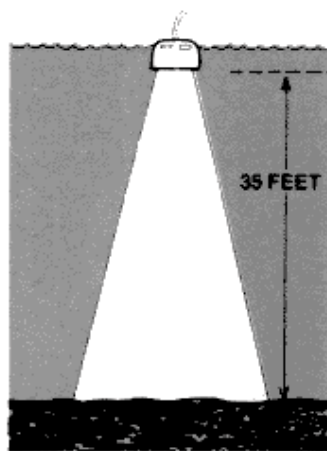

**SOFT BOTTOM WITH BRUSH OR VEGETATION**

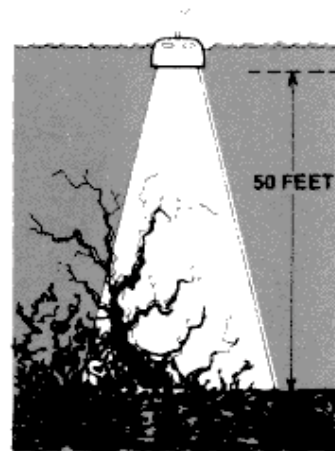
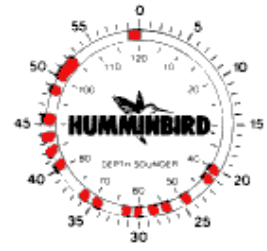

**STEEP, ROCKY LEDGES**

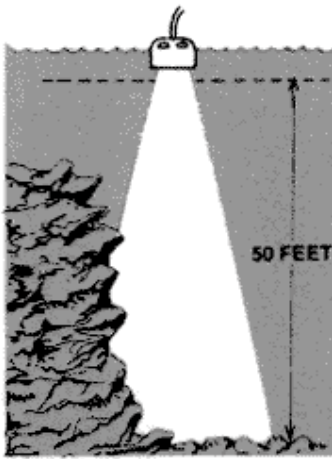

**SMALL FISH OVER AN UNDERWATER CLIFF**

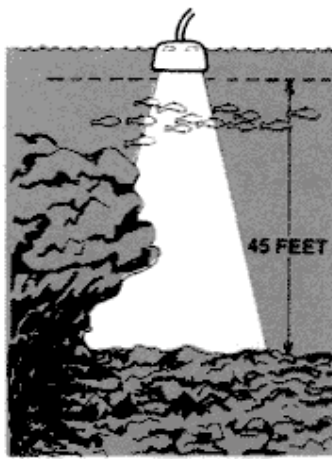

**WIDE SIGNAL INDICATES LARGE FISH**

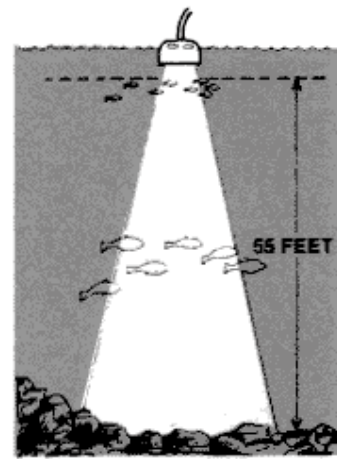

**OPERATION OF THE SUPER THIRTY 11 IN VERY SHALLOW WATER**

The Humminbird Super Thirty II will operate in the same manner as our Super 60 except the unit with its wide graduations is ideally suited for shallow water applications. This unit measures to 30 feet on the first revolution and will operate satisfactorily in water depths of 100 feet or more. Since the unit is designed for shallow water, we recommend that it be mounted forward and in conjunction with a trolling motor mount. In certain areas of the country, such as Florida, where many bodies of water rarely exceed 30 feet in depth, the Super Thirty II can be successfully used as a console mount. When operating the Super Thirty II in water deeper than 30 feet, simply move the selector switch to the 60 foot setting. The range on the first revolution will then be up to 60 feet as shown on the inner dial.

The slightest change in depth can readily be detected with the Super Thirty II. We recommend you start with a minimum amount of gain, and increase it as needed.

If the depth continues past 60 feet, the bottom signal will continue past zero and you will continue to get an accurate depth reading by adding the additional depth to 60 feet.

**OPERATION OF THE SUPER SIXTY AND IN-DASH SIXTY MODELS IN WATER DEEPER THAN 80 FEET**

When operating the Humminbird Super Sixty and the Humminbird In-Dash Sixty depth sounders in water deeper than 60 feet the flash will continue past zero, and at this point the inside dial should be read. The inside dial reads up to 120 feet. For depths greater than 120 feet (two complete turns around the dial) add 120 feet to outer dial reading where the flash stops.

## BIRDTRAP

The Birdtrap allows you to make a portable unit of any permanent mount Humminbird Depth Sounder except the In-Dash.

Follow the installation instructions received with your portable Birdtrap, then refer to the operational section of this manual for proper use.

Batteries should be the type with the curled up wire tops. They should be placed side by side, upright in the battery compartment in the front of the Birdtrap. See "BATTERY CONNECTION DIAGRAM" on page 30 for proper wiring instructions.

60 FOOT-DIAL INDICATIONS FOR VARIOUS DEPTHS  
(Add 60 Ft. For Each Complete Turn Of Dial)

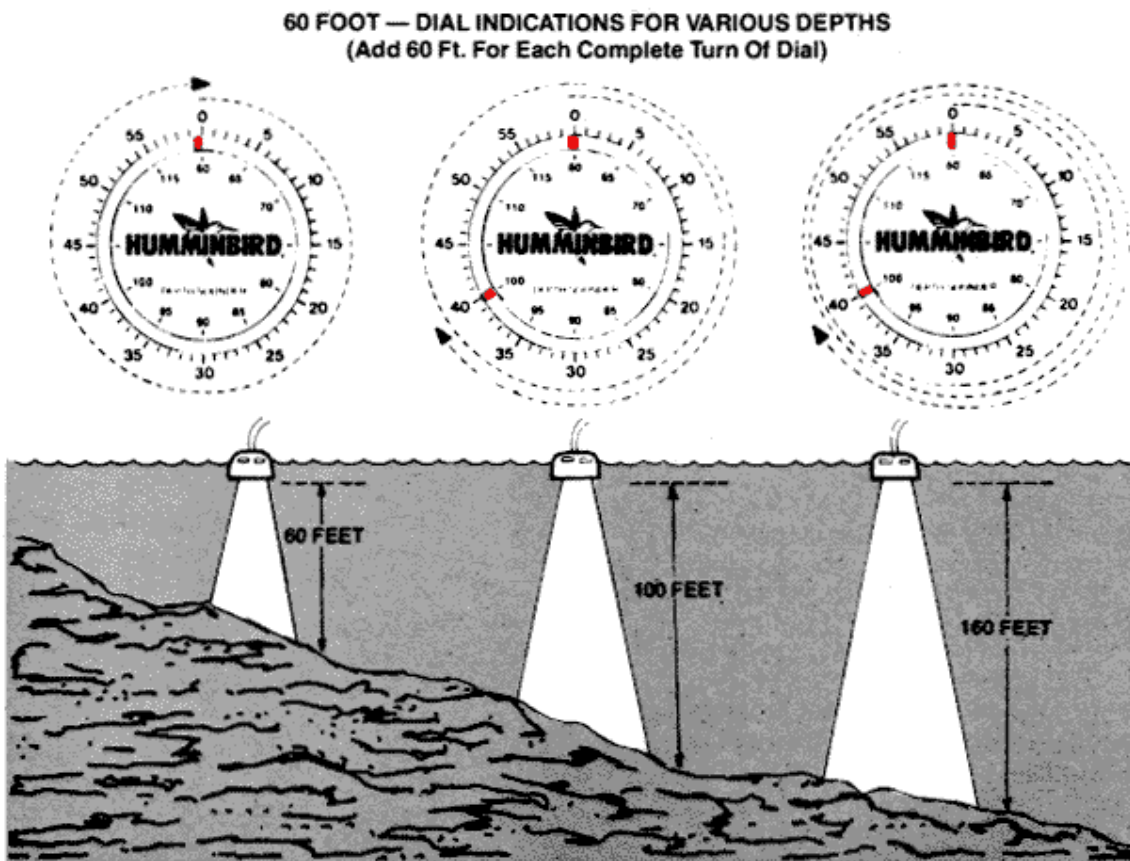

SMALL AND LARGE FISH IN DEEP WATER

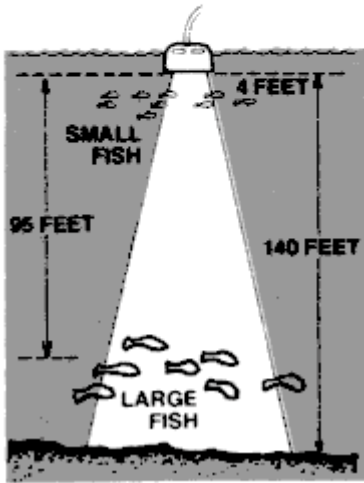

The Birdtrap is used in the same manner as a permanent mount unit. The transducer may be mounted using the suction cup as shown in Figure 12 or, if you have a fiberglass boat with a single hull, the transducer may be placed in a small amount of water in the hull of the boat.

NOTE: The water must be in direct contact with the hull of the boat.

There cannot be any air between the bottom of the transducer and the hull of the boat.

The metal finger (with the yellow tip) is designed to hold the suction cup onto the boat at idle or slow speeds. DO NOT use this finger as a handle to remove the suction cup. When running at medium to high speeds you should first take the transducer out of the water because the suction cup cannot hold at these speeds.

## PORTABLE TRANSDUCER ASSEMBLY

Follow illustration instructions.

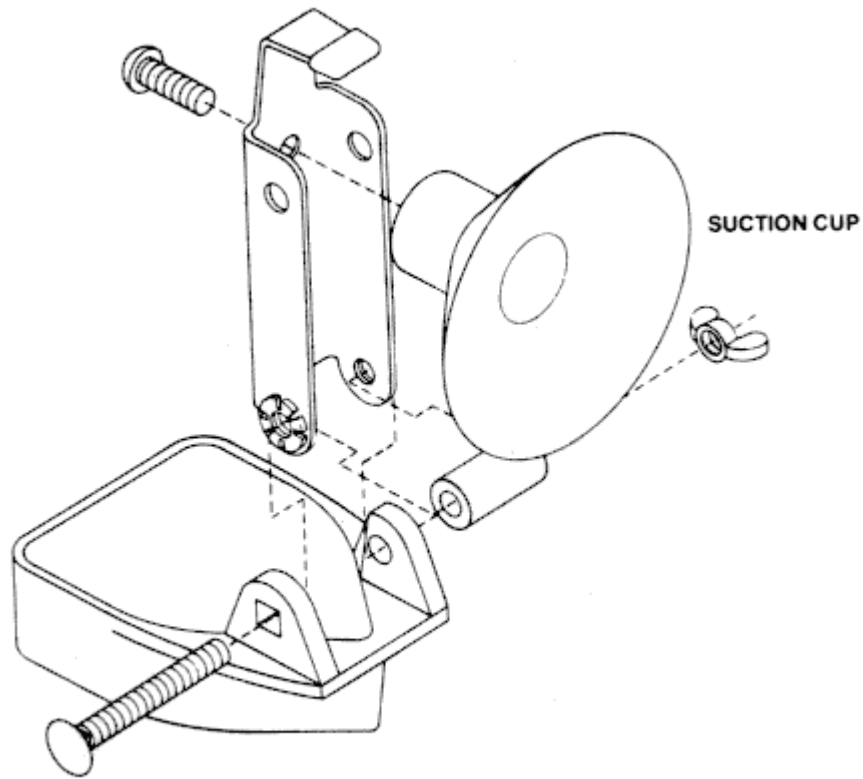

**FIGURE 12**

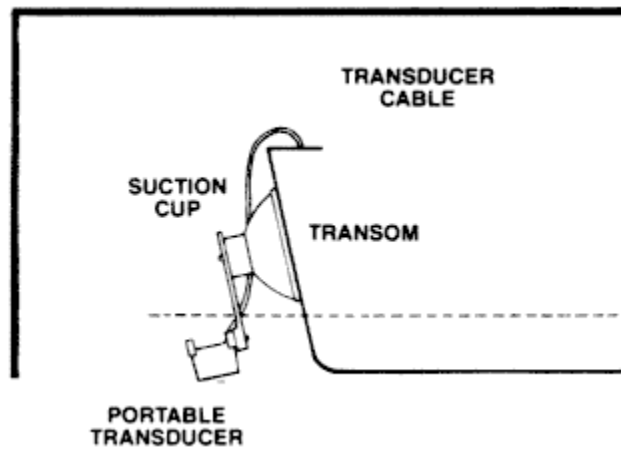

**CAUTION:** You should tie down the transducer cable, so that if the suction cup comes loose it will not allow the transducer to be damaged by the propeller or possibly pull the unit out of the boat. Humminbird will not be responsible for any damage due to the suction cup becoming loose.



## INSTRUCTION DIAGRAM FOR CONNECTING 6 VOLT BATTERIES TO PORTABLE BIRDTRAP

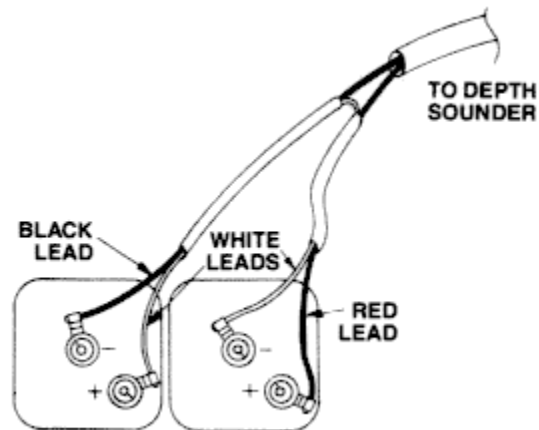

Use two six volt lantern batteries with spring terminals. Connect as shown above.

### BATTERIES

All Models operate from the 12 volt system on your boat or a 12 volt dry cell source. The dry cell source may be two 6 volt cells connected in series.

Replace or charge the batteries when you notice that the dial motor has slowed down. This indicates that the battery voltage has fallen below 10 volts and this low voltage will cause the dial lamp to flash at less than the actual depth.

NOTE; A weak battery will sometimes cause the lamp not to flash even though the motor still runs.

NOTE: If the lamp on your depth sounder does not flash or flashes intermittently, check your battery connections. Very often a battery will operate your trolling motor or crank your outboard motor, but still not have enough voltage to operate the depth sounder. This is due to the fact that trolling motors and starter motors are current sensitive whereas the depth sounder is voltage sensitive.

## ICE FISHING WITH THE BIRDTRAP

The Birdtrap provides an excellent aid to ice fishermen. The unit will read accurately when placed on top of the ice provided that a little moisture is formed beneath the transducer.

NOTE: This procedure does not work if an air gap develops between ice and water.

A small amount of water poured on the surface of the ice will provide a suitable puddle in which to place the transducer. Schools of fish can often be located before drilling holes, thus saving time and energy on the part of the fisherman.

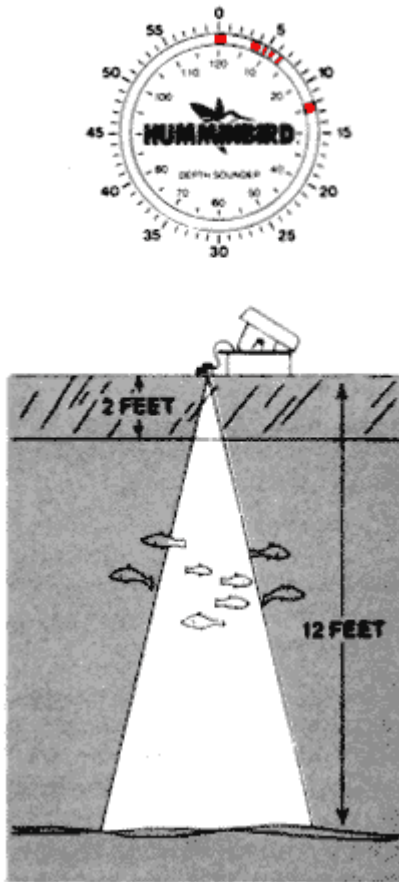

In extremely cold temperatures, battery life can be extended by placing the Birdtrap inside a styrofoam insulated chest. A small portable hand warmer placed beneath the unit will also help conserve the batteries.

## HUMMINBIRD TROUBLE SHOOTING GUIDE

Your Humminbird depth sounder is engineered and manufactured with care and precision and is tested time and time again before leaving our plant. Each unit is backed by a written warranty and is guaranteed to perform to your satisfaction.

We have found that in many cases, problems arising with the operation of a Humminbird can be traced back to a minor error in installation or an oversight on the part of the operator.

If you should ever experience any operational problem with your Humminbird, please refer to the following Trouble Shooting guide. If, after checking the various areas described, you are still experiencing problems, we would suggest you return your unit to our plant for repair.

NOTE: Please keep this operations manual in a convenient spot, where it is easily accessible. Also save the original carton your Humminbird came in, in case you should ever need to return it for service.

#### Multiple Flashes at Regular Intervals

If the OFF-SENS knob is turned too far clockwise, the signal will bounce back and forth several times between the bottom and the boat. This will cause flashes at multiples of the depth reading. CURE: Turn the OFF-SENS knob counterclockwise until you get a good bottom reading.

#### Unusual Readings

The signal that is reflected back to the transducer from the bottom, or fish, must be strong enough to produce a good clear flash on the dial. Weak flashes or no flashes at all usually indicate that the OFF-SENS knob is turned too far counterclockwise, that you are above deep, decayed vegetation, or that you are in water over 200 feet deep. In the last two cases, the signal would probably be absorbed by the bottom or never reach it.

If the NOISE REJECT knob is turned up too high, some of the signal may also be lost.

#### Motor Does Not Turn

Check power cable contacts.

#### No Light

Reverse wires at the battery.

#### Motor Turns, No Light

Check voltage input to depth sounder, 10 volts minimum.  
HUMMINBIRD TROUBLE SHOOTING GUIDE (continued)

Motor Turns, "0" Lights, No Bottom Reading Turn sensitivity knob full clockwise, noise rejection knob full counterclockwise. Plug and unplug transducer connector "0" reading should increase in width when transducer is plugged in.

Rub water into the face of the transducer to provide for proper wetting.

Check for cuts in cable.

If transducer is mounted inside boat, refer to page 10.

Cannot Obtain High Speed Reading If transducer is mounted inside boat, refer to page 7. If transducer is mounted on outside of boat, check to see that transducer is on driver's side and is flush with the bottom and transom of boat. Tilt back of transducer slightly down to insure transducer stays in contact with the water during high speed operation.

Be sure transducer is clear of ribs, rivets or other protrusions that may cause air bubbles to pass under the transducer.

Cannot Obtain Deep Reading If mounted inside boat, be sure transducer is properly installed with fiberglass or epoxy resin. If transducer is inside the hull and is not bonded to the hull, the area must be filled with clean water, free of oil.

Be sure transducer is pointing as straight down as possible with boat in the water.

Proper Operation of Depth Sounder Noise rejection control should be at a minimum setting which will eliminate any electrical noises which are shown as erratic and random flashes on the depth sounder.

Sensitivity control should be at a maximum setting just creating a double echo on your depth sounder. Think of the sensitivity control as the volume control on your radio - the deeper the water, the more control (clockwise) required.

#### Humminbird Service Policy

The best products in the industry are backed by the best service policy in the industry. Even though you'll probably never need to take advantage of our incredible service guarantee, it's good to know that we back our units this well. We do it because you deserve the best.

**One-Year Full Warranty** First-year repairs on your unit will be made absolutely FREE (physical damage not included).

**Limited Maximum Service Charge** After the warranty period, a limited maximum service charge is the most you will pay for each repair (physical damage and missing parts not included).

**Factory-Trained Technicians** All repair work is performed by factory-trained technicians to meet exacting factory specifications.

**Strictest Factory Testing** Factory-serviced units go through the same rigorous quality-control inspections and full burnin as new units.

At Humminbird, our goal is to serve our customers with only the highest level of quality, in our products and in our service. This service policy is valid in the US and Canada, applies only to Humminbird units returned to our factory in Eufaula, Alabama, and is subject to change without notice.

If for any reason your HUMMINBIRD unit fails to operate within one year of date of purchase, TECHSONIC INDUSTRIES, INC. will repair it at no charge except for the following items:

1. You will be charged for any lost parts.
2. You will be charged for repair of any physical damage.
3. Transportation charges will be the responsibility of the purchaser.

**THIS IS A FULL WARRANTY AS DEFINED BY THE FEDERAL WARRANTY ACT, EFFECTIVE JULY 4, 1975.**