



HUMMINBIRD

BY TECHSONIC 

The ultimate in fish-finding technology.

LCR 4x6TM

*The big screen with
picture-perfect detail*

Operations Manual

Before attempting to install or operate your Humminbird LCR it is recommended that you read the operations manual thoroughly. The LCR has a number of special features not found on any other depth sounder. Therefore, to completely understand all the features we suggest you follow the instructions in this manual. If, after reading the instructions, there is something you do not completely understand about the operation of your unit, we recommend you contact our Customer Service Department-CALL

334-687-0503

Our Customer Service hours are Monday- Friday 8:00 A. M.-5:00 P. M.

Please complete your warranty card and return it to us immediately.
Thank you.

INTRODUCTION

Congratulations on selecting the LCR4x6. Your new Humminbird LCR incorporates the most advanced, innovative concepts in sonar equipment. The LCR is probably the most intelligent depth sounder ever created. Advanced microcomputer technology is used to simplify its operation, not complicate it, so you can quickly learn the basics of operating your unit. You will find even the advanced features, such as Split Screen Zoom and Screen Memory, are easy to learn and fun to use.

Your Humminbird LCR has a number of outstanding features including a unique automatic feature. This computer-controlled feature, pioneered by Humminbird, makes using your LCR as simple as pushing the "Power" button. The computer will automatically adjust the sensitivity, change the depth scale even if the bottom goes off the screen and black out everything below the bottom to make the display easy to read.

The LCR4x6 control panel is another Humminbird innovation. You have complete control of all the unit's features with just seven buttons and an easy-to-understand display of all adjustments is right on the screen. You will quickly see that the advanced technology of the LCR4x6 is easy to use and understand.

Other features include Split Screen Zoom and Bottom Lock, Screen Memory, Total Screen Update, large digital bottom depth readout, Fish Alarm, Bottom Alarm, and optional Surface Temperature and Speed Gauges for readings on the LCR screen.

The LCR has a large 6-inch by 4-inch visibility LCD, a night-light, waterproof enclosure, and a low profile swivel mount. Read this operations manual thoroughly to get the most from all the LCR's features. You'll have fun learning to use your LCR4x6 and it will give you many hours of fishing and boating pleasure.

THEORY OF OPERATION

You Humminbird LCR works on the basic principle of sonar. An electronic signal is generated within the control head of the unit. When coupled to the transducer, this signal is converted to an ultrasonic signal and is transmitted toward the bottom. The speed of the ultrasonic signal travelling through the water is approximately 4800 feet per second.

The signal travels through the water until it strikes an object or the bottom. At this instant it is reflected back, picked up by the transducer, reconverted to an electric signal and is recorded on the display of the LCR.

The reading at the far right position of the screen shows what is being passed over at that time. As new information is received, the old information is shifted to the left and the new information is added. The information is retained until it disappears from the left side of the screen. Figure 1 illustrates a typical display.

One of the unique features of your LCR is the Split Screen Zoom with Total Screen Update. Figure 1 shows a Split Screen Zoom display with the full depth range information on the right and

the expanded view on the left. The Total Screen Update feature is explained in detail later, but basically with the Zoom the Total Screen Update allows you to zoom in on an area even after you have passed by it. The display resolution on the expanded portion of the screen is as good as $\frac{3}{4}$ inch per dot, giving you exact detail while still viewing the full depth range information on the right.

The display technology used on the LCR4x6 has been pioneered by Humminbird. The display uses Advanced Super Twist Liquid Crystal Technology for the best contrast, widest viewing angle and extreme high and low temperature operation.

The Super Twist Liquid Crystal material in the display is a liquid that can be aligned such that it either "blocks" light or it lets light pass through. The "blocking" of light is what makes the black dots on the screen.

Since the LCR's display depends on light passing through it to make the images, increasing the light source will make it easier to see. This is why your LCR can be seen so well in direct sunlight. You will also notice that the display can be seen better at certain angles. The LCR mounting has been designed for tilting and pivoting so that you can easily maintain a good angle for viewing. Another characteristic of an LCR display is that you may find that some polarized glasses might affect the view by causing a rainbow prism to appear. This condition can possibly be improved by a slight adjustment in tilt.

SPLIT SCREEN OPERATION

The LCR4x6's split screen feature will allow you to make side-by-side comparisons. You will be able to split the screen and compare actual, full depth scale information with three functions-1.) Zoom, 2.) Bottom Lock, or 3.) Screen Memory.

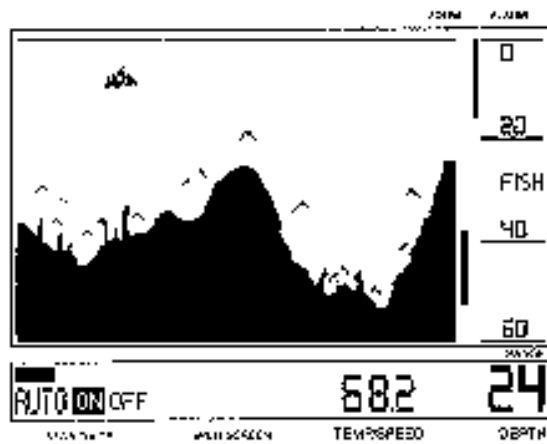

FULL DEPTH RANGE
SHOWS ALL THE INFORMATION FROM 0 TO 80 FEET

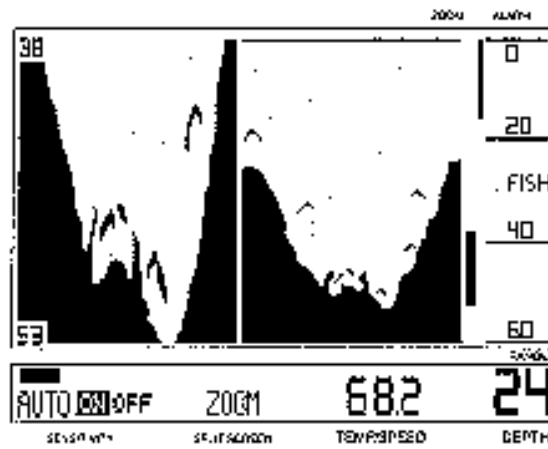

SPLIT SCREEN ZOOM
THE LEFT SIDE OF THE SCREEN SHOWS AN EXPANDED VIEW
FROM 38 FEET TO 53 FEET

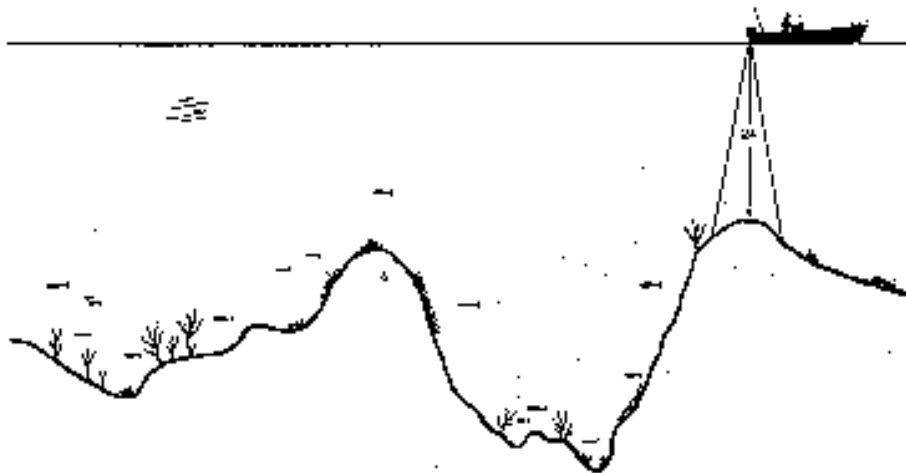
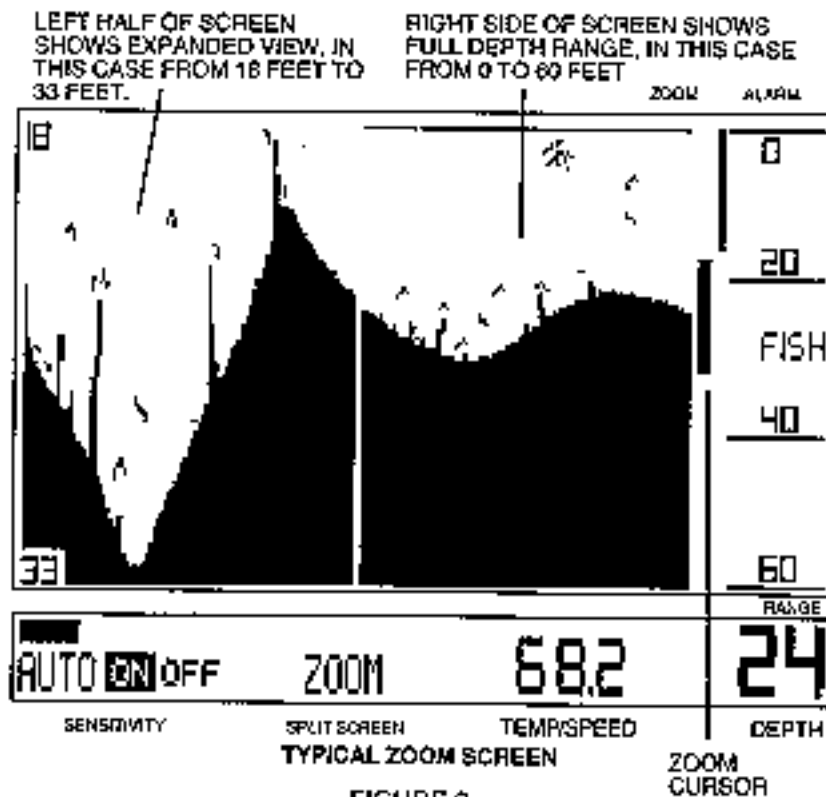

FIGURE 1

The use of the split screen is very easy. Whenever any of three functions, Zoom, Bottom Lock, or Screen Memory, is turned on the screen automatically splits.

<p>LEFT HALF OF SCREEN SHOWS SHOWS EXPANDED VIEW, IN CASE THIS CASE FROM 18 FEET TO 33 FEET</p>	<p>RIGHT SIDE OF SCREEN FULL DEPTH RANGE, IN THIS FROM 0 TO 60 FEET</p>
---	---



When Zoom is activated, for example as shown in figure 2, the left half of the screen any shows the expanded information while the right half shows the full depth scale information. The Zoom range can be moved up or down to search out any area. Even the depths of the upper and lower part of the Zoom region are digitally displayed for precise location of fish and structure.

The bottom lock and screen memory work in the same way to give you the benefit of split screen comparisons. The detailed operation of each of these functions is explained later in this manual.

TOTAL SCREEN UPDATE

Total Screen Update was invented by Humminbird engineers. You will find this unique feature very useful and beneficial. It will allow you, when changing depth scales, for example, to totally change the entire screen to the new depth scale. It will also allow you to ZOOM in and look at information in much finer detail even after you have already gone over the area.

HOW DOES TOTAL SCREEN UPDATE WORK?

Memory devices inside the LCR4x6 can store hundreds of thousands of bits of information Automatically, while you are operating the unit, the computer is putting information into the LCR's memory.

All this information is being put into memory in much smaller increments (pieces) than is being displayed on the normal full depth scale. For example, on the 0 to 30 foot range-each dot is equal to 3 inches, or on the 0 to 60 foot range each dot is 6 inches, and so forth. But in the LCR4x6's memory information is being stored such that when you Zoom in on a 7 1/2 foot increment each dot represents an incredible $\frac{3}{4}$ inch per dot.

HOW TO USE TOTAL SCREEN UPDATE

It is very easy to use Total Screen Update because the LCR's computer will do everything automatically. You will notice how Total Screen Update works when a depth range changes. When the bottom display goes off the screen, The LCR4x6 will automatically change to the next deepest range and update the entire screen to the next deepest range and update the entire screen to the new depth range. This Total Screen Update feature also works when changing to shallower scales. For example, suppose you are in the 0 to 120 foot scale but the bottom depth changes quickly to 20 feet. When the depth range is changed to the 0-30 foot scale , the entire screen will look just as if you had gone over the area on the 0-30 foot scale.

Another way that you will use Total Screen Update is in operating the LCR's Zoom or Bottom Lock. Since the computer has stored in memory information in very small increments, you will be able to recall this information from memory to get an expanded view of areas which you have already passed over.

For example, if you go over some interesting structure or fish, you will be able to Zoom in for a closer look without going back over the area by simply activating the Zoom. The information that is stored in memory will automatically be recalled and displayed on the left side of the screen. The operation of Zoom is explained in a later section.

The high visibility readout of the LCR allows you to see fish, bottom contour and underwater structure.

The LCR is designed to operate with a standard 16 degree transducer included with the unit. Other transducers, such as 32 degrees, cannot be used. In order for your LCR to operate well at high speeds, you must have a properly mounted transducer. Please read the transducer mounting procedure carefully.

TRANSDUCER MOUNTING PROCEDURE

Humminbird's high speed transducer is supplied with your LCR. This transducer has been designed to give good high speed readings on most all boat designs, including aluminum.

Please carefully consider the following before installing your transducer.

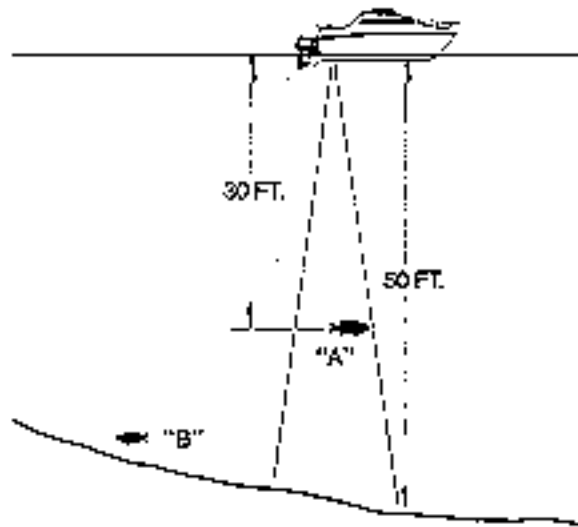
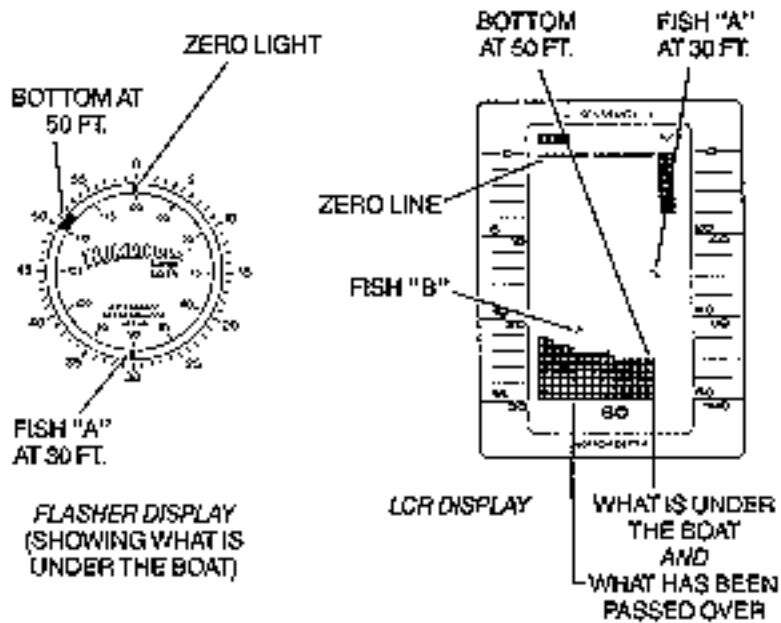

FIGURE 1

TRANSDUCER MOUNTING OPTIONS

- A. **Transom Mount-** The Humminbird high speed transducer allows the transducer element to be mounted below the bottom of the boat hull keeping the transducer out of turbulent water and insuring good high speed operation. The transducer will absorb the blow of any obstruction by rotating up out of the metal spring bracket without harming the transducer, or your boat. The transducer can be re-engaged by simply rotating the transducer down and snapping it back in place. (See Figure A)

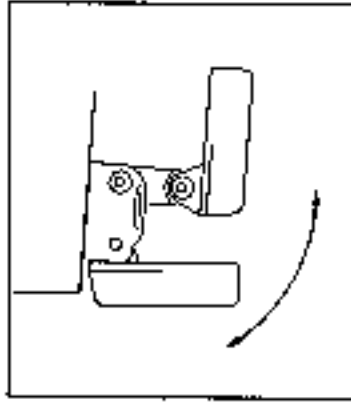

Figure A

- B. Inside Hull Mount- The high speed transducer can be mounted inside the hull (without pivot assembly) using the proper two-part epoxy, such as Humminbird's epoxy kit. Even though there is some loss of signal in shooting through the hull, your LCR will perform well with this type of installation. You cannot shoot through the hull of an aluminum boat.
- C. Trolling motor Mount- This type of transducer is not supplied with your LCR. It is designed to mount on the foot of a trolling motor. You may exchange your un-used high speed transducer for a trolling motor transducer. Call the Humminbird Customer Service Department.
- D. Bronz Thru-Hull Mount- This transducer is not supplied with your LCR but for an additional cost you may exchange your un-used high speed transducer for a bronz thru-hull. The bronz thru-hull transducer has a threaded stem which installs through a hole drilled in the boat hull, leaving the housing exposed under the boat. This type of installation must be used for many boats with in-board engines, because there is no suitable location on the transom away from the noise and turbulence created by the prop. A bronz thru-hull transducer should be installed by qualified personnel only.

The LCR will operate well at high speeds with a properly mounted transducer. Remember, a transducer will not work transmitting through air or through air bubbles.

1. TRANSOM MOUNTING PROCEEDURE

Step 1.

MOUNTING LOCATION- It is important that the transducer be mounted on the transom where water flow is in constant contact with the transducer. You may wish to observe the rear of the boat while it is moving through the water to determine the best mounting location.

Step 2.

BRACKET INSTALLATION (Aluminum Boats)- To install the metal bracket on an aluminum boat locate the template on the transom between rows of rivets, or ribs that are on the bottom of the boat. Align the template so that the bottom corner of the template nearest the center of the transom is on the bottom edge of the transom.

Figure B

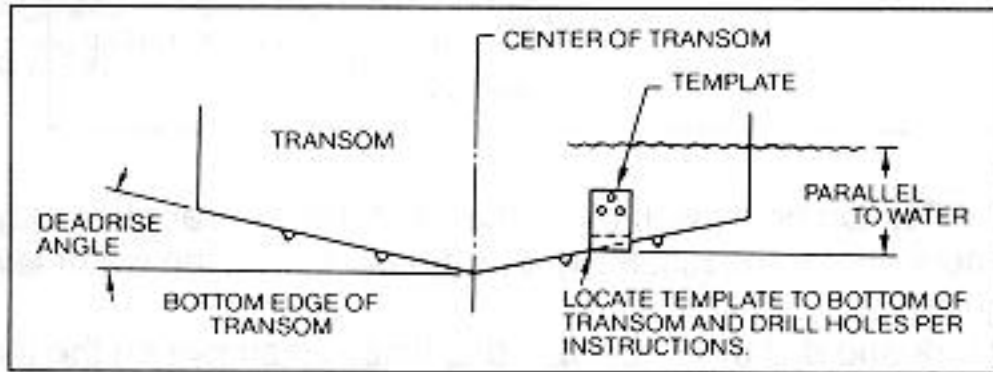

Once the location is determined mark and drill three 7/64" dia.. holes noted on the template. Attach the metal bracket using three #10 self threading screws supplied. Be sure to align holes in the center of the Bracket slots. On some aluminum boats it may be necessary to use a wood back-up plate. It is important to use a silicone sealant between the screwhead and bracket in order to prevent leaking. (See Figure C)

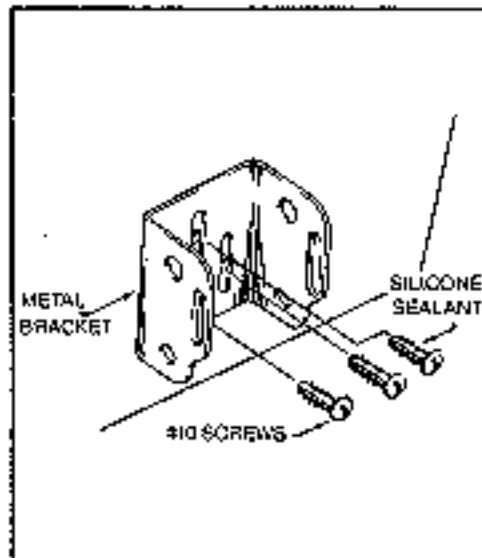
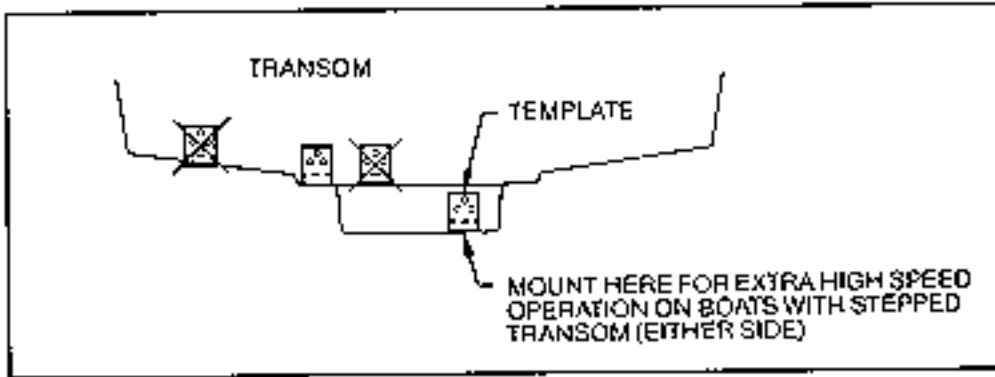

Figure C

Step 2.
BRACKET INSTALLATION (Fiberglass Boats)- If your boat has a stepped transom located below and under the main transom, the compact transducer design allows mounting in this area. This mounting location is recommended for good reading at very high speeds. (See Figure D)

To install the metal bracket on a fiberglass boat, locate the template on the transom in the same manner as for an aluminum boat. (See Figure C)

Figure D



NOTE: On boats with more than 15 degree deadrise angle it may be necessary to mount the transducer slightly off parallel with the water level. (See Figure E)

Mark and drill the three 9/64" dia. holes as shown on the template. Attach the metal bracket using the three #10 self threading screws supplied. Be sure to align the holes so that they are centered vertically in the three slots found in the bracket. It is important to use a silicone sealant between the screwhead and bracket in order to prevent leaking.

Figure E

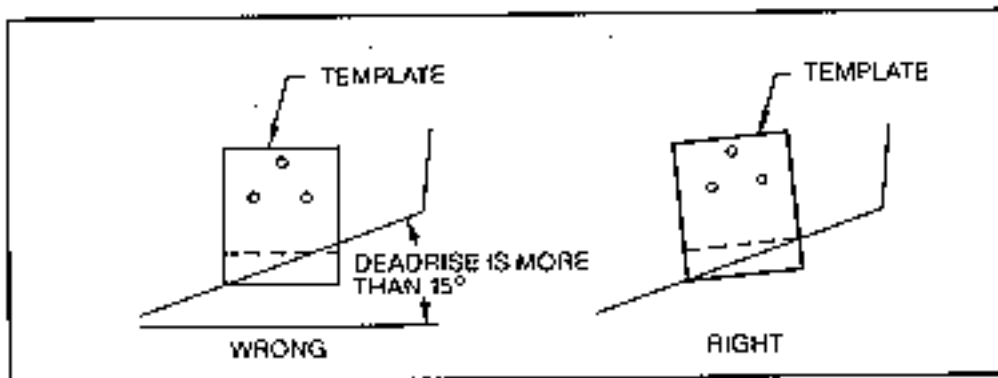

Step 3.

TRANSDUCER PIVOT ASSEMBLY- Assemble the pivot to the transducer main body using the two 1/4"x5/8" allen head screws, two 3/8" tooth washers and two, 1/4" square nuts. Make sure the tooth washers are sandwiched between the transducer main body and the pivot. The square nuts are trapped inside the pivot and will not rotate as the allen head screws are tightened. HOWEVER, DO NOT TIGHTEN AT THIS POINT. (See Figure F)

CAUTION: DO NOT APPLY LOCTITE® OR SIMILAR LOCKING COMPOUNDS BECAUSE THEY WILL ATTACK THE PLASTIC.

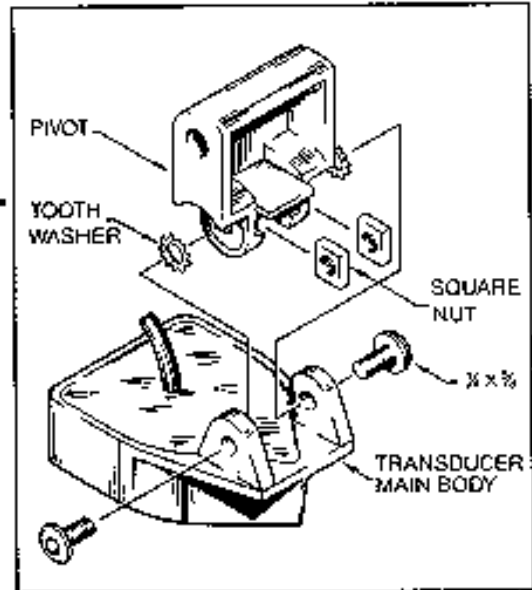

Figure F

Step 4

TRANS-DUCER ASSEMBLY- Insert the transducer assembly into the metal bracket from the bottom. Push up until the holes in the plastic pivot align with the uppermost holes in the bracket. Slide the O-ring on to the headed pin and insert it through the two parts. Assemble by screwing the 1/4"x3/8" allen head screw into the end of the pin and tighten. (See Figure G)

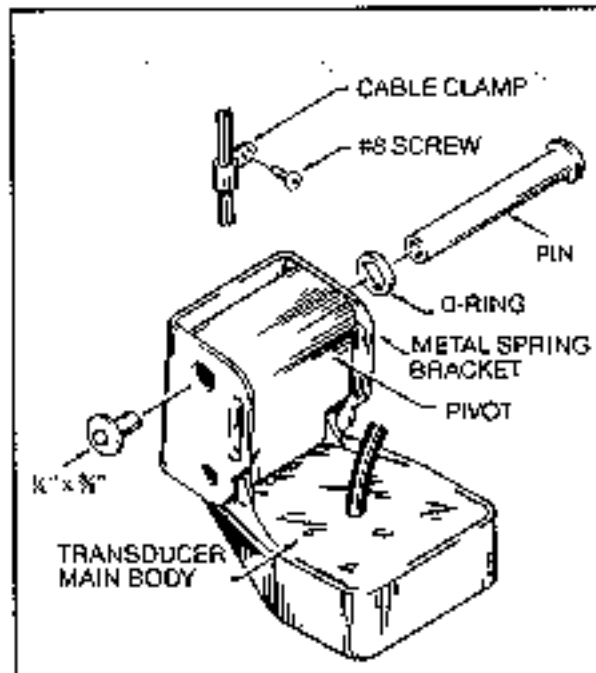

Figure G

Step 5

ANGLE ALLIGHMENT- Set the transducer angle so that it is parallel with the bottom of the boat hull. Once proper alignment is achieved, tighten the two allen head screws using the 5/32" allen

wrench provided. The screws are visible through the access holes on each side of the metal bracket. Check to make sure the transducer main body is rigidly fastened to the pivot. (See Figure H)

Figure H

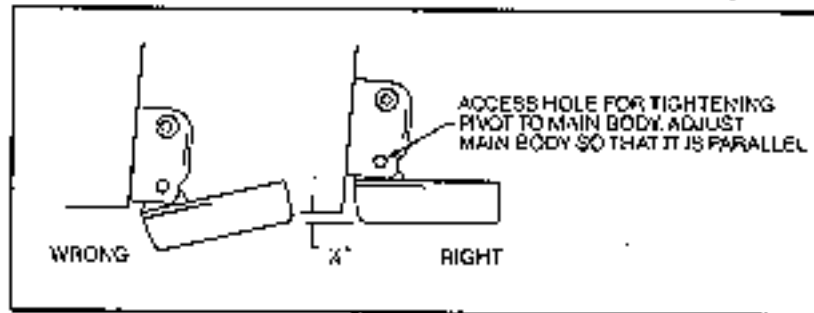

Step 6

CHECK POSITION OF TRANSDUCER- At this point, check to see that the bottom of the transducer is a minimum of $\frac{1}{4}$ " below the bottom of the transom. (However, as noted in STEP 2, the top of the transducer can not fall below the bottom of the transom). If it is not, remove the transducer assembly from the metal bracket by removing the pin installed during STEP 3. Loosen the metal bracket mounting screws, re-position the bracket utilizing its slotted holes, tighten and re-assemble. It may be necessary to replace the silicone sealant after this adjustment is made.

NOTE: It may be necessary to make several high speed runs to adjust transducer either UP/DOWN or to re-adjust the angle to achieve optimum results.

Step 7

CABLE CLAMPS- Install cable clamps as necessary by drilling a $\frac{1}{8}$ " dia. hole for the # 8 screw supplied.

2. INSIDE HULL MOUNTING PROCEDURE

Warning: In order to achieve proper results with this type installation, it is important that the transducer be mounted by someone familiar with the use of two part epoxy adhesives. For this reason, Techsonic Industries, Inc. will not be responsible for any damage due to the mounting of your transducer in this manner.

NOTE: An Epoxy Kit (Part N. EPK) is available from Humminbird. This Epoxy Kit has been formulated for Inside Hull Transducer Installation.

1. Select as flat an area as possible near the aft end and center of boat where the hull is thin and not double. If the bottom has a runner down the center of boat, select an area to one side of the runner, but as close to the runner as possible.
2. Clean the inside of the boat with lacquer thinner in the area transducer is to be mounted. Outside of boat in this area should also be cleaned. (Not with lacquer thinner).
3. Put approximately one inch of water in the bottom of the boat.
4. Put transducer in the water. The bottom of the transducer should be in a flat area and should be in good contact with the bottom of the boat.
5. Operate the LCR with the boat operating at high speed. The transducer may have to be moved in order to find an area where satisfactory operation is observed.

6. When an area is found that produces satisfactory operation, mark the location of the transducer.
 7. Remove the water and transducer and clean the marked area and the bottom of the transducer thoroughly.
 8. Using the Humminbird Epoxy Kit or equivalent, mix an ample amount of epoxy without causing it to bubble and pour it in the area the transducer is to be mounted. The puddle should be larger than the bottom of the transducer.
 9. Coat the bottom of the transducer with epoxy, then put it in the center of the puddle and push down on the transducer while moving it around in a circular motion. This forces out any air bubbles that may be trapped between the bottom of the transducer and the hull of the boat.
 10. Let epoxy cure then the transducer is ready to operate. No water is now required in the bottom of the boat and gas and oil that is spilled inside of the boat will not degrade performance as it will if the transducer is placed only in water.
- CAUTION: Do not use the silicone seal or any soft adhesive to bond the transducer to the hull. This will reduce the sensitivity of the unit.

4. TROLLING MOTOR MOUNTING PROCEDURE

A "Trolling Motor Transducer" is designed to be mounted on the foot of the trolling motor with the aid of an adjustable clamp, included standard. Your trolling motor transducer will give excellent reading with no interference from the electric motor. Some boat manufacturers are now glassing in a second transducer beneath the front deck for thru the hull reading of the forward mounted depth sounder. This installation also serves a dual purpose in that a fisherman can run his big motor at idle speed and use his front depth sounder to scan for submerged stumps or obstacles. Such a practice can often prevent damage to props and lower units of the big outboard.

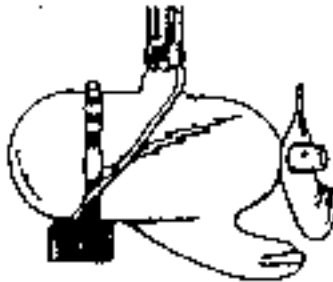

FIGURE 8

CAUTIONS

1. Occasionally the "eye" of your transducer may become dirty from storage or from contact with oils present in boats or marina environments. (Oil will cause the "eye" to lose the intimate contact with the water which is necessary for efficient operation.) The "eye" may be cleaned with liquid detergent.
2. Improper installation of the transducer can alter the efficiency and accuracy of the entire system.
3. If your boat or transducer is out of the water for a period of time, it may take a short period of time for the transducer to become thoroughly "wetted" when returned to the water. Also, re-entry may cause turbulence which will create air bubbles in the "eye" of the transducer. The bubbles will disappear in a short time or can be removed by rubbing the transducer "eye" with your fingers while the transducer is in the water.
4. If your instrument should fail to function, be sure to check all the electrical connections before removing the transducer or calling a serviceman.

5. Inspect your transducer cable and make sure that it has not been cut or damaged to the point where it will affect the performance of the transducer. A slight nick or cut, exposing the outer cable, can be repaired by wrapping with electrical tape. A transducer can be damaged if the inner cable and outer cable are allowed to make contact. Such a problem can sometimes be corrected by properly splicing the coaxial cable. This should only be attempted by a qualified service technician.
6. If your LCR is not working properly and you suspect the problem might be in your transducer, we would recommend you borrow a unit from a friend and try it on your boat. If the symptoms are the same, you can almost be certain that the problem is in the transducer.

INSTALLING THE LCR

The LCR should be mounted on a flat, solid surface for maximum stability. The low profile swivel mount has four holes drilled in the base. It is recommended that all four holes be used.

Position the swivel base and drill four 1/4" diameter holes. Note: The LCR hole pattern is the same as for all Humminbird flasher units. Use hardware provided to mount this base to the boat.

Next place the gimbal bracket on the swivel base and attach with four small machine screws, provided.

Place the LCR in the gimbal mount and make certain the rubber washers provided are placed between the unit and the gimbal bracket. Important: Note which side of the gimbal faces forward. (Slots on gimbal bracket go towards rear). Also, rubber washer must be located between the unit and the gimbal bracket.

Install the mounting knobs and tighten snugly. The unit can now be swiveled and tilted to any desired position.

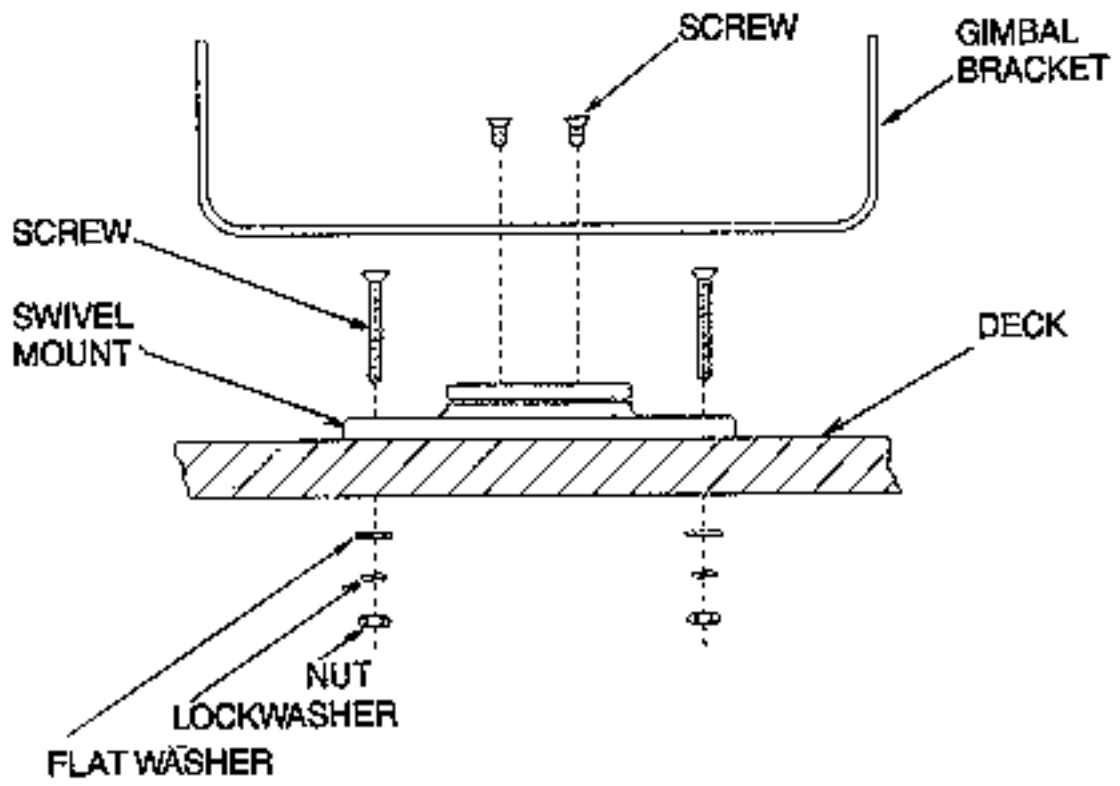

FIGURE 9

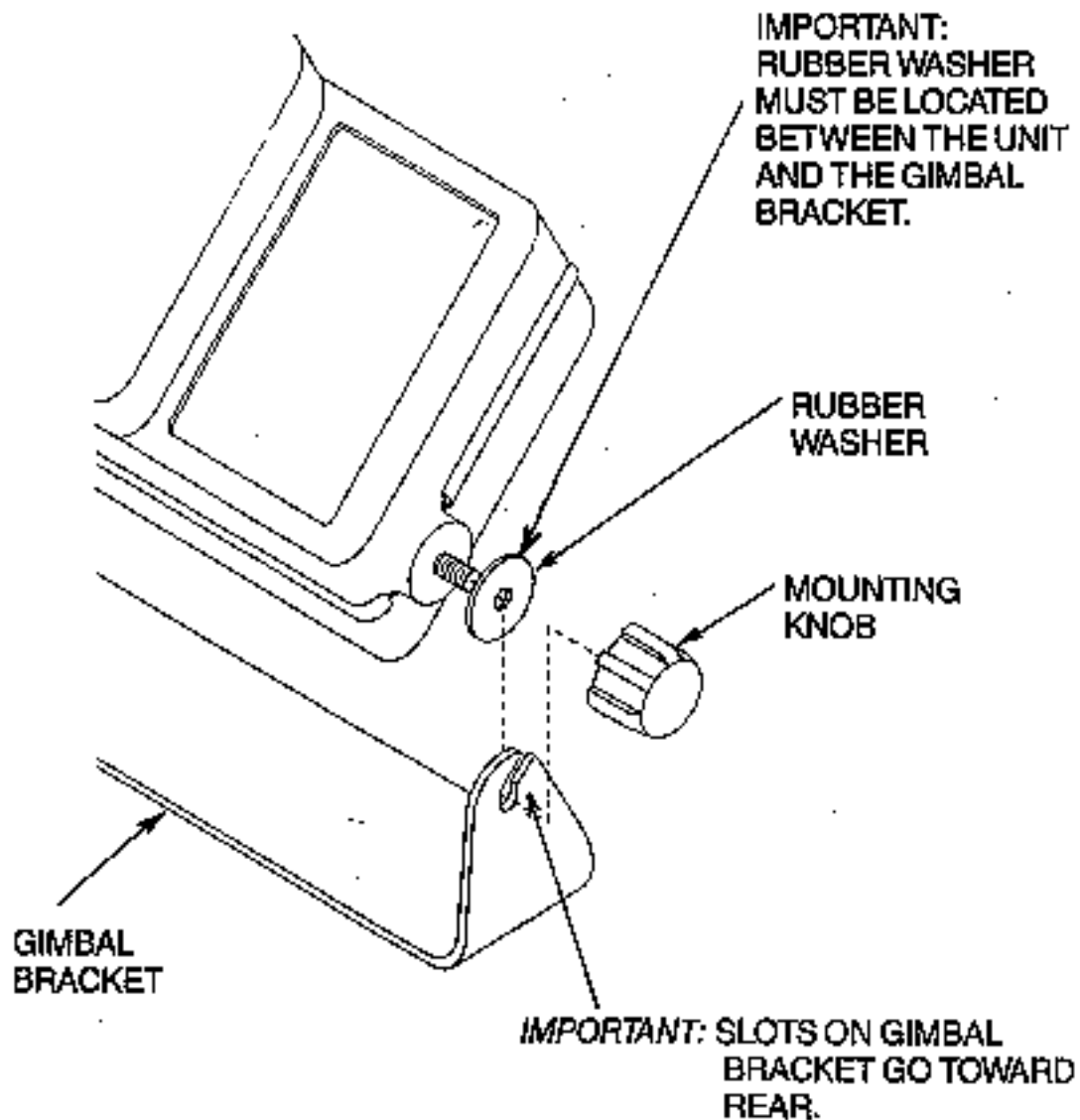

FIGURE 10

OTHER MOUNTING OPTIONS

1. The LCR gimbal bracket can also be mounted on the SM-4, quick disconnect swivel mount.
2. The LCR gimbal bracket can also be mounted directly to the dash without the swivel mount, however, this method is not recommended since the unit cannot be rotated.

INSTALLING THE CABLES

Your LCR comes equipped with Humminbird's new Angle-Lock power and transducer connectors. The power connector is identified with the letter P on the back of the plug.

It plugs into the outlet on the back of the unit marked "Power". The transducer connector is identified with the letter T and plugs into the outlet on the back of the unit marked "Transducer". Note: An adapter (AD-4) is available to allow use of an old waterproof (BNC) transducer with the LCR, but be sure that the transducer is a 16degree. A 32 degree transducer cannot be used. A 1 1/8" hole must be drilled to pull through the transducer connector. After drilling the hole, pull the transducer connector up through the hole. If you are installing two units, both transducer connectors can be pulled through this 1 1/8" inch hole. Next, push the power cable wires down through the hole. A hole cover has been provided which will dress and hold the wires. Install the hole cover after determining the necessary wire length from the hole. The power cable has a red lead to the positive (+) post and the black lead to the negative (-) post. Install a 1 amp fuse between the red cable and positive post of your 12-volt battery. If a fuse panel is available, we recommend wiring the power cable into the fuse panel. Note: The LCR must be fused separately from any other accessory. Your Angle-Lock connectors can only be plugged in one way. Position the connector so the letter P or T can be read and the 90 degree bend is pointed downward. Push the connector in as far as it will go. Turn the positive locking ring as far as it will go clockwise until you feel it lock. locking ring as far as it will go clockwise until you feel it lock. Your connector is now locked into place. Note: For easy access to the connectors, simply loosen the mounting knobs and tilt your LCR forward. The connectors are now in full view and easy to plug or unplug.

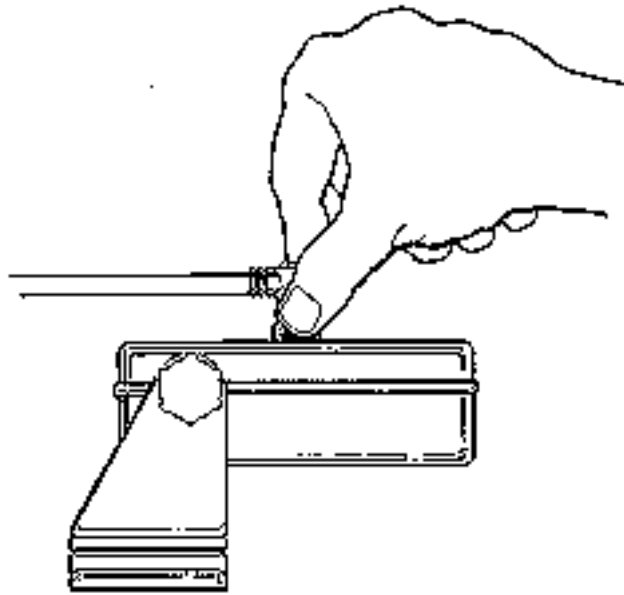

TESTING YOUR UNIT AND TRANSDUCER INSTALLATION

After installing the unit, transducer, and cables, you are ready to test the installation. You should put your boat in the water to test the unit because the transducer cannot transmit and receive properly through air.

INITIAL UNIT TESTING

With your boat in the water at idle or at a very slow speed, turn your LCR on by pushing the "Power" button. The LCR's computer will automatically adjust the sensitivity and depth range so

that in about one second you will see images appear on the right side of the display and moving to the left.

TROUBLE SHOOTING: If nothing happens when the “Power” button is pushed, check your electrical connections and fuse. Also check that the red wire on the power cable is connected to the positive battery terminal and that the black wire is connected to the negative battery terminal. If these wires are reversed it will not damage the LCR. It is normal if when reversing the boat, the bottom return is lost, since air from the prop is being forced under the transducer. Remember the transducer cannot transmit through air.

TROUBLE SHOOTING: If the display comes on when the “Power” button is pushed but no bottom information is seen, check that the transducer connector is securely locked to the rear of the LCR. Also insure that the transducer is completely submerged. A transducer cannot work properly in air or through air bubbles in the water.

TROUBLE SHOOTING: In very shallow water, the bottom reading might have gaps of the range might change to a deeper range. This is normal in about two feet or less. The automatic mode cannot “lock” onto the bottom in very shallow water.

TROUBLE SHOOTING: If the LCR comes on without pressing the “Power” button, carefully inspect the transducer cable. This condition will be seen if the outer jacket of the cable has been cut and is touching any metal piece of the boat.

TRANSDUCER INSTALLATION TEST

After verifying that your LCR is working properly, you are ready to increase boat speed to test the transducer installation. As you increase boat speed the LCR should give a continuous bottom return. With a proper transducer installation your LCR will perform at speeds up to 75 miles per hour.

TROUBLE SHOOTING: If at high speeds the bottom return is not continuous or there are gaps in the bottom, then the transducer installation or location is such that air is going under the transducer face. Refer back to the transducer mounting procedure for adjustments or for other mounting options.

TROUBLE SHOOTING: If at high speed and high sensitivity setting the display begins to blacken, then cavitation noise from the propeller is being received by the transducer. The transducer should be moved away from the prop or to another location to reduce the cavitation noise.

TROUBLE SHOOTING: If when making a hard turn, the bottom reading is lost, it is the result of the transducer coming out of the water during the turn.

OPERATIONAL INSTRUCTIONS

The LCR4x6, while being a technically advanced, state-of-the-art depth sounder. Is probably the easiest unit to operate. Only 7 buttons control all of the unit’s features.



1. This button turns the unit on and off. Pressing it once turns the unit on. Pressing it again turns the unit off.
2. This button stops or freezes the display. Pressing it once stops the display. Pressing it again starts it back up.
3. This button turns the night light on and off. Pressing it once turns the light on. Pressing it again turns it off.
4. This button allows you to select any of eight functions for easy adjustment right on the unit’s screen.
5. This button allows you to move a function up or increase it.
6. This button allows you to move a function down or decrease it. It is also the “store” key for screen memory.
7. This button allows you to turn a feature on and off.

SELECTING AND OPERATING THE FUNCTIONS

Pressing the button will result in one of eight different menus of the LCR4x6 functions to be displayed on the screen. Each time the button is pressed a different menu will appear. After the eighth different menu is displayed, the first menu will be displayed again. Unless the , or button is pressed, no function will be changed. If no button is pressed after about three seconds, the menu will disappear. Pressing the button again will cause the last menu to be displayed again or holding it down will cause the menu to be displayed as long as it is held down. If no function is being displayed pressing the , , or key will cause the last menu to be displayed, assuming that button is active, that is, that it can change the function.



FIGURE 14

-  To increase display speed
-  To decrease display speed
-  Not used

THINGS TO KNOW ABOUT DISPLAY SPEED

- A. There are eight display speeds, indicated by the eight bars on the display.
- B. When the LCR is turned on the unit will be advancing at the maximum display speed.
- C. When a maximum or minimum speed is reached, a chirping sound will be heard.

1. AUTOMATIC AND MANUAL OPERATION AND SENSITIVITY ADJUSTMENT



ADJUSTMENT



FIGURE 15

- Ⓐ To increase sensitivity setting in Manual Mode.
- Ⓑ To decrease sensitivity setting in Manual Mode.
- Ⓒ To turn automatic operation off (Manual Mode) and back on again.

THINGS TO KNOW ABOUT AUTOMATIC AND MANUAL OPERATION

- A. When the LCR is turned on the unit is in the automatic mode. This is indicated on the menu and in the lower left area of the screen. In the Automatic Mode the sensitivity is continuously adjusted automatically, the correct depth range is automatically selected and the area below the bottom return is blackened out making the bottom easy to see.
- B. There are 16 levels of sensitivity adjustment, indicated by the bars on the menu and in the lower left area of the display.
- C. Pressing either the , , or the  button will put the LCR in the Manual Mode.
- D. In the Manual Mode the digital bottom reading goes off and the automatic range change is off. Also the area below the bottom is no longer blacked out, therefore a second return or double echo can be displayed if desired (see Figure 16). Also, the hardness of the bottom can sometimes be determined by the thickness of the second bottom return. For example, a hard or rock bottom will give a wider return as compared to a soft or muddy bottom.

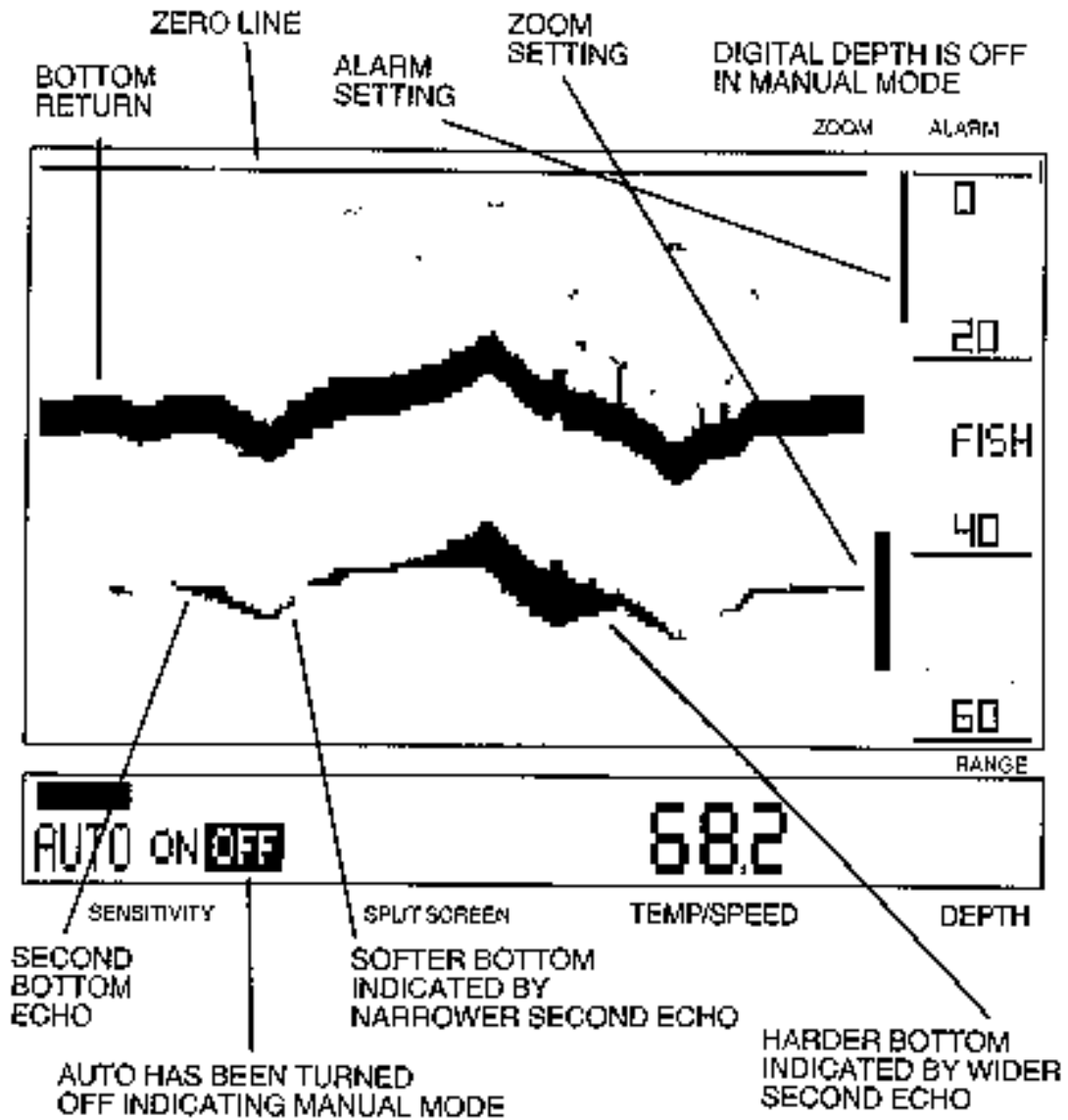

FIGURE 16

- E. In the Manual Mode it is possible to have the sensitivity set too high such that reflection from suspended matter or air bubbles will begin to black out the display.

3. DEPTH RANGE



FIGURE 17

☞ To increase depth range

THINGS TO KNOW ABOUT DEPTH RANGE

- A. In the automatic mode the proper depth range is found as soon as the unit is turned on.
- B. As you move into deeper water and the bottom goes off the screen, the next deeper depth range will automatically be activated. Also, as water becomes shallower reaching the top one third of the screen the depth range will automatically change to the next shallower scale.
- C. As the depth range changes, the scales to the right of the display will also change indicating the maximum depth of that range and also intermediate depths at one-third and two-thirds of the full scale.
- D. The LVR4x6 has six depth ranges: 0-15 feet, 0-30 feet, 0-69 feet, 0-120 feet, 0-180 feet, and 0-240 feet. You may manually change the depth range by pressing the , or buttons.
- E. In the Automatic Mode, if you attempt to change to a depth range which is less than the actual bottom depth, the computer will automatically change the depth range back to the proper position. For example, if you are in 40 feet of water and you change the depth range to 30 feet, the computer will automatically change back to the 60 foot range.
- F. The button, while on the depth range menu, will turn the Automatic Mode on and off. It has the same function as the button used on the sensitivity menu.
- G. In the Manual Mode the automatic range change is not active. This means you must manually set the depth range by pressing the or buttons.





4. BOTTOM ALARM



FIGURE 18

- ⓘ To adjust the bottom alarm setting up (more shallow)
- Ⓜ To adjust the bottom alarm setting down (deeper)
- Ⓜ To turn the bottom alarm on and off

THINGS TO KNOW ABOUT BOTTOM ALARM

- A. The alarm setting is shown digitally (in numbers) on the menu and graphically (by the vertical bar) on the right side of the display. It is set at 5 feet when the unit is first turned on.
- B. When the bottom alarm is turned off it is indicated on the menu and the vertical bar disappears on the right side of the display.
- C. Pressing the  or  button once will change the setting by one division. Holding either button down will cause the setting to change rapidly. You will notice that the increments of change will vary depending on the depth range. For example, on the 0 to 15 foot range the setting will change about 3 inches each time the  or  button is pressed while on the 0 to 240 foot range increment is 4 feet.
- D. The alarm setting may be set from 1 foot to 240 feet.
- E. In the Automatic Mode the Bottom Alarm will sound a continuous Alarm when the bottom is equal to or less than the setting. Fish will not trigger the bottom alarm.
- F. In the Manual Mode wither the bottom or fish can trigger the alarm. If the bottom depth becomes equal to or less than the alarm setting, a continuous Alarm will sound. If a fish enters the Alarm range, a short quick Alarm will sound.
- G. If the Bottom Alarm is turned off and then back on again before the unit is turned off, it will be set at the previous setting.

5. FISH ALARM

FISH ALARM

ON OFF



FIGURE 19

- ⊖ Not used
- ⊖ Not Used
- ⊖ To turn the fish alarm on and off

THINGS TO KNOW ABOUT FISH ALARM

- A. The Fish Alarm will give a short alarm sound when a return is detected between the boat and 3 inches from the bottom. It will not alarm on the bottom.
- B. When the Fish Alarm is on it is indicated on the menu and also on the right side of the display by the word "FISH".
- C. The Fish Alarm is operational only while the LCR is in the Automatic Mode. See paragraph F under Bottom Alarm for use of the alarm in the Manual Mode.
- D. The Fish Alarm may occasionally sound when no target is displayed. This can happen when a target is detected close to the bottom but is too close to be seen on the display because of the range selected. It can also happen when the display sweep speed is slow. Such that the target was detected but is gone by the time the display is updated.

6. ZOOM



FIGURE 20

- ⊖ To move the Zoom Cursor up
- ⊖ To move the Zoom Cursor down
- ⊖ To turn Zoom on and off

THINGS TO KNOW ABOUT ZOOM

- A. When Zoom is turned on, the screen will automatically split showing the full depth scale information on the right and the expanded view corresponding to the portion of the Zoom Cursor on the left (see Figure 2).
- B. When Zoom is turned on, it is indicated on the menu and at the lower middle part of the display.
- C. Pressing the or button once will move the Zoom Cursor one division. Holding the button down will cause the Cursor to move continuously.
- D. The size of the Zoom Range is automatically selected, depending on the depth range, as shown below with the display resolution for each range:

Depth Dot Range Equals	Zoom Range Size	Each
0-15, 0-30 Inch	7.5 Feet	$\frac{3}{4}$
0-60, 0-120 Inches	15 Feet	1 1/2
0-180, 0-240 Inches	30 Feet	3

- E. The exact depth of the top and bottom of the Zoom Range is displayed in the upper and lower left corners of the screen. As the Zoom Cursor is moved up and down these numbers will change to indicate the exact setting of the Zoom Range. These depth indicators will be very useful in pinpointing the exact depth of fish or structure.

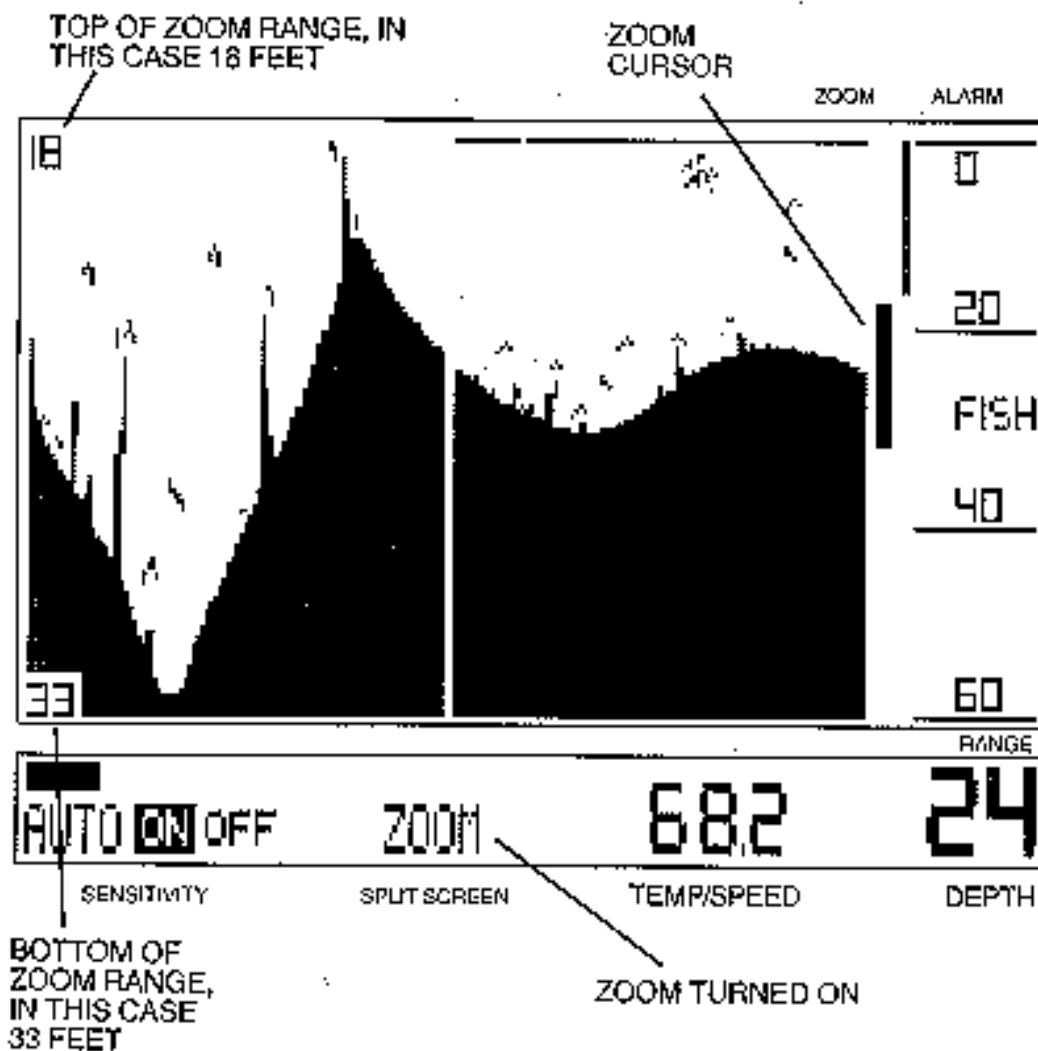

FIGURE 21

F. Zoom may be activated at any time. While learning to use Zoom it may be easier to press the button to freeze the display after positioning the Zoom Cursor. This will give you time to study the display. NOTE: If the display is stopped, the screen will not update (change) until the button is pressed again.

G. Remember that because of the LCR's Total Screen Update, even while you are using Zoom, no information is being lost. You can turn Zoom off, go to any depth range and see all the information just as if you had been on that depth range all along.

THINGS TO KNOW ABOUT BOTTOM LOCK

A. When Bottom Lock is turned on, the screen will automatically split showing the full depth scale information on the right and the expanded view from the bottom looking up on the left (See Figure 23).

- B. When Bottom Lock is turned on it is indicated on the menu and at the lower middle part of the display.
- C. Bottom Lock can only be used in the Automatic Mode.
- D. Bottom Lock will give an expanded view up from the bottom. The size of the expanded area is determined by the depth range, just as in Paragraph D under Zoom above. As the bottom depth changes, the Zoom Range will also change to maintain its position to the bottom.
- E. In Bottom Lock the bottom will always come onto the screen one third up from the bottom of the display (see figure 23). As the bottom depth changes the expanded view will also change so that the actual bottom contour can be seen.
- F. The actual depth of the Zoom Range is indicated in the upper and lower left portion of the screen. Since the Zoom Range always stays on the bottom, these depths will change as the bottom depth changes.
- G. Bottom Lock is a very valuable feature. If you are looking for bottom structure or fish close to the bottom. Bottom Lock is easiest to use on a relatively smooth bottom or at slow trolling speeds.

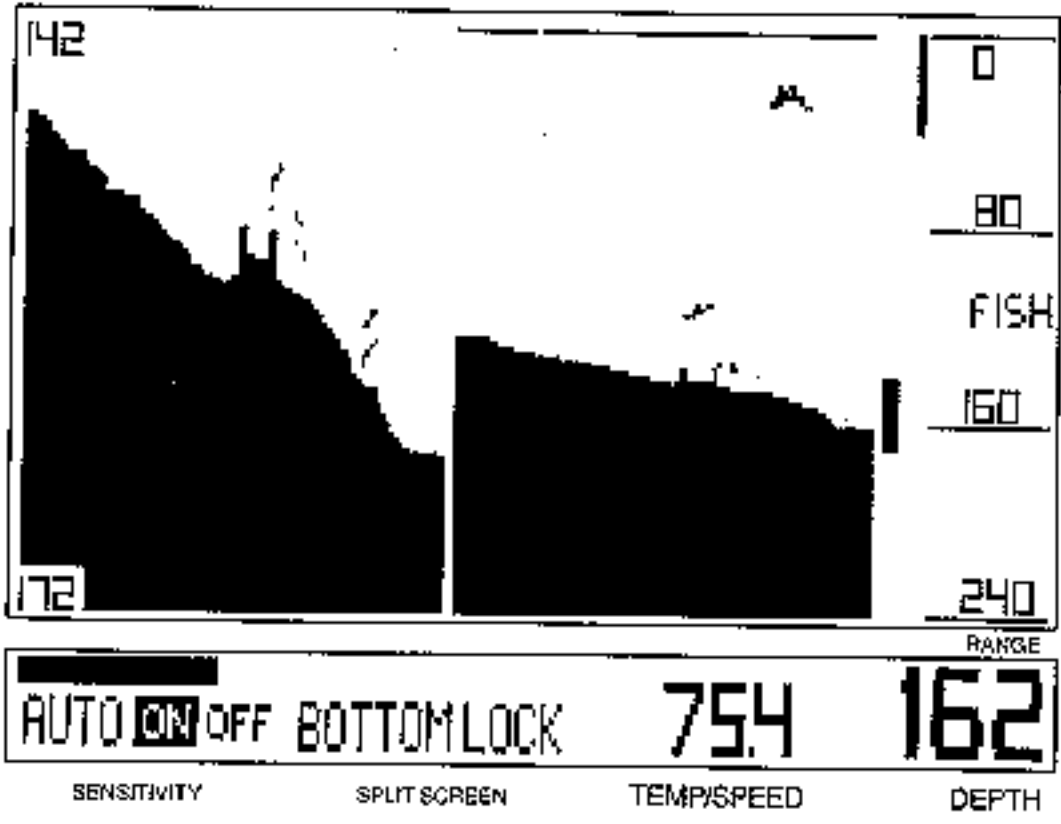

BOTTOM LOCK TURNED ON

FULL DEPTH RANGE INFORMATION, IN THIS CASE FROM 0 TO 240 FEET.

FIGURE 23

8. SCREEN MEMORY



FIGURE 24

- A. You can store 16 half screens in memory. Once stored, the Screen Memory will remain virtually forever. You can disconnect power from the LCR, store it over the Winter, bring it back out in the Spring and still be able to recall stored information.
- B. Use the to select one of 16 memory locations. When Screen Memory is turned on (indicated on the menu and at the lower middle of the display) the screen will automatically split to display the screen in memory on the left side and the full depth scale information on the right.
- C. If Zoom or Bottom Lock is on when Screen Memory is turned on, then the right half of the screen will show the Zoom or Bottom Lock information.
- D. To store a screen, first select a memory location number. Then with Screen Memory turned on, press the button. Any information previously stored in the memory location will be erased and replaced with the new information currently being displayed on the right half of the screen.
- E. Split Screen will allow you to compare a recalled screen (from memory) with the current reading. This will be useful in locating the same spot and comparing previous conditions to the present.

BUILT-IN SIMULATOR

Your LCD4x6 has a built-in simulator. This simulator will display a typical underwater scene which can be used for demonstration or for learning how to use and understand your unit.

To activate the simulator, the unit must first be turned off. Next, push in the button for one to two seconds, until you hear the chirping sound. Then release the button and the simulated display will begin.

In the simulation mode all buttons and features can be used. It should be noted, however, that increasing or decreasing the sensitivity setting will not affect the information being displayed.

CARING FOR YOUR LCR:

Since your Humminbird LCR is completely waterproof, it can be cleaned with soap and water or hosed off after salt water use with no fear of damage to the unit or its electronics. When cleaning the lens, it is suggested you use a chamois cloth and a non-abrasive cleaner such as Windex. Do not wipe while dirt or other gritty material is on the lens. Care should be exercised to avoid scratching the lens. Keep chemicals such as bug repellent, ammonia or gasoline away from the LCR case and lens.

As with any electrical instrument, do not leave your LCR on the dash board or rear window area of the car. The sun can create extremely high temperatures which can damage the case and internal electrical components. During extended periods of non-use, such as Winter, you should store the LCR and other removable depth sounders in the house or garage. This will help prolong the good appearance and operation of these instruments.

LEARNING TO READ THE DISPLAY

The following illustrations show some typical displays with bottom, structure, and fish returns. These should help you in interpreting the information being displayed on your LCR4x6.

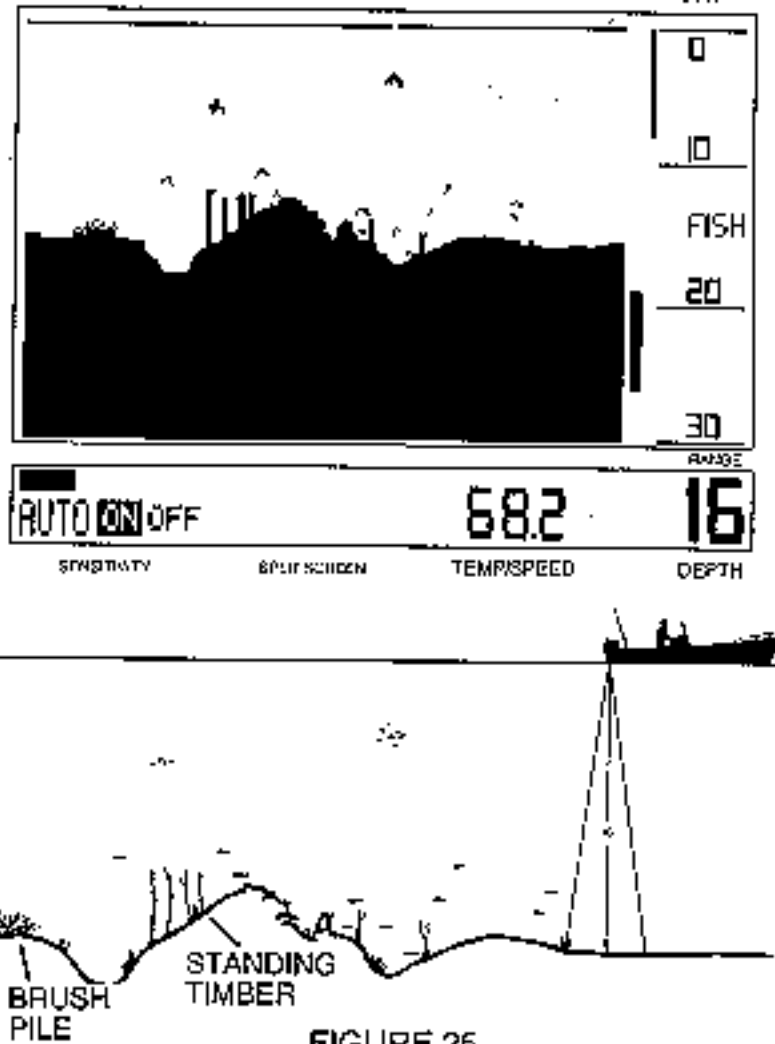

Brush and standing timber will appear as shown in the display above. The speed of the boat and display sweep speed will have a large effect on the way this information is displayed. For example, at a slow boat speed and a fast sweep speed the standing timber will appear wider. At a fast boat speed and a slow sweep speed some of the information will be missed.

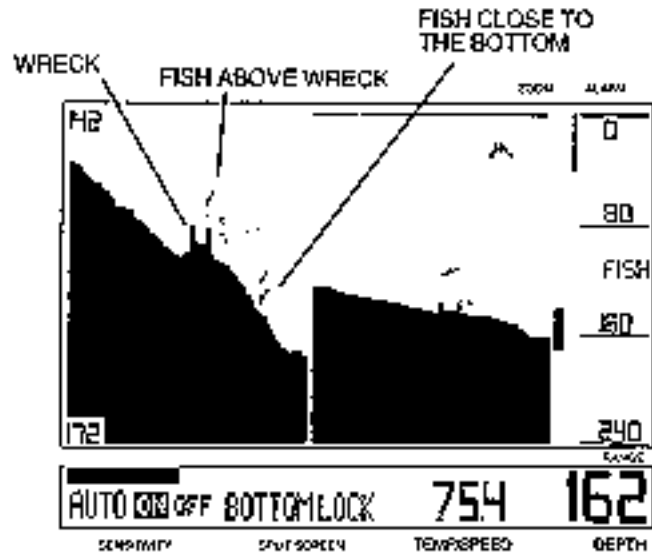

SPLIT SCREEN BOTTOM LOCK

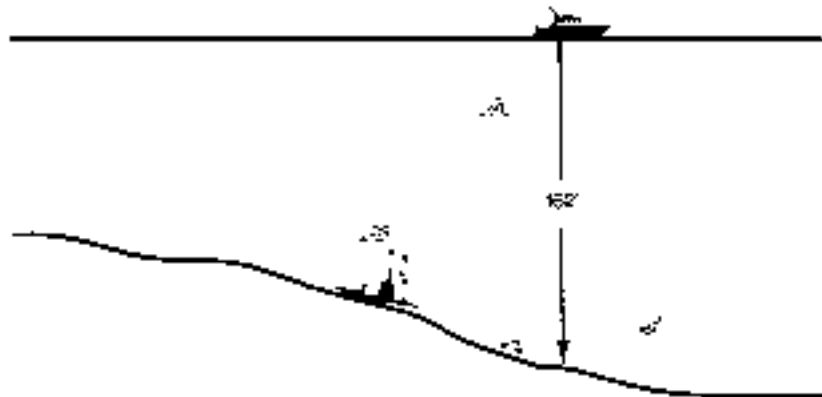

FIGURE 26

With Bottom Lock the wreck and the fish are clearly displayed on the left side of the screen which shows an expanded view 20 feet up from the bottom (screen is from 142 feet to 172 feet).

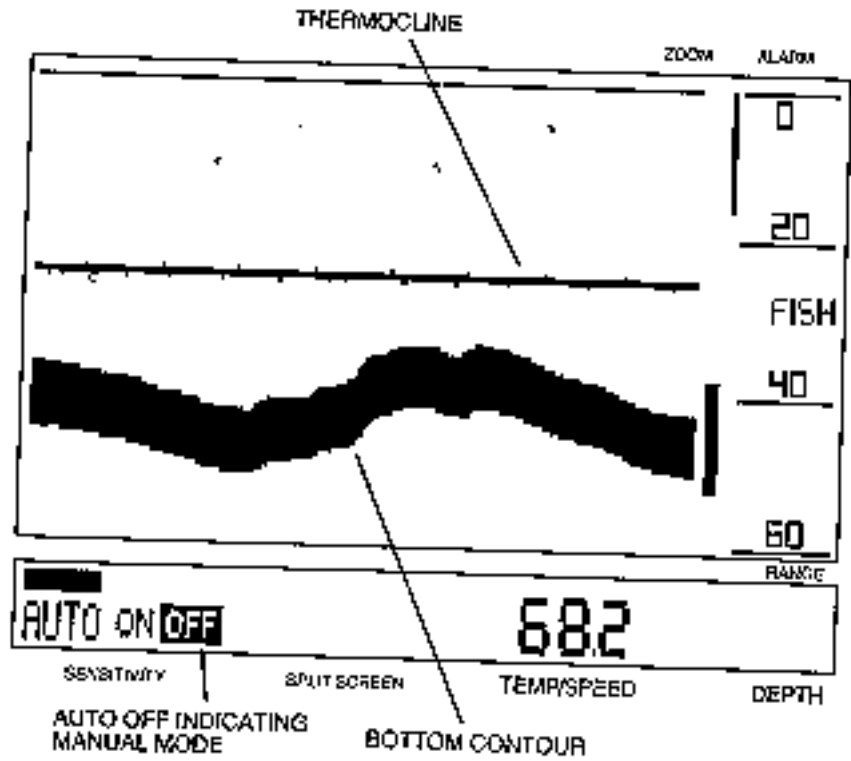

FIGURE 27

Thermocline is a temperature change at a certain depth in the water. In some conditions the sonar waves will actually reflect or bounce off this temperature change and therefore it will be displayed on the LCR as shown above. Normally a high sensitivity setting is required to show the thermocline; therefore, if you want to see the thermocline go to the Manual Mode and increase the sensitivity level.

OPTIONAL TEMPERATURE AND SPEED GAUGES

Your LCR is designed to work well with an optional surface temperature gauge. Part Number TG-LCR, or an optional Trolling Speed Indicator, Part Number TSI-LCR. Fig. 26 illustrates the three basic parts of these gauges-the cable interconnection between the electronics and the LCR, the electronic housing, and the probe cable assembly.

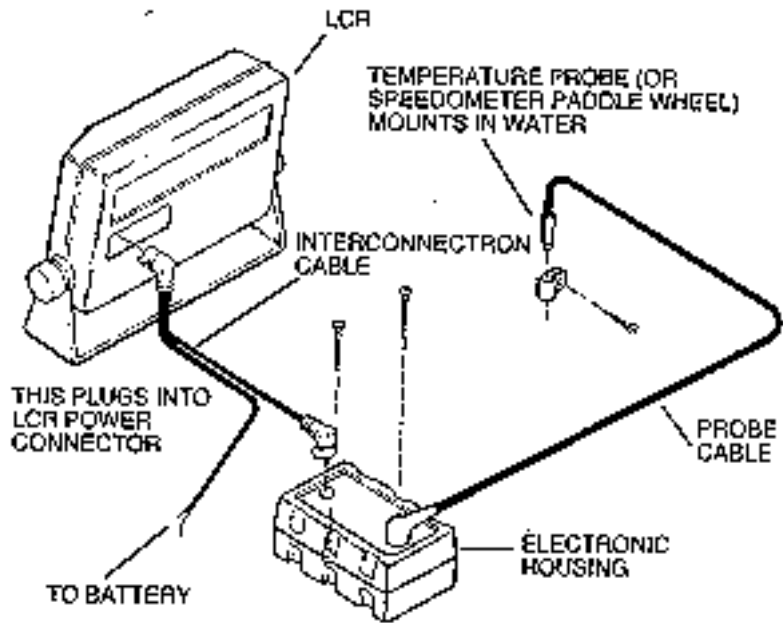

FIGURE 28

The surface temperature gauge is a valuable fishing and boating aid. It will measure water temperature in one-tenth of degrees and display the reading on the LCR screen. The probe and computer controlled electronics have been designed for an accurate indication and an extremely fast response time.

The Trolling Speed Indicator will give very accurate low speed readings, in tenths below 10 mph., unlike ordinary speedometers. An accurate trolling speed can make the difference in catching fish. The TSI-LCR also gives accurate high speed readings to 75 mph.

If you do not have a surface temperature gauge or a trolling speed indicator, see your LCR dealer or call the Humminbird Customer Service Department's Toll Free number Listed in the front of this manual. If you want both the TG-LCR and TSI-LCR an accessory switch is available to allow you to use both and select which one is being displayed on the screen.

SHOULD YOU NEED SERVICE

If, after reading the troubleshooting guide, you determine your Humminbird needs factory service, please attach the following information to the unit and send it to the address below.

Name (Please Print)

Street Address

City

State

Zip

Unit Purchase Date

Home Telephone

Work Telephone

Please describe briefly the problem:

Techsonic Industries, Inc.
Service Department
Three Humminbird Lane
Eufaula, AL 36027

The best products in the industry are backed by the best service policy in the industry. Even though you'll probably never need to take advantage of our incredible service guarantee, it's good to know that we back our units this well. We do it because you deserve the best.

One-Year Full Warranty

First year repairs on your unit will be made absolutely FREE (physical damage not included)

Limited Maximum Service Charge

After the warranty period,, a limited maximum service charge is the most you will pay for each repair (physical damage and missing parts not included).

Factory- Trained Technicians

All repair work is performed by factory- trained technicians to meet exacting factory specifications.

Strictest Factory Testing

Factory- serviced units go through the same rigorous quality- control inspections and full burn- in as new units.