

# NMEA 2000® Module Installation and Operations Manual

531989-1\_B

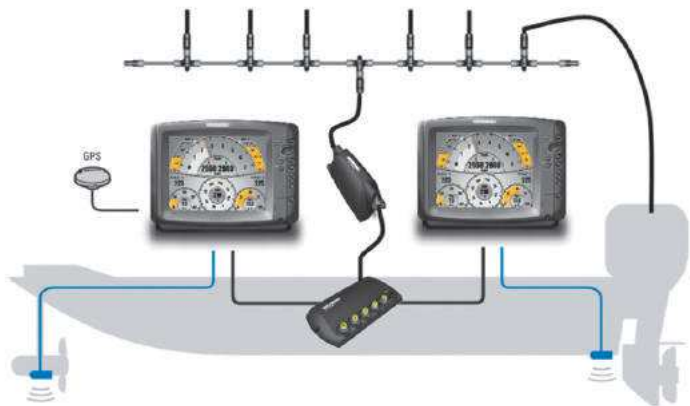

 **HUMMINBIRD**

## Accessory Manual

## Thank You!

---

Thank you for choosing Humminbird®, the #1 name in Fishfinders. Humminbird® has built its reputation by designing and manufacturing top-quality, thoroughly reliable marine equipment. Your Humminbird® accessory is designed for trouble-free use in even the harshest marine environment. In the unlikely event that your Humminbird® accessory does require repairs, we offer an exclusive Service Policy - free of charge during the first year after purchase, and available at a reasonable rate after the one-year period. For complete details, see the separate warranty card included with your accessory. We encourage you to read this operations manual carefully in order to get full benefit from all the features and applications of your Humminbird® product.

Contact our Customer Resource Center at **1-800-633-1468** or visit our Web site at **humminbird.com**.

**WARNING!** *This device should not be used as a navigational aid to prevent collision, grounding, boat damage, or personal injury. When the boat is moving, water depth may change too quickly to allow time for you to react. Always operate the boat at very slow speeds if you suspect shallow water or submerged objects.*

**WARNING!** *The electronic chart in your Humminbird® unit is an aid to navigation designed to facilitate the use of authorized government charts, not to replace them. Only official government charts and notices to mariners contain all of the current information needed for the safety of navigation, and the captain is responsible for their prudent use.*

**WARNING!** *Disassembly and repair of this electronic unit should only be performed by authorized service personnel. Any modification of the serial number or attempt to repair the original equipment or accessories by unauthorized individuals will void the warranty.*

**NOTE:** *Some features discussed in this manual require a separate purchase, and some features are only available on international models. Every effort has been made to clearly identify those features. Please read the manual carefully in order to understand the full capabilities of your model.*

**NOTE:** *To determine which Humminbird® models are compatible with the NMEA 2000® network, contact our Customer Resource at **1-800-633-1468** or visit our Web site at **humminbird.com**.*

**NOTE:** *Humminbird® recommends that the NMEA 2000® network be installed by a certified NMEA 2000® technician.*

**NOTE:** *Product specifications and features are subject to change without notice.*

---

**Environmental Compliance Statement:** It is the intention of Johnson Outdoors Marine Electronics, Inc. to be a responsible corporate citizen, operating in compliance with known and applicable environmental regulations, and a good neighbor in the communities where we make or sell our products.

**WEEE Directive:** EU Directive 2002/96/EC "Waste of Electrical and Electronic Equipment Directive (WEEE)" impacts most distributors, sellers, and manufacturers of consumer electronics in the European Union. The WEEE Directive requires the producer of consumer electronics to take responsibility for the management of waste from their products to achieve environmentally responsible disposal during the product life cycle.

WEEE compliance may not be required in your location for electrical & electronic equipment (EEE), nor may it be required for EEE designed and intended as fixed or temporary installation in transportation vehicles such as automobiles, aircraft, and boats. In some European Union member states, these vehicles are considered outside of the scope of the Directive, and EEE for those applications can be considered excluded from the WEEE Directive requirement.



This symbol (WEEE wheeie bin) on product indicates the product must not be disposed of with other household refuse. It must be disposed of and collected for recycling and recovery of waste EEE. Johnson Outdoors Marine Electronics, Inc. will mark all EEE products in accordance with the WEEE Directive. It is our goal to comply in the collection, treatment, recovery, and environmentally sound disposal of those products; however, these requirements do vary within European Union member states. For more information about where you should dispose of your waste equipment for recycling and recovery and/or your European Union member state requirements, please contact your dealer or distributor from which your product was purchased.

**ROHS STATEMENT:** Product designed and intended as a fixed installation or part of a system in a vessel may be considered beyond the scope of Directive 2002/95/EC of the European Parliament and of the Council of 27 January 2003 on the restriction of the use of certain hazardous substances in electrical and electronic equipment.

**NOTE:** The NMEA accessory is compatible with many Humminbird® models, and every effort has been made to note the differences between the models and functions throughout this manual. The illustrations in this manual may look different than your display, but your model will operate in a similar way.

700 Series™, 800 Series™, 900 Series™, 1100 Series™, Humminbird®, InterLink™, and X-Press™ Menu are trademarked by or registered trademarks of Johnson Outdoors Marine Electronics, Inc.

Baekmuk Batang, Baekmuk Dotum, Baekmuk Gulim, and Baekmuk Headline are registered trademarks owned by Kim Jeong-Hwan.



NMEA 2000® is a registered trademark of the National Marine Electronics Association.

Portions of this software are copyright © 2012 The FreeType Project ([www.freetype.org](http://www.freetype.org)). All rights reserved.

© 2017 Johnson Outdoors Marine Electronics, Inc. All rights reserved.

# Table of Contents

---

<b>Introduction</b>	<b>1</b>
<b>Installation Preparation</b>	<b>2</b>
<b>Installation</b>	<b>3</b>
1. Determine the Mounting Location . . . . .	3
2. Install the NMEA 2000® Module . . . . .	4
<b>Cable Connection</b>	<b>5</b>
1. Determine the System Requirements . . . . .	5
2. Connect the Cables . . . . .	5
<b>Single Control Head Configuration</b>	<b>6</b>
1a. Connect to a 700 Series™ HD Control Head . . . . .	6
1b. Connect to an 800/900/1100 Series™ Control Head . . . . .	8
2. Connect the NMEA 2000® Module to the NMEA 2000® Network . . . . .	8
<b>Multiple Control Head Configuration</b>	<b>10</b>
1a. Connect a 700 Series™ HD Control Head to the Ethernet Switch . . . . .	12
1b. Connect an 800/900/1100 Series™ Control Head to the Ethernet Switch . . . . .	12
2. Connect the NMEA 2000® Module to the Ethernet Switch . . . . .	13
3. Connect the NMEA 2000® Module to the NMEA 2000® Network . . . . .	14
4. Connect the Ethernet Switch Power Cable to Power . . . . .	14
<b>Powering On</b>	<b>15</b>
<b>System Setup</b>	<b>16</b>
<b>NMEA 2000® Data Sources Setup</b>	<b>17</b>
1. Select NMEA 2000® Data Sources . . . . .	18
2. Set NMEA 2000® Data Offsets . . . . .	19
3. Select Units of Measurement for NMEA 2000® Readouts <i>(International models only)</i> . . . . .	19
<b>Network Menu Tab</b>	<b>21</b>
Customize the Unit Name . . . . .	22

# Table of Contents

---

<b>NMEA 2000® GPS Source Setup</b>	<b>23</b>
1. Select a NMEA 2000® GPS Source . . . . .	23
Confirm and Change a Lost NMEA 2000® GPS Source . . . . .	25
<b>Set Alarms</b>	<b>26</b>
1. Set NMEA2K Alarms . . . . .	26
Confirm an Alarm . . . . .	27
NMEA 2000® Alarms Table . . . . .	28
<b>Views</b>	<b>29</b>
NMEA2K Data Box View . . . . .	30
NMEA2K Gauge View . . . . .	31
NMEA2K One Engine View . . . . .	32
NMEA2K Two Engine View . . . . .	33
Display NMEA2K Views. . . . .	34
Select Readouts for NMEA2K Views . . . . .	35
<b>Troubleshooting</b>	<b>37</b>
Fishing System Doesn't Power Up. . . . .	37
Fishing System Defaults to Simulator with a Transducer Attached. . . . .	37
<b>Specifications</b>	<b>38</b>
NMEA 2000® Sentences Table . . . . .	38
NMEA 2000® Module Configurations . . . . .	39
<b>Contact Humminbird®</b>	<b>41</b>

***NOTE:** Entries in this Table of Contents which list (International models only) are only available on products sold outside of the U.S. by our authorized international distributors. To obtain a list of authorized international distributors, please visit our Web site at [humminbird.com](http://humminbird.com) or contact our Customer Resource Center at (334) 687-6613.*

# Introduction

---

This manual will guide you through the following installation and network setup instructions for the NMEA 2000® Module:

- Installing the NMEA 2000® Module
- Connecting the Cables
- Powering On
- Configuring the Humminbird® NMEA 2000® Network
- Setting Alarms
- Accessing Views

# Installation Preparation

Following are instructions for the installation of this accessory. Before you start installation, we encourage you to read these instructions carefully in order to get the full benefit from your Humminbird® accessory.

**It is important to note that the NMEA 2000® Module installation and network setup have the following requirements:**

<b>Update Software</b>	Your model may require a software update to connect to the NMEA 2000® network. To download the latest software update, log on to your account at <a href="http://humminbird.com">humminbird.com</a> . For assistance, call our Customer Resource Center at <b>1-800-633-1468</b> .
<b>Confirm all Humminbird® products are properly installed and connected.</b>	Confirm all Humminbird® control heads and sources (GPS, transducers, temp/speed accessories, etc.) are properly installed and connected. <b>NOTE:</b> Consult your control head installation guide and accessory guides for details.
<b>Confirm the NMEA 2000® network is properly installed and connected to power.</b>	Confirm all NMEA 2000® devices (NMEA 2000® Backbone, T-connectors, Drop Cable, etc.) are properly installed and connected to power. See the NMEA (National Marine Electronics Association) Web site at <a href="http://nmea.org">nmea.org</a> for information about manufacturers of NMEA 2000® certified products and proper NMEA 2000® network installation.
<b>Purchase Connection Accessories</b>	Depending on your Humminbird® model and network configuration, you may need to purchase additional accessories to connect your NMEA 2000® Module to your NMEA 2000® network. See <b>Cable Connection</b> for more information. <ul style="list-style-type: none"><li>• AS EC [length]E Ethernet Cables (available in a variety of lengths)</li><li>• AS EC ODE Ethernet Adapter Cable</li><li>• AS ETH 5PS Ethernet Switch</li></ul> <b>NOTE:</b> To purchase Ethernet Accessory Cables, extension cables, or the Ethernet Switch, visit our Web site at <a href="http://humminbird.com">humminbird.com</a> or call our Customer Resource Center at <b>1-800-633-1468</b> for details.
<b>NMEA 2000® Module Installation Configurations</b>	Only one Humminbird® NMEA 2000® Module can be connected to a NMEA 2000® network. Review the supported and unsupported configuration examples in the <b>Specifications</b> section of this manual for more information.
<b>Supplies</b>	In addition to the hardware supplied with your installation kit, you will need a powered hand drill, a 9/64" drill bit, a Phillips screwdriver, a level, and a pencil.

# Installation

---

The NMEA 2000® Module is designed to mount on any flat, level surface on your boat. Use the instructions in this section to install the NMEA 2000® Module on your boat.

## 1. Determine the Mounting Location

---

Prior to installation, you must first determine where to mount the NMEA 2000® Module.

1. Use a level to locate a suitable, flat area to mount the NMEA 2000® Module.
2. See the configuration examples under ***Cable Connection***. Test run the cables to the NMEA 2000® Module based on the configuration you will use. Determine whether you will need to purchase additional Ethernet Connect Cables or extension cables.



## 2. Install the NMEA 2000® Module

Once you have determined the mounting location, perform the following procedures to install the NMEA 2000® Module on your boat.

1. Set the NMEA 2000® Module in place on the mounting surface. Mark the two mounting screw locations with a pencil.
2. Set the NMEA 2000® Module aside, and drill the two mounting holes using a 9/64" drill bit.

**NOTE:** On fiberglass hulls, it is best to use progressively larger drill bits to reduce the chance of chipping or flaking the outer coating.

**NOTE:** If the mounting surface is thin or made of lightweight material, you may need to add reinforcing material below the mounting surface in order to support the NMEA 2000® Module.

3. Place the NMEA 2000® Module on the mounting surface and align the screw holes with the drilled mounting holes. Insert the two #8 screws (included) through the screw holes and into the drilled mounting holes. Hand-tighten using a Phillips screwdriver. **Hand-tighten only!**

**NOTE:** Apply marine-grade silicone caulk or sealant (separate purchase required) to both screws and drilled holes as needed to protect your boat from water damage.

Installing the NMEA 2000® Module

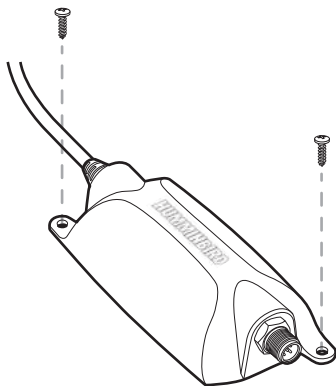

# Cable Connection

---

Use the instructions in this section to install the cables that connect the NMEA 2000® Module to your NMEA 2000® network.

**NOTE:** *The NMEA 2000® Module does not provide power for the NMEA 2000® network.*

**NOTE:** *Only one NMEA 2000® Module can be connected to the NMEA 2000® network at one time. See **Specifications: NMEA 2000® Module Configurations** for more information.*

## 1. Determine the System Requirements

---

Before connecting your NMEA 2000® Module to the NMEA 2000® network, you must first determine the correct cable requirements for your Humminbird® model(s).

See the cable connection information for your network configuration as follows:

- To connect the NMEA 2000® Module to one control head, see **Single Control Head Configuration**.
- To connect the NMEA 2000® Module to multiple control heads, see **Multiple Control Head Configuration**.

**NOTE:** *You may need to consult your control head installation guide for details.*

## 2. Connect the Cables

---

Once you have determined your cable requirements, proceed to the section for that configuration.

**NOTE:** *Confirm all control heads are powered off before proceeding with the installation.*

**NOTE:** *The connectors are keyed to prevent incorrect installation, so be careful not to force the connectors.*

# Single Control Head Configuration

Use the instructions in this section to connect the NMEA 2000® Module to one control head. Proceed to the section that matches your Humminbird® model.

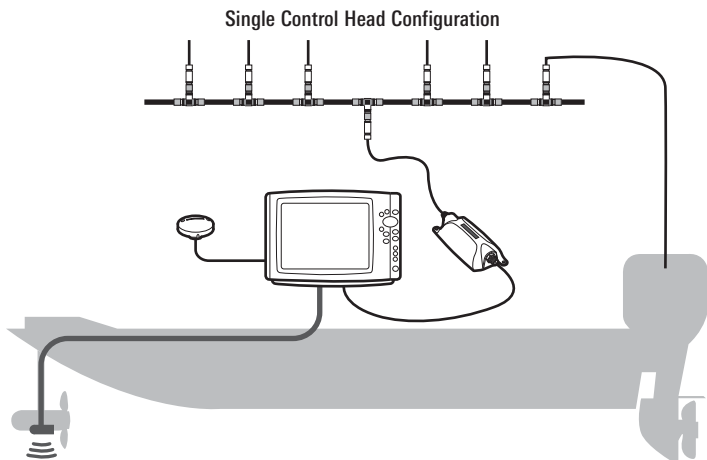

## 1a. Connect to a 700 Series™ HD Control Head

To connect the NMEA 2000® Module to a 700 Series™ HD control head, you will need to use an AS EC QDE Ethernet Adapter Cable.

1. Insert the AS EC QDE Ethernet cable connector into the Ethernet slot on the 700 Series™ HD Quick Disconnect Mount Cable Collector.

### 700 Series™ HD Quick Disconnect Mount Cable Collector

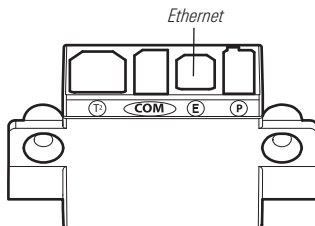

**NOTE:** The 700 Series™ HD control head uses a cable collector for the Quick Disconnect Mount and the In-Dash Mount. See your control head installation guide for details.

## Connecting the NMEA 2000® Module to a 700 Series™ HD Unit

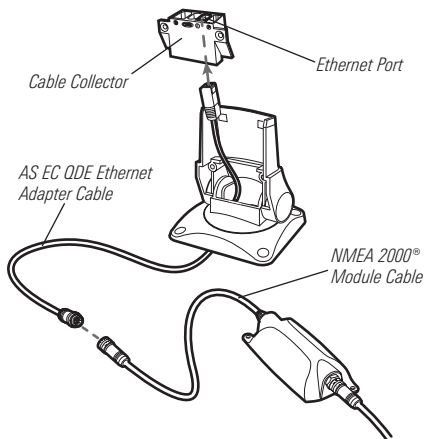

2. Connect the AS EC QDE cable connector to the NMEA 2000® Module cable.
3. Hand-tighten the screw nut to secure the connection.
4. After completing these steps, skip ahead to procedure two, **Connect the NMEA 2000® Module to the NMEA 2000® Network.**

### Hand-Tightening the Screw Nut

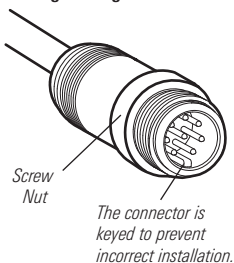

## 1b. Connect to an 800/900/1100 Series™ Control Head

Control heads with built-in Ethernet ports (800, 900, and 1100 Series™ units only) can be connected to the NMEA 2000® Module directly.

1. Insert the NMEA 2000® Module cable connector into the Ethernet port on the back of the control head.
2. Hand-tighten the screw nut to secure the connection.

### Connecting the NMEA 2000® Module to an 1100 Series™ Control Head

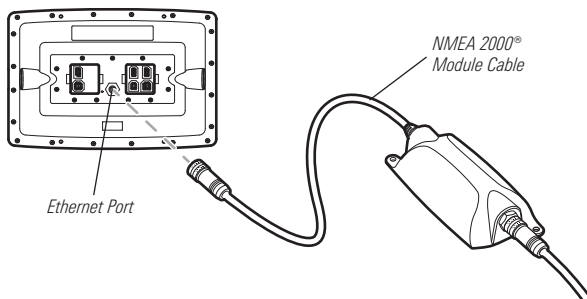

## 2. Connect the NMEA 2000® Module to the NMEA 2000® Network

To connect the NMEA 2000® Module to the NMEA 2000® network, you must install a NMEA 2000® Drop Cable.

1. Plug the NMEA 2000® Drop cable connector into the NMEA 2000® Module connector port. Hand-tighten the screw nut to secure the connection.
2. Connect the NMEA 2000® Drop cable to a T-connector on your NMEA 2000® network (see the illustration *Connecting the NMEA 2000® Module to an Ethernet Switch*).

## Connecting the NMEA 2000® Drop Cable to the NMEA 2000® Module

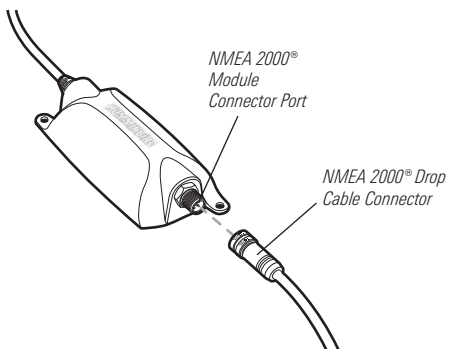

## Multiple Control Head Configuration

To connect the NMEA 2000® Module to more than one control head, you will need to install a Humminbird® Ethernet Switch. The control heads and the NMEA 2000® Module plug into the Ethernet Switch.

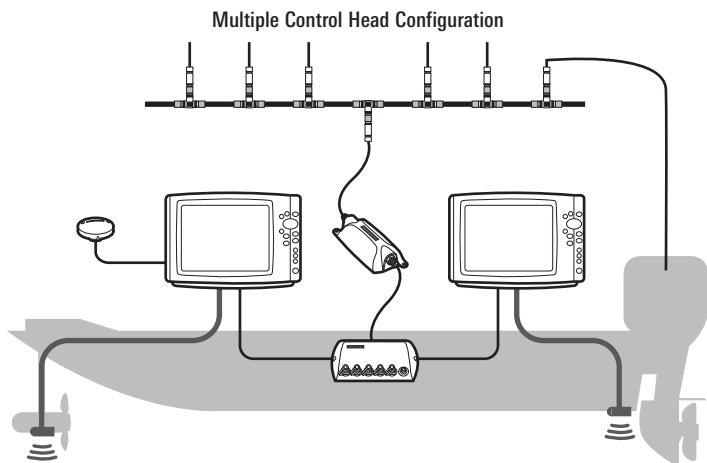

**NOTE:** Up to four Humminbird® control heads can be connected to the NMEA 2000® Network via Ethernet Switch at one time.

## Multiple Control Head Installation Overview

Before proceeding with this installation, review your Ethernet Switch installation guide to understand how to install the Ethernet Switch and connect power.

To install the NMEA 2000® Module using the Humminbird® Ethernet Switch, you must perform the following procedures:

- Connect the control head(s) to the Ethernet Switch. See the section that matches your Humminbird® control head model.
- Connect the NMEA 2000® Module to the Ethernet Switch.
- Connect the NMEA 2000® Module to the NMEA 2000® Network.
- Connect the Ethernet Switch power cable to a power source.

### Connecting the NMEA 2000® Module to an Ethernet Switch

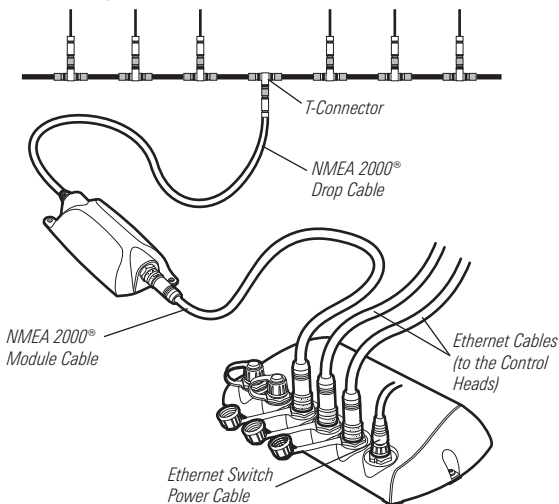



## 1a. Connect a 700 Series™ HD Control Head to the Ethernet Switch

---

To connect a 700 Series™ HD control head to the Ethernet Switch, you will need to use an AS EC QDE Ethernet Adapter Cable.

1. Insert the AS EC QDE Ethernet cable connector into the Ethernet slot on the 700 Series™ Quick Disconnect Mount Cable Collector.

### 700 Series™ HD Quick Disconnect Mount Cable Collector

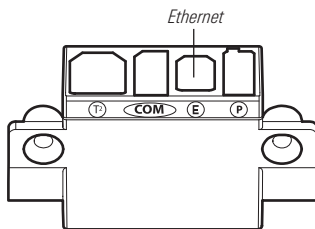

**NOTE:** The 700 Series™ control head uses a cable collector for the Quick Disconnect Mount and the In-Dash Mount. See your control head installation guide for details.

2. Unscrew an Ethernet port cover from the Ethernet Switch.
3. Plug the AS EC QDE Ethernet cable connector into the port. Hand-tighten the screw nut to secure the connection.

## 1b. Connect an 800/900/1100 Series™ Control Head to the Ethernet Switch

---

To connect an 800/900/1100 Series™ control head to the Ethernet Switch, you will need to use a Humminbird® Ethernet Accessory Cable.

1. Insert the Ethernet cable connector into the Ethernet port on the back of the control head. Hand-tighten the screw nut to secure the connection.
2. Unscrew an Ethernet port cover from the Ethernet Switch.
3. Plug the Ethernet cable connector into the port. Hand-tighten the screw nut to secure the connection.

## Connecting the Ethernet Accessory Cable to an 1100 Series™ Control Head

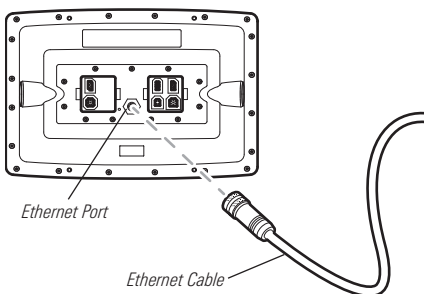

## 2. Connect the NMEA 2000® Module to the Ethernet Switch

1. Unscrew an Ethernet port cover from the Ethernet Switch.
2. Plug the NMEA 2000® Module cable connector into the port. Hand-tighten the screw nut to secure the connection.

### Connecting Ethernet Cable Connectors to the Ethernet Switch

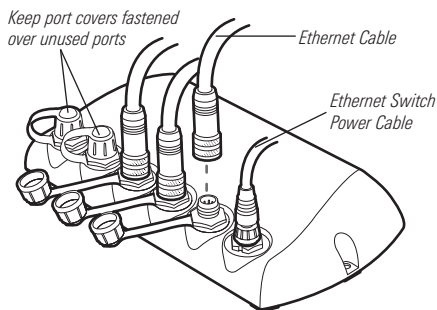

**NOTE:** See the illustration, *Connecting the NMEA 2000® Module to an Ethernet Switch*, for more details.

### **3. Connect the NMEA 2000® Module to the NMEA 2000® Network**

---

To connect the NMEA 2000® Module to the NMEA 2000® network, you must install a NMEA 2000® Drop Cable.

1. Plug the NMEA 2000® Drop cable connector into the NMEA 2000® Module connector port. Hand-tighten the screw nut to secure the connection.
2. Connect the NMEA 2000® Drop cable to a T-connector on your NMEA 2000® network (see the illustration *Connecting the NMEA 2000® Module to an Ethernet Switch*).

#### **Connecting the NMEA 2000® Drop Cable to the NMEA 2000® Module**

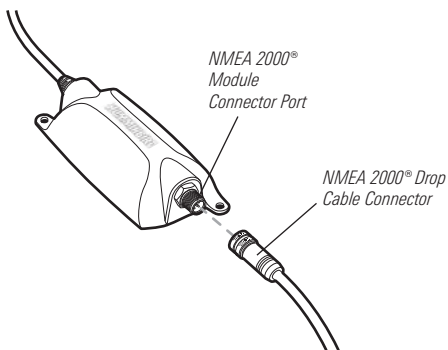

### **4. Connect the Ethernet Switch Power Cable to Power**

---

See your Ethernet Switch installation guide for instructions.

# Powering On

---

Follow the instructions below to power on your Humminbird® control head(s).

## To Power On:

1. Press the  POWER/LIGHT key.
2. When the Title screen is displayed, press the MENU key to access the Start-Up Options Menu.
3. Use the 4-WAY Cursor Control key to select Normal (if there is a transducer attached to the control head) or Simulator (if there isn't a transducer attached to the control head).
  - If a functioning transducer is connected, Normal operation will be selected automatically at power up, and your Fishfinder can be used on the water.
  - If a transducer is not connected and you wait too long to select a Start-Up Option, the system will default to whichever menu is already highlighted.
  - In Simulator you can learn how to use your control head and save settings in advance for later use.

**NOTE:** See your control head operations manual for more information about the Start-Up Options Menu.

**NOTE:** If you have an InterLink™ connected to the network, the NMEA 2000® will disable the InterLink™ because both network systems cannot be used at the same time.

## **System Setup**

---

Confirm all control heads and accessories on your NMEA 2000® network are powered on and operating. Proceed to the following sections to configure your control head(s) to recognize the connected equipment and sensors on the NMEA 2000® Network:

- **Selecting NMEA 2000® Data Sources**
- **Selecting NMEA 2000® GPS Sources**
- **Setting Alarms**
- **Displaying and Using NMEA 2000® Views**

## NMEA 2000® Data Sources Setup

---

When the NMEA 2000® Module is first installed and connected on the NMEA 2000® network, the control head(s) will automatically detect all connected NMEA 2000® sources (engines, tanks, depth sounders, etc.). The available sources are added to the Accessories menu tab, under NMEA2K Gateway.

*NOTE: NMEA 2000® menus and menu options are displayed as NMEA2K.*

- **Source Setup:** Use the NMEA2K Gateway menu to select the sources that will provide data for the digital readouts in the NMEA 2000® Views. The changes you make are saved even after the unit is powered off.

*NOTE: If there is only one source connected on the NMEA 2000® network, that source will be automatically selected.*

- **GPS Source Setup:** When you power on the network for the first time, the control head will automatically choose a connected or internal GPS receiver to provide data to the control head. To use a GPS receiver that is installed on the NMEA 2000® network, it must be manually selected from the Network Source Setup dialog box. See *NMEA 2000® GPS Source Setup* for more information.
- **Control Head(s):** The Sources and GPS Source have to be set up on each control head on the network.
- **Lost Data Source:** If the control head cannot detect the selected NMEA 2000® data source, the digital readout box will go blank in NMEA 2000® Views.
- **NMEA 2000® PGN Messages:** The NMEA 2000® PGNs are listed in the *Specifications* section of this manual.

NMEA2K Sources
Engine 1
Engine 2
Tank 1
Tank 2
Depth
Attitude
Heading
Trip Parameters
Air Temperature

NMEA2K Sources Menu

**NOTE:** If your control head does not have a CHECK/INFO key, press the top VIEW PRESET key .

## 1. Select NMEA 2000® Data Sources

1. **Main Menu:** Press the MENU key twice. Select the **Accessories** menu tab.

**NOTE:** In NMEA2K Views, press the MENU key once to open the Main Menu (see **Views**).

2. Select **NMEA2K Gateway**. Press the RIGHT Cursor key to open the **NMEA2K Sources** menu.
3. Press the DOWN or UP Cursor key to select a source group.
4. Press the RIGHT Cursor key to open the submenu for that source.
5. Press the DOWN or UP Cursor key to select a data source. Press the RIGHT Cursor key or CHECK/INFO key to select the data source.

6. Press the EXIT key to return to the NMEA2K Sources menu.
7. Repeat steps 3 - 6 to select another data source.
8. Repeat steps 1 - 7 for each control head on the network where you want to view NMEA 2000® data.

NMEA2K Sources Menu: Attitude Sources Submenu

Attitude	
AIRMAR, PB200 WeatherStation, SN2335526	<input checked="" type="radio"/>
MARETRON	<input type="radio"/>
None	<input type="radio"/>

Other available sources on the NMEA 2000® network.

Press the RIGHT Cursor key or the CHECK/INFO key to select a NMEA2K source.

**NOTE:** If a sensor is not detected during the configuration, confirm that the power source for the device is turned on, or check the installation and cable connection.

## 2. Set NMEA 2000® Data Offsets

---

Use the NMEA2K Data Offset menu option to adjust digital readouts by the amount you set. For example, use Depth Adjustment to adjust the digital depth readout to indicate depth from the waterline or the boat's keel.

### To Set a Data Offset:

1. **Main Menu:** Press the MENU key twice. Select the **Setup** menu tab.  
*NOTE: In NMEA2K Views, press the MENU key once to open the Main Menu (see Views).*
2. Select **NMEA2K Data Offset**. Press the RIGHT Cursor key to open the submenu.
3. Select a data option. (Depth Adjustment, Heading Adjustment, Temp (Water) Adjustment, STW Adjustment)
4. Press the LEFT and RIGHT Cursor keys to adjust the setting.
5. **Close:** Press the EXIT key.

## 3. Select Units of Measurement for NMEA 2000® Readouts

*(International models only)*

---

Use this section to set the system display preferences for your NMEA 2000® digital readouts.

*NOTE: The Setup menu tab includes various menu options to display units for depth, temperature, distance, and speed. See your control head operations manual for more information about setting display preferences.*

### To Select Units of Pressure:

1. **Main Menu:** Press the MENU key twice. Select the **Setup** menu tab.  
*NOTE: In NMEA2K Views, press the MENU key once to open the Main Menu (see Views).*
2. Select **Units - Pressure**.
3. Select a setting. (inHg/PSI, hPa/kPa)
4. **Close:** Press the EXIT key.



## To Select Units of Volume:

1. **Main Menu:** Press the MENU key twice. Select the **Setup** menu tab.

***NOTE:** In NMEA2K Views, press the MENU key once to open the Main Menu (see Views).*

2. Select **Units - Volume**.
3. Press the LEFT or RIGHT Cursor key to select a setting. (U.S. Gallons, Liters)
4. **Close:** Press the EXIT key.

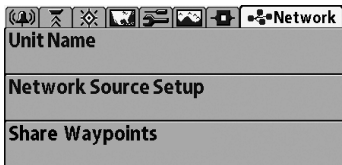

## Network Menu Tab

---

When a control head is connected to the NMEA 2000® Module, the Network menu tab is added to the Main Menu system.

The **Network** menu tab includes the following menu options:

- **Unit Name:** Displays the name of the control head. The default Unit Name is based on its model number and serial number. To change the Unit Name, see *Customize the Unit Name*.
- **Network Source Setup:** Opens the Network Source Setup dialog box. The Network Source Setup dialog box displays all sonar, temperature, and GPS sources detected on the network. The sources may be shared on the network or operating locally with their connected control head.

**NOTE:** *The Sonar and Temperature Sources in this dialog box are not NMEA 2000® sources. For NMEA 2000® network purposes, you will only need to open the Network Source Setup dialog box to select a NMEA 2000® GPS source. See **NMEA 2000® GPS Source Setup**.*

## Customize the Unit Name

Each control head is assigned a **Unit Name**, which is based on its model number and serial number. The unit name is also displayed next to a source name in the Network Source Setup dialog box so you can see where the source is connected.

When you're first setting up your network, you may want to change how the unit name is displayed, so it is easier to identify each unit on the network.

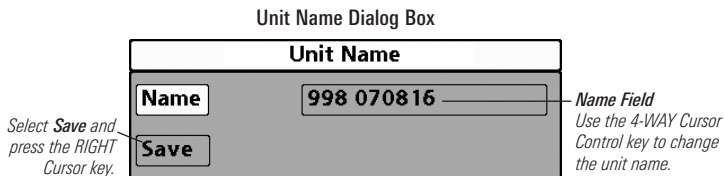

### To Customize the Unit Name:

1. **Main Menu:** Press the MENU key twice. Select the **Network** menu tab.

*NOTE: In NMEA2K Views, press the MENU key once to open the Main Menu (see Views).*

2. Select **Unit Name**. Press the RIGHT Cursor key. The unit name is displayed in the dialog box.
3. Use the 4-WAY Cursor Control key to select the Name field. You can change the control head display name as follows:

**Move within the Name Field:** Press the RIGHT or LEFT Cursor key.

**Change a Letter or Number:** Press the UP and DOWN Cursor keys. All upper and lower case letters are available (including digits 0-9 and some punctuation characters).

4. **Save:** Use the 4-WAY Cursor Control key to choose Save, and then press the RIGHT Cursor key.
5. Repeat steps 1 - 4 for each control head on the network.

# NMEA 2000® GPS Source Setup

---

When you power on the control head for the first time, it will automatically choose the connected or internal GPS receiver to provide data to the control head. **To use a NMEA 2000® GPS source connected on your NMEA 2000® network**, the source must be manually selected from the Network Source Setup dialog box.

- **Digital Readouts:** To provide digital readout data for NMEA2K views, select a NMEA 2000® GPS Source.
- **Humminbird® Views:** The NMEA 2000® GPS source will display data in Sonar Views, Chart Views, Bird's Eye View, etc. It is the only NMEA 2000® source that can display data outside NMEA2K views.
- **Multiple Control Heads:** If you have more than one unit connected via Ethernet Switch, you must select the NMEA 2000® GPS on each control head.
- **Menu System and Views:** When you select a NMEA 2000® GPS source, the menu settings, view rotation, and digital readouts will automatically update on the control head.

## 1. Select a NMEA 2000® GPS Source

---

Use the instructions below to select a NMEA 2000® GPS source for your control head.

### To Select a NMEA 2000® GPS Source:

1. **Main Menu:** Press the MENU key twice. Select the **Network** menu tab.

***NOTE:** In NMEA2K Views, press the MENU key once to open the Main Menu (see Views).*

2. Select **Network Source Setup**, and press the RIGHT Cursor key.
3. Press the RIGHT Cursor key until the GPS tab is selected.
4. **Scroll:** Press the DOWN or UP Cursor keys. The selected source is highlighted in white.

- Select:** Press the RIGHT Cursor key. The check mark indicates that the source is being used by the control head.
- Save:** Press the EXIT key twice to close the dialog box. Network settings are saved even after the unit is powered off.
- Repeat steps 1 - 6 for each control head on the network.

### Selecting a NMEA 2000® GPS Source

Network Source Setup					
Status	Sonar	T1	T2	T3	GPS
Name	Model	Type	Fix		
1580385	MARETRON, GP	NMEA2K	Fix	<input type="checkbox"/>	<i>Selected</i> The check mark indicates the source is used by the control head.  <i>Empty</i> The empty box indicates the GPS data is available but not selected.
2335526	AIRMAR, PB20	NMEA2K	Fix	<input type="checkbox"/>	
2409934	AIRMAR, G218	NMEA2K	Fix	<input checked="" type="checkbox"/>	
1580526	M1198c SI	Ext	Fix	<input type="checkbox"/>	

The control head detects all of the GPS sources in the network.

*GPS tab*

*Unit Name Column (see Customize the Unit Name)*

*Unit Model Number Column*

*GPS Type Column (Internal, External, or NMEA2K)*

*GPS Fix Column*

**NOTE:** The current GPS Fix Type is reported as No Fix, Fixed, or Enhanced. An Enhanced fix has been augmented using information from WAAS, EGNOS, or MSAS.

## Confirm and Change a Lost NMEA 2000® GPS Source

---

- **NMEA2K Views:** If the control head cannot detect the set NMEA 2000® GPS receiver, the digital readout boxes will go blank in NMEA2K Views. See *Select a NMEA 2000® GPS Source* to select another GPS receiver in the network.
- **Humminbird® Views (Sonar Views, Chart Views, etc):** If the control head cannot detect the set NMEA 2000® GPS receiver, it will automatically select another available GPS source. If no local GPS source is available, the digital readout boxes will flash. Open the Network Source Setup dialog box to check connections and select a new GPS source.

**NOTE:** To change a source after the network has been configured, open the Network Source Setup dialog box and change a GPS source at any time (see *NMEA 2000® GPS Source Setup*). Network settings are saved even after the unit is powered off.

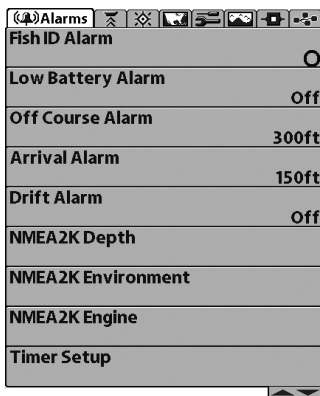

1100 Series™ Alarms Menu Tab

## Set Alarms

Alarms are based on the limits you set for a device such as battery voltage, depth, water temperature, and more. Installing and connecting the NMEA 2000® Module adds the following NMEA 2000® Alarms to the Alarms Menu tab:

- NMEA2K Depth
- NMEA2K Environment
- NMEA2K Engine

Each group expands into a submenu, which lists the alarms that fall under that group. See the *NMEA 2000® Alarms Table* at the end of this section for a complete list of NMEA 2000® alarms.

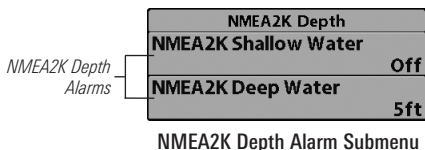

### 1. Set NMEA2K Alarms

1. **Main Menu:** Press the MENU key twice. Select the **Alarms** menu tab.

*NOTE: In NMEA2K Views, press the MENU key once to open the Main Menu (see Views).*

2. Select a NMEA2K alarm group. (NMEA2K Depth, NMEA2K Environment, NMEA2K Engine)
3. Press the RIGHT Cursor key to open the submenu.
4. Press DOWN or UP Cursor key to select an alarm.
5. Press the RIGHT or LEFT Cursor Key to adjust the alarm setting.
6. **Close:** Press the EXIT key to return to the Alarms menu.

7. Repeat steps 2 - 6 to set another alarm.

**NOTE:** See your control head operations manual for full alarms menu settings.

**NOTE:** When an alarm is triggered, you can silence it by pressing any key. The alarm will be silenced, and will not be triggered again until a new instance of the alarm condition is detected.

## Confirm an Alarm

When an alarm is triggered in the system, an alert will display on-screen. To acknowledge the alarm, press any key on the control head.

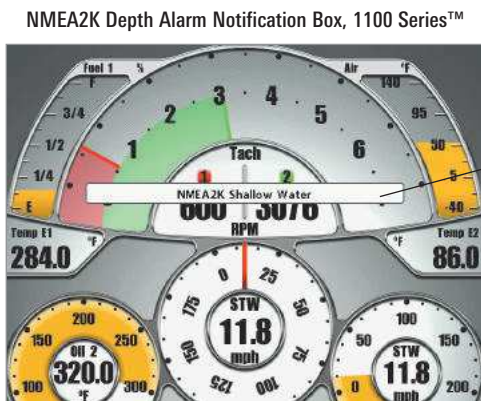

The name of the alarm triggered appears on the screen. Press any key to confirm and silence the alarm.



## NMEA 2000® Alarms Table

Menu	Alarm Name	Range
<b>NMEA2K Depth</b>	NMEA2K Shallow Water	Off, 1 – 330 feet, 0.5 – 100.0 meters*, or 0.1 – 55 fathoms; Default = Off
	NMEA2K Deep Water	Off, 1 – 330 feet, 0.5 – 100.0 meters*, or 0.1 – 55 fathoms; Default = Off
<b>NMEA2K Environment</b>	NMEA2K Temperature (Air)	Off, - 40°F – +140° F or - 40°C – + 60° C*; Default = Off
	NMEA2K Temperature (Water)	Off, 33°F – 120°F or 1°C – 50°C*; Default = Off
<b>NMEA2K Engine</b>	Total Fuel	Off, 1% – 100%; Default = Off
	Check Engine	Off, On; Default = Off
	Engine Over Temperature	Off, On; Default = Off
	Engine Low Oil Pressure	Off, On; Default = Off
	Engine Low Oil Level	Off, On; Default = Off
	Engine Low Fuel Pressure	Off, On; Default = Off
	Engine Low System Voltage	Off, On; Default = Off
	Engine Low Coolant Level	Off, On; Default = Off
	Engine Water Flow	Off, On; Default = Off
	Engine Charge Indicator	Off, On; Default = Off

\* International models only.

## Views

---

When the NMEA 2000® Module is connected to your Humminbird® control head, new views and menus will be added to the control head.

- **NMEA2K Views** are added to the views rotation and the Views menu tab.
- **Views X-Press™ Menu** will become available, allowing you to easily access all views. See **Views X-Press™ Menu** for more information.
- **Digital Readouts** on the NMEA2K views can be customized.

***NOTE:** In NMEA2K Views, press the MENU key once to open the Main Menu.*

## NMEA2K Data Box View

NMEA2K Data Box View presents a full screen view of digital data boxes. It automatically displays a default data set, and you can also select a data readout for each data box. See *Select Readouts for NMEA2K Views* for more information.

*NOTE: The view must be displayed on the screen in order to change the digital readouts. The availability of the digital readout information varies by model.*

700 Series™ HD Data Box View

Temp E1 °F <b>1</b> <b>181.7</b>	Temp E2 °F <b>2</b> <b>180.3</b>
SOG MPH <b>3</b> <b>25.4</b>	NMEA2K Depth ft <b>4</b> <b>17.9</b>
COG °T <b>5</b> <b>292.7</b>	Hdg °T <b>6</b> <b>291.2</b>

- 1** Engine 1 Temperature
- 2** Engine 2 Temperature
- 3** Speed Over Ground (SOG)

- NMEA2K Depth **4**
- Course Over Ground (COG) **5**
- Heading (Hdg) **6**

## NMEA2K Gauge View

NMEA2K Gauge View presents a full screen view of gauges and data boxes. It automatically displays a default data set, and you can select the data readouts for the gauges and data boxes. See *Select Readouts for NMEA2K Views* for information.

*NOTE: The view must be displayed on the screen in order to change the digital readouts. The availability of the digital readout information varies by model.*

- Gauges display data both graphically and numerically.

800/900 Series™ Gauge View

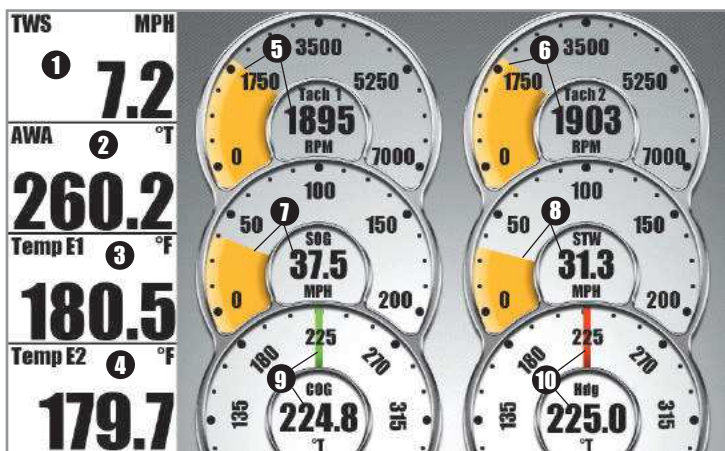

- ① True Wind Speed (TWS)
- ② Apparent Wind Angle (AWA)
- ③ Engine 1 Temperature
- ④ Engine 2 Temperature
- ⑤ Engine 1 Tachometer (Gauge & Digital Readouts)
- ⑥ Engine 2 Tachometer (Gauge & Digital Readouts)
- ⑦ Speed Over Ground (SOG) (Gauge & Digital Readouts)
- ⑧ Speed Through Water (STW) (Gauge & Digital Readouts)
- ⑨ Course Over Ground (COG) (Gauge & Digital Readouts)
- ⑩ Heading (Hdg) (Gauge & Digital Readouts)

## NMEA2K One Engine View

NMEA2K One Engine View presents a full screen view of gauges, which allows you to monitor fuel level, engine temperature, and RPMs from one engine connected on your NMEA 2000® network. The RPM readout is fixed in this view, and you can select the data readouts for the other gauges. See *Select Readouts for NMEA2K Views* for more information.

**NOTE:** The view must be displayed on the screen in order to change the digital readouts. The availability of the digital readout information varies by model.

- **Engine Tachometer (Tach)** is a fixed gauge on the view.
- A **Check Engine (Service) Icon** will display in the Engine Tachometer readout when engine conditions require attention (See *1100 Series™ Double Engine Monitoring View*).

1100 Series™ Single Engine Monitoring View



- |  |  |   |
|--|--|---|
| 1 Engine 1 Tachometer (Gauge & Digital Readouts [fixed]) | Water Temperature                                  | 5 |
| 2 Engine 1 Fuel Tank Level                               | Speed Over Ground (SOG) (Gauge & Digital Readouts) | 6 |
| 3 Engine 1 Temperature                                   | Heading (Hdg) (Gauge & Digital Readouts)           | 7 |
| 4 Air Temperature  | Engine 1 Fuel Rate (Gauge & Digital Readouts)      | 8 |

## NMEA2K Two Engine View

**NMEA2K Two Engine View** presents a full screen view of gauges, which allows you to monitor fuel level, engine temperature, and RPMs from two engines connected on your NMEA 2000® network. The RPM readout is fixed in this view, and you can select the data readouts for the other gauges. See *Select Readouts for NMEA2K Views* for information.

*NOTE: The view must be displayed on the screen in order to change the digital readouts. The availability of the digital readout information varies by model.*

- **Engine Tachometer (Tach)** is a fixed gauge on the view.
- A **Check Engine (Service) Icon** will display in the Engine Tachometer readout when engine conditions require attention (See *1100 Series™ Double Engine Monitoring View*).

1100 Series™ Double Engine Monitoring View



① Engine 1 Tachometer (fixed)

② Engine 2 Tachometer (fixed)

③ Engine 1 Fuel Tank Level

④ Engine 2 Fuel Tank Level

⑤ Engine 1 Temperature

Engine 2 Temperature ⑥

Speed Over Ground (SOG) (Gauge & Digital Readouts) ⑦

Heading (Hdg) (Gauge & Digital Readouts) ⑧

Engine 1 Fuel Rate (Gauge & Digital Readouts) ⑨

Check Engine (Service) Icon ⑩

# Display NMEA2K Views

Display NMEA2K Views using the following methods:

- **Cycle:** When you press the VIEW key repeatedly, the display cycles through the available views on your screen. When you press the EXIT key, the display cycles through the available views in reverse order.
- **Views X-Press™ Menu:** Press and hold the VIEW key. The Views X-Press™ Menu organizes all available views into groups so that you can display a view quickly.



Views X-Press™  
Menu

## Display a View On-Screen Using the Views X-Press™ Menu

The **Views X-Press™ Menu** provides a shortcut to all available views so you can find and display a view quickly.

### To Display a View Using the Views X-Press™ Menu:

1. Press and hold the VIEW key until the **Views X-Press™ Menu** displays on the screen.
2. Press the DOWN or UP Cursor key to select a group (Sonar, Chart, Radar, Data, System), and press the RIGHT Cursor key.
3. Select a View, and press the RIGHT Cursor key or the CHECK/INFO key to display that view.

**NOTE:** If your control head does not have a CHECK/INFO key, press the top VIEW PRESET key .

Select a View and press the RIGHT Cursor key or the CHECK/INFO key to immediately display that view.

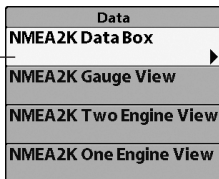

Views X-Press™ Menu: Data Views Submenu

**NOTE:** When a view is selected and displayed through the Views X-Press™ Menu, that view will automatically be set to "Visible" under the Views menu tab.

## Select Readouts for NMEA2K Views

---

Installing and connecting a NMEA 2000® Module adds additional data sets to the Select Readouts menu. To customize data items displayed within each NMEA2K view, see the instructions below.

***NOTE:** To customize the digital readouts in a NMEA2K view, the view must be displayed on the screen when you open the Select Readouts menu. The availability of the digital readout information varies by model.*

### To Select Readouts:

1. **Main Menu:** Press the MENU key once. Select the **Setup** menu tab.
2. Press the UP or DOWN Cursor key to select **Select Readouts**. Press the RIGHT Cursor key to open the Select Readouts submenu.

***NOTE:** If the Select Readouts menu option does not appear under the Setup Menu tab, change the User Mode to Advanced.*

3. Press the UP or DOWN Cursor key to select a Readout position, then press the RIGHT or LEFT Cursor key to select a data subgroup.
4. Press the CHECK/INFO key to open the submenu for that data group.

***NOTE:** If your control head does not have a CHECK/INFO key, press the top VIEW PRESET key .*

5. Press the UP or DOWN Cursor key to select a data option, and press the RIGHT Cursor key or the CHECK/INFO key to display that data in the readout position.

***NOTE:** If your control head does not have a CHECK/INFO key, press the top VIEW PRESET key .*

***NOTE:** The selected readout will immediately display on the screen.*

6. Press the EXIT key to return to the Select Readouts menu.

***NOTE:** See your control head operations manual for more information about selecting readouts.*

***NOTE:** Certain NMEA2K Views have fixed digital readouts that cannot be customized. See **Views** for more information.*



### Selecting a Readout Position, 1100 Series™ Gauge View

Select a Readout Position. Use the LEFT or RIGHT Cursor key to select a data group.

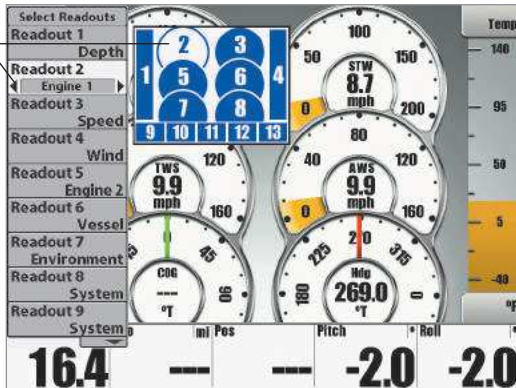

### Selecting Data for the Readout Position, 1100 Series™ Gauge View

Engine 1 Submenu

Select a Data Option and press the RIGHT Cursor key or the CHECK/INFO key to select.

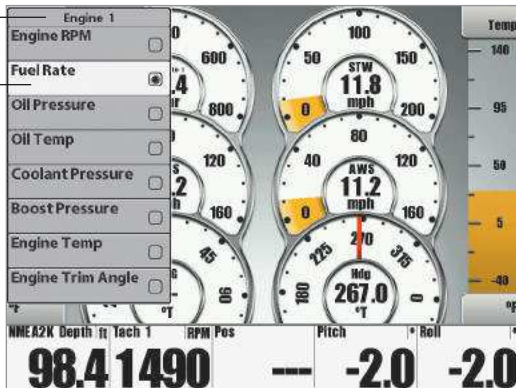

# Troubleshooting

---

Before contacting the Humminbird® Customer Resource Center, please read the following section. Taking the time to review these troubleshooting guidelines may allow you to solve a performance problem yourself, and therefore avoid sending your unit back for repair.

## Fishing System Doesn't Power Up

---

If your Fishing System doesn't power up, use the installation guide that is included with your Fishing System to confirm specific details, making sure that:

- the power cable is properly connected to the Fishing System control head,
- the power cable is wired correctly, with red to positive battery terminal and black to negative terminal or ground,
- the fuse is operational,
- the battery voltage of the power connector is at least 10 Volts, and

Correct any known problems, including removing corrosion from the battery terminals or wiring, or actually replacing the battery if necessary.

## Fishing System Defaults to Simulator with a Transducer Attached

---

A connected and functioning transducer will cause the newly-started Fishing System to go into Normal operating mode automatically. If, when you power up the Fishing System, it goes into Simulator mode automatically, even though a transducer is already connected, this means that the control head is not detecting the transducer. Perform the following troubleshooting tasks:

- Using the Installation Guide that also comes with your Fishing System, check to make sure that the transducer cable is securely connected to the Fishing System. Reconnect if necessary, and power up the Fishing System again to see if this fixes the problem.
- Replace the non-functioning transducer with a known good transducer if available and power up the control head again.
- Check the transducer cable. Replace the transducer if the cable is damaged or corroded.

# Specifications

## NMEA 2000® Sentences Table:

Message (PGN)	Description	Input	Output
059392	ISO Acknowledgement	•	•
059904	ISO Request	•	•
060928	ISO Address Claim	•	•
126208	NMEA - Request Group Function	•	•
126464	Receive/Transmit PGN's Group Function	•	•
126992	System Time	•	
126996	Product Information	•	•
127250	Vessel Heading	•	
127251	Rate of Turn	•	
127257	Attitude	•	
127258	Magnetic Variation	•	
127488	Engine Parameters, Rapid Update	•	
127489	Engine Parameters, Dynamic	•	
127505	Fluid Level	•	
128267	Water Depth	•	
128275	Distance Log	•	
129026	COG & SOG, Rapid Update	•	
129029	GNSS Position Data	•	
129033	Time & Date	•	
129539	GNSS DOPs	•	
129540	GNSS Sats in View	•	
130306	Wind Data	•	
130310	Environmental Parameters	•	
130311	Environmental Parameters	•	
130312	Temperature	•	
130313	Humidity	•	
130314	Actual Pressure	•	

# NMEA 2000® Module Configurations

Only one Humminbird® NMEA 2000® Module can be connected to a single NMEA 2000® network at one time, as shown in the graphics below.

## Supported Configuration Example 1

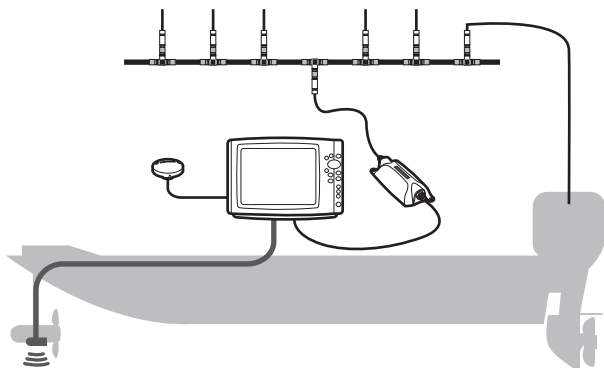

*Single Control Head Configuration - Connect the NMEA 2000® Module to one NMEA 2000® network and one Humminbird® control head.*

## Supported Configuration Example 2

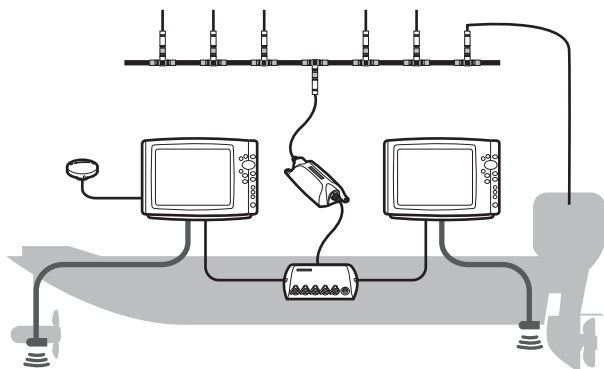

*Multiple Control Head Configuration Using One Ethernet Switch - Connect the NMEA 2000® Module to one NMEA 2000® network and one Humminbird® Ethernet Switch. Up to four Humminbird® control heads can be connected to the Ethernet Switch.*

Humminbird® does not support the following configurations:

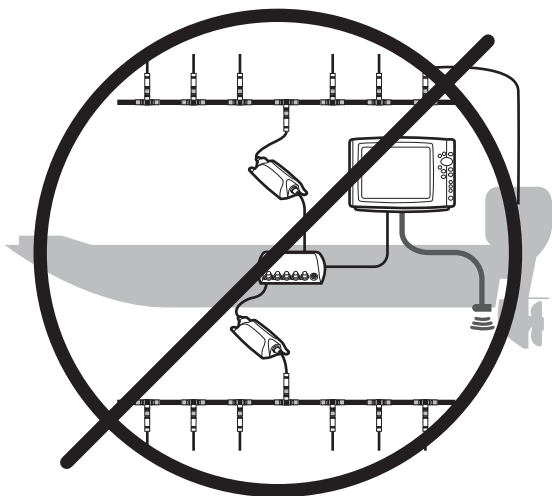

*Do not connect two NMEA 2000® Modules to one Humminbird® Ethernet Switch.*

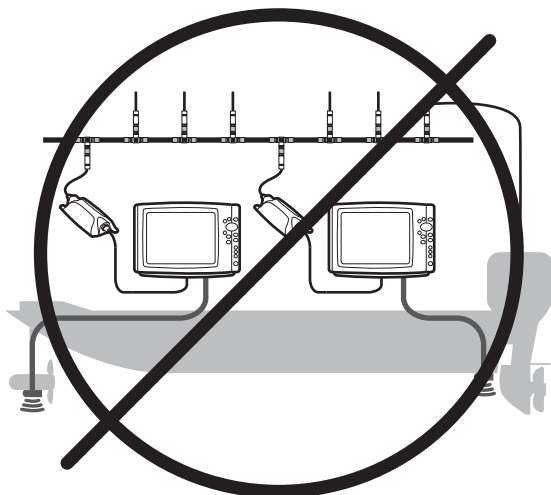

*Do not connect two NMEA 2000® Modules to one NMEA 2000® network.*

## **Contact Humminbird**

---

Contact Humminbird Customer Service in any of the following ways:

**Web site:**

[humminbird.com](http://humminbird.com)

**E-mail:**

[service@humminbird.com](mailto:service@humminbird.com)

**Telephone:**

1-800-633-1468

**Direct Shipping:**

Humminbird  
Service Department  
678 Humminbird Lane  
Eufaula, AL 36027 USA

**Hours of Operation:**

Monday - Friday

8:00 a.m. to 4:30 p.m. (Central Standard Time)

